

Embedded FPGA and DSP Computing 2010

Unitronix supplies Australia's widest range of FPGA, DSP embedded computing cards and black box systems, covering the whole applications market for high end embedded FPGA and signal processing solutions. Cards on PMC, XMC, VME, VXS, VPX 3U and 6U, "Ether to Ethernet" black box solutions, and specialised development software for FPGA Systems utilised in embedded applications. We have a 20 year history of providing embedded image and signal processing solutions to Australian application developers. As such Unitronix can be relied upon to provide knowledgeable support to design engineers looking into signal processing applications. After all it's not easy designing embedded systems full stop, it's definitely more tricky with signal processing solutions and when this all needs to be ruggedized and miniaturised into a field deployable solution then you really need to be talking to us. Unitronix can help with data flow architectures, computational element resource management, wider systems architecture and data structures. In addition and as an example, Curtis Wright (one of our suppliers), have the worlds most comprehensive and easy to use resource/ systems management software tools that will be of huge utility to engineers when developing a larger signal array and processing capability. For more details on these products please contact UNITRONIX on (02) 49773511, or email sales@unitronix.com.au.

VME – VPX Based Solutions:



Curtis Wright CHAMP-AV6 Four Dual Core PPC8640D CPUs:

Eight (8) CPUs!

The CHAMP-AV6 utilizes the VPX-REDI format to unleash the tremendous I/O bandwidth of its eight FreeScale PowerPC 8640 processor cores (Four 8640D dual-core processors). The local and off-board Serial RapidIO interfaces provide up to ten times the communications bandwidth that was achievable with the VME format. Signal processing applications with streaming data flows will benefit greatly from the dual 64-bit DDR2 memory subsystem associated with each 8640.



Curtis Wright CHAMP-AV5 Two Intel Dual Core i7s at 2.53GHz:

INTEL AS DSP!

The CHAMP-AV5 multi-processing board brings the floating-point performance of the Intel® Core i7™ architecture to VME64x form factor standard. Utilizing a pair of 2.53GHz dual-core Core i7 processors, the CHAMP-AV5 delivers up to 81 GFLOPs of performance. The 17GB/s (peak) DDR3 memory sub-system supports applications with high memory utilization and streaming data I/O.



Curtis Wright CHAMP FX2 Hybrid processor, Dual Xilinx V5s with MPC8641D:

Heteroginious Architecture!

The CHAMP-FX2 is Curtiss-Wright's next-generation FPGA-based computing platform. Utilizing a 6U VPX-REDI form factor, the CHAMP-FX2 harnesses the tremendous computing power of two Xilinx Virtex™-5 FPGAs, combined with the high-performance floating-point capabilities of the Freescale 8641D dual-core PowerPC™ processor and the exceptional performance and flexibility of a Serial RapidIO switching fabric to deliver unprecedented computational densities

Also available from Unitronix, SBCs and chassis for the VME –VPX to build full systems.

VXS RF Digitisers with Three (3) Large FPGA resources on board:

TEKMICRO High Speed Digitisers:

Virtex 6 available Q3

The Tekmicro QuiXilica V5 Architecture meets the needs of demanding sensor-processing applications across a range of environments. The QuiXilica V5 architecture uses the latest field programmable gate array (FPGA), Virtex5 based processors from Xilinx, advanced DDR3 SDRAM, and the latest communications technologies available. The triple FPGA architecture implemented on each card has been designed for optimum processing of digitised RF signals. There are seven cards in the QuiXilica range,

1. Titan V5 1.0 GSPS 4 Channel ADC @ 12bits, and 1.2 GSPS 4 Channel DAC @ 14bits.
2. Triton V5 2.2 GSPS ADC @ 10 bits and 3.0GSPS DAC @ 12 bits
3. Tarvos V5 185 MSPS 6 Channels ADC @ 16 bits and 1 Channel DAC @ 16 bits
4. Charon V5 1.2 GSPS 8 Channel DAC @ 12bits.
5. Atlas V5 1.0 GSPS ADC 8 Channels @ 12 bits
6. Orion V5 3.0 GSPS ADC 2 Channels @ 12 bits
7. Neptune V5 2.2 GSPS 2 Channel ADC @ 10 bits

Xilinx Virtex-5 FPGAs are the heart of the the Tekmicro V5 cards. The FPGAs interface between the digitiser chips, memory and I/O resources to provide a platform for implementing high performance real time processing. The V5 cards are configured with two SX95T FPGAs numbered 2 and 0 and one LX110T FPGA (optional LX220T, SX240T, or FX100T) numbered FPGA 1. All FPGAs are interconnected by wide parallel LVDS buses and also via high speed serial links using the Xilinx Rocket IO MGTs.

Two SFP+ sites and one QSFP site are provided on the front panel which utilize standard fiber optic or 1000BaseT modules providing physical layer support for standard protocols such as Gigabit Ethernet, Serial FPD (ANSI VITA 17.1 & 17.2), and Fibre Channel.

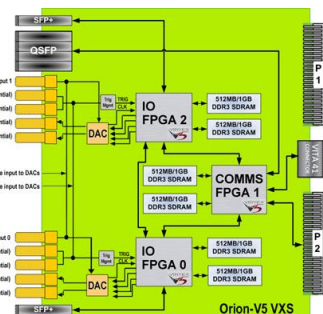

Also available from Unitronix, SBCs and chassis for VXS to build complete systems.

AMC Advanced Mezzanine Card Solution:



Available as Demo System
From Unitronix 2010

Bittware FPGA-computing Advanced Mezzanine Card with ALTERA Stratix IV GX FPGA with FMC site:
Based on Altera's Stratix IV GX FPGA, BittWare's S4-AMC (S4AM) is a mid-size, single wide AdvancedMC that can be attached to AdvancedTCA (Advanced Telecom Compute Architecture) carriers or other cards equipped with AMC bays, and used in MicroTCA systems. The S4AM features a high-density, low-power Altera Stratix IV GX FPGA designed specifically for serial I/O-based applications, creating a completely flexible, reconfigurable AMC. BittWare's ATLANTiS FrameWork, in conjunction with the FINE Host/Control Bridge, greatly simplifies application development and integration of this powerful board.

Also available from Unitronix, CPUs Intel and PPC , Ethernet, Video, and chassis to build AMC form factor systems.

FMC, VITA57 FPGA Mezzanine Card Solutions:



Curtis Wright range of VITA 57 FMC FPGA Mezzanien Cards:

ADC 510 Dual Channel Analogue input FMC module, TI ADS5463, 12bit @ 500MSPS
ADC 511 Dual Channel Analogue input FMC module, TI ADS5474, 14bit @ 400MSPS
ADC 512 Dual Channel Analogue input FMC module, National ADC083000, 8bit @ 3GSPS
ADC 513 Dual Channel Analogue input FMC module, National ADC08D1520, 8bit @ 1.5GSPS

DAC modules coming in 2010.



PMC – XMC and 3U VPX Based Solutions:



Curtis Wright XMC 442, Virtex 5 FPGA:

The XMC-FPGA05D is a high density I/O PMC/XMC module, supported by a user programmable Virtex-5 FPGA. The board may be used as a PMC with a 64-bit, 133MHz PCI-X interface to the host or as an XMC module supporting a x8 PCI Express interface to the host.



TEKMICRO Jazz Fibre SFPDP PMC:

The JazzFiber-V5™ Serial FPDP I/O Module provides a high speed connection between one or more external sensors and a processing or recording system using an open standard modular I/O architecture. Each JazzFiber-V5 module supports four fibre optic interfaces, which can be used as separate Serial FPDP channels or aggregated into logical streams using the channel bonding capability of the emerging VITA 17.2 standard. Additional VITA 17.2 features include enhanced protocol and higher bit rates.



Curtis Wright FPGA-05D PMC/ XMC, Virtex5 FPGA, ADC, DAC, LVDS input modules available:

The XMC-FPGA05D is a high density I/O PMC/XMC module, supported by a user programmable Virtex-5 FPGA. The board may be used as a PMC with a 64-bit, 133MHz PCI-X interface to the host or as an XMC module supporting a x8 PCI Express interface to the host.

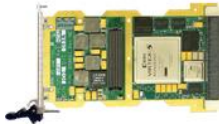

Curtis Wright FPE320 VPX 3U Virtex 5 FPGA with FMC site:

The FPE320 is a 3U VPX FPGA processor board that incorporates the largest Xilinx Virtex-5 FPGAs available with an FMC mezzanine site. It provides a large amount of resources in a small, rugged form factor. The FPE320 is the ideal FPGA platform for 3U systems that need to acquire analogue and other high-speed I/O or need a large FPGA processor.

D-TA Ether to Ethernet 10 Gigabit Sensor Processing:

D-TA Systems Inc. was established in 2007 with a mandate to simplify high-end Sensor Processing system development for Sonar, Radar, Communications, Signal Intelligence and Test and Measurement markets. Leveraging the latest technologies and many decades of experience in designing acoustic and radio systems, D-TA Systems has developed a complete slate of sensor Interface and processing solutions that drastically cut deployment time and cost.



**Tuneable RF to 6 GHz
Precision Analogue Signal Conditioning
High Speed Data Conversion
FPGA based DSP
Super high Speed Gateways to connect
sensors to computer.**

**For further information on these products or for technical support call:
UNITRONIX Pty Ltd**

Newcastle: Phone (02) 4977 3511 Fax (02) 4977 3522
Perth: Phone (08) 9455 2424 Fax (08) 9455 2458
unitsyd@unitronix.com.au - www.unitronix.com.au

