

UNITRONIX Pty Ltd

PO Box 486, Morisset NSW 2264
NSW: Tel: 61 2 4977 3511 Fax: 61 2 4977 3522
WA: Tel: 61 8 9455 2424 Fax: 61 8 9455 2458
unitsyd@unitronix.com.au www.unitronix.com.au

data sheet

AMC825-4

**PMC Module with four CAN bus
Nodes ARINC825 compliant for
Testing & Simulation of Avionic
CAN bus Systems**



www.aim-online.com



Right on Target

Avionics Databus Solutions

General Features

The AMC825-4 PCI Mezzanine Card (PMC) can work either with full functionality as an active CAN node for testing and simulating or in 'listening only' mode for monitoring and recording purposes of Avionic CAN bus (ARINC825) applications on up to four electrically isolated CAN bus nodes concurrently. All nodes are in conformance with the ISO11898-1/-2 standard. They are accessible by software separately and can be used as four independent CAN bus nodes.

An onboard IRIG-B time decoder allows users to accurately synchronise single or multiple modules to a common time source.

All supported signals are available through Front-I/O and Rear-I/O interface.

The AMC825-4 module consists of FPGA based CAN Interface Controllers as well as a FPGA based 32-bit Microcontroller Core and a separate processor for IRIG-B synchronisation with high resolution time stamping. All nodes are operating concurrently at CAN bus high speed bit rate

of up to 1Mbit/s with the intelligence to process scheduling of CAN frames in real time onboard to significantly off-load the host processor.

Supported options for all versions of AMC825 cards include:

- Rear-I/O
- Conduction Cooling/ Conformal Coating for Embedded Applications
- Extended Temperature Range (on request)

The AMC825-4 module operates also with the new PBA.pro™ Databus Test & Analysis Tool for Windows and Linux.



AMC825-4 Block Diagram

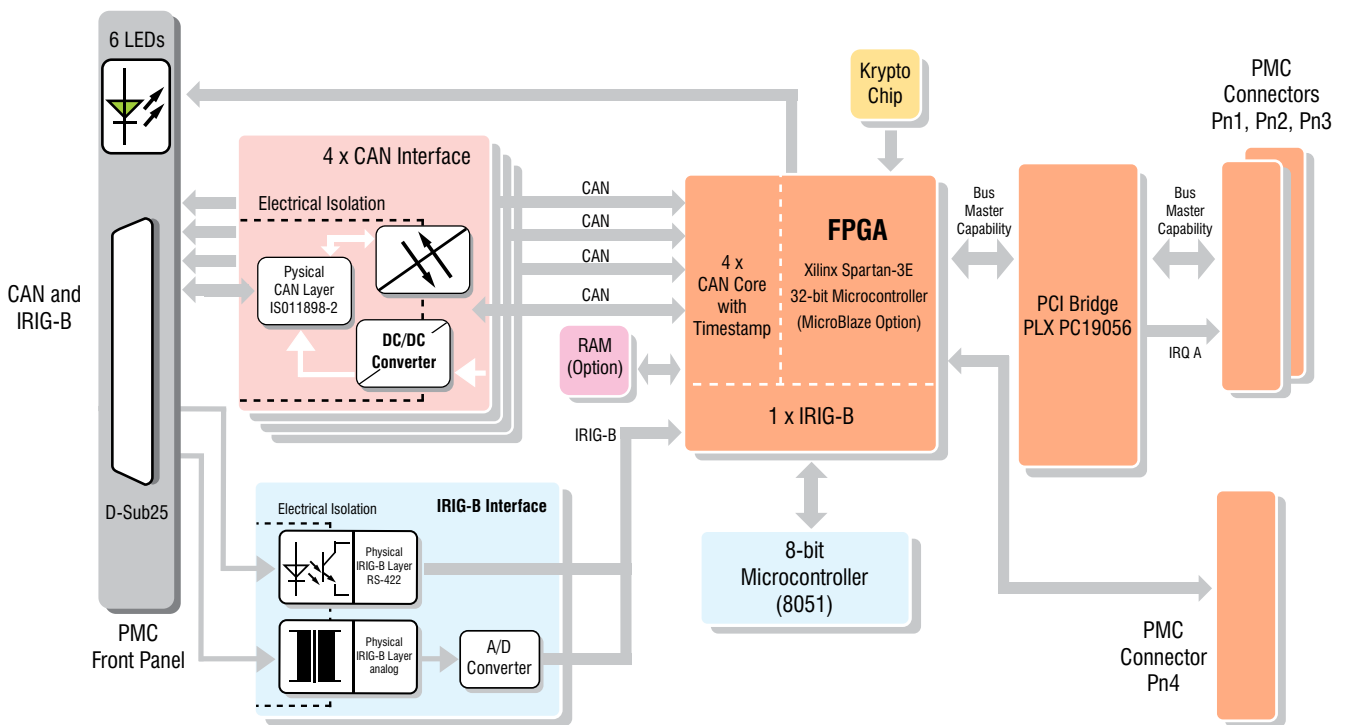

CAN bus Channel Operation

The AMC825-4 module provides real time simulation of up to four CAN bus nodes concurrently via FPGA based CAN control engine with an additional 32-bit Microcontroller. Each CAN bus operation speed is programmable in the range from 10kbit/s up to 1Mbit/s in accordance with the CAN 2.0B specification. Automatic baud rate detection is available. The AMC825-4 supports the 11-bit and 29-bit message ID operation in ID oriented (Object) mode. A Listening-Only mode is available for chronological monitoring (FIFO mode).

All basic CAN node functions are implemented in accordance with ISO11898, CAN 2.0 A/B.



Traffic Generation

AMC825-4 Transmitter operation allows users to fully program all relevant fields of the CAN bus message protocol including an 11-bit or 29-bit message identifier, RTR bit, data length code and up to eight user defined data bytes. Synchronisation of transmissions across multiple ports is supported.

- *Cyclic/ Acyclic ID Transmission Mode*
- *Programmable Inter Message Timing available*
- *Single Shot or Automatic Retry Function if arbitration lost*
- *Arbitration Lost Notification*
- *CAN bus compliant Error Handling*
- *Message and Error Counters*



Physical Bus Interface

The AMC825-4 cards have integrated CAN bus transceivers which are compliant with the ISO11898-2 high speed specification. The CAN bus interfaces are electrically isolated by default. All four ARINC825 nodes are available at the Front-I/O provided at one 25-way D-Sub (male) connector and at the Rear-I/O connector interface. The following signals are provided on both interfaces.

- *4 ARINC825 (CAN bus) Nodes (on Rear-I/O TTL level only)*
- *IRIG-B Input analogue and RS-422 compatible*

IRIG-B Time Decoder

AMC825-4 cards have an onboard IRIG-B time decoder with 1 μ s resolution and an automatic free wheeling detection. This allows synchronisation of multiple AMC825-4 cards to one common IRIG-B time source for the correlation of data across multiple ARINC825 CAN bus nodes.



Operation Modes

The AMC825-4 module provides different operation modes for all four CAN bus nodes.

The board basically supports two different operational modes, the Object and the FIFO mode.

In the Object mode each configured message ID has a separate buffer where message data and status information are stored in case of receiving IDs. In the Object mode, IDs can also be configured to be transmitted cyclically (scheduled transmission).

In the FIFO mode all or selected IDs are time stamped and stored in a FIFO in case of receiving IDs. The FIFO mode can be also used for transmitting IDs by passing the IDs to be sent to a transmit FIFO. In case of scheduled transmit operation the FIFO mode can be used in parallel e.g. to insert an acyclic transmission of IDs.

Independent from the selected modes above the board can be configured to operate in a Listening-Only mode which allows a passive monitoring of a CAN bus without disturbance of the existing traffic.

Furthermore automatic handling of CAN RTR-Frame is supported via an Auto-Answer mode.

- *Object and FIFO Transmit/ Receive modes supported*
- *CAN bus Listening-Only Mode for passive Monitoring*
- *Data Buffering with Real Time Data Updates*
- *Scheduled Transmission of IDs*
- *Acyclic Transmission of IDs*
- *ID oriented dependent Filtering*
- *Time Stamping of received frames with IRIG-B Time Code 1 μ s Resolution*
- *Auto-Answer mode for automatic RTR Frame Handling*
- *Physical Error Detection, Bit Error, CRC-/ Format Error, Bit Stuffing Error*
- *Event Generation*

Driver Software

The AMC825-4 modules are supplied with an Application Programming Interface (API) and Driver Software compatible with Windows, Linux and VxWorks.

Application Software

An ARINC825 Resource Component is available for AIM's PBA.pro™ Databus Test & Analysis Tool including Tx and Rx simulation capabilities, a chronological Bus Monitor and support for decoding of payload data within CAN messages. This allows to implement a powerful CAN bus/ ARINC825 Analyser or a complete Test System in conjunction with other AIM Avionics Databus Interfaces and PBA.pro™ supported 3rd party hardware.



AMC825-4

PMC Module with four CAN bus
Nodes ARINC825 compliant for
Testing & Simulation of Avionic
CAN bus Systems

AIM Office Contacts:

AIM GmbH

Sasbacher Str.2
79111 Freiburg
Germany
Tel: +49 761 45 22 90
Fax: +49 761 45 22 93 3
email: sales@aim-online.com

Vertriebsbüro München
Terofalstrasse 23 a
80689 München
Germany
Tel: +49 89 70 92 92 92
Fax: +49 89 70 92 92 94
email: salesgermany@aim-online.com

AIM UK

Cressex Enterprise Centre
Lincoln Road
High Wycombe
Bucks, HP12 3RB
UK
Tel: +44 1494 446844
Fax: +44 1494 449324
email: salesuk@aim-online.com

AIM-USA

Seven Neshaminy Interplex
Suite 211
Trevose
PA 19053
USA
Tel: 267-982-2600
Toll Free: 877-520-1553
Fax: 215-645-1580
email: salesusa@aim-online.com

Technical Data

System Interface:

32-bit; 33/66MHz +3,3V (+5V tolerant)
PCIbus (Rev. 2.2) compliant

Processors:

FPGA based 32-bit Microcontroller Core and 8051 Processor for IRIG-B handling

Memory:

64MB DRAM (optional)

Encoder/ Decoder:

FPGA based CAN bus Controller Core

Time Tagging:

46-bit absolute IRIG-B Time Code, 1 μ s resolution; free wheeling

Physical Bus Interface:

Up to 4x ISO11898-2 compliant high speed Transceivers. Each CAN bus Node is electrically isolated.
All signals are available at Front-I/O and at Rear-I/O Interface

Front-I/O Interface Connector

- One 25-way D-Sub (male) connector, providing four independent electrically isolated CAN bus nodes, and IRIG-B Time Code Input (analogue IRIG-B and RS422)

Rear-I/O Interface Connector

- 1x Standard PMC Connector Position Pn4.
Includes all signals which are available through Front-I/O Interface
Note: CAN bus is available at TTL level only

PMC/ PCI Interface Connector

- Pn1, Pn2 for PCI Bus Interface (Rev. 2.2) compliant
32-bit, 33/ 66MHz, +3,3V (+5V tolerant)

Dimensions: 149mm x 74mm, Standard PMC Format

Operating Temperature Range:

- Standard 0°C ... +50°C ambient
- Extended on request
- Storage Temp.: -40°C... +85°C ambient
- Conduction cooling available

Ordering Information

AMC825-4

4 CAN bus nodes ARINC825 on PCI Mezzanine Card (PMC module), Software programmable CAN bus nodes, IRIG-B Time Stamping

ACP825-4

ARINC825 to PCI Module comprising an AMC825-4 installed on an ACP-1, PCI Carrier Card

ACC825-3U-4

ARINC825 to cPCI Module (3U) comprising an AMC825-4 installed on an ACC-1, cPCI Carrier Card (3U)

ACC825-6U-X X= (4, 8)

ARINC825 to cPCI Module (6U) comprising one or two AMC825-4 cards installed on the ACC-2, cPCI Carrier Card (6U)

AVC825-X X= (4, 8)

ARINC825 to VME Module comprising one or two AMC825-4 cards installed on the AVC-2, VME Carrier Card

On Request:

Ready Made Adapter Cable (2.0 m): From 25-way D-Sub (male) connector to four 9-way D-Sub (male) connectors with CAN open compliant pin assignment and separate 9-way D-Sub (female) connector for IRIG-B input

General Features

The AVC-2 is a single slot, double height (6U) VME64x, extended VMEbus module with two separate PMC slots. The AVC-2 uses an on board, industry standard, Tundra chip (Universe II) providing the bridge between the VMEbus and PCIbus. The AVC-2 fulfils the requirements of the VME64x extension plus the Interface for Rear I/O. Each PMC-slot is in conformance with the Draft Standard Physical and Environmental Layers for PCI Mezzanine Cards (P1386.1/Draft 2.4).

Key features of the AVC-2 module:

- Easily configured with any combination of PMC modules
- Combine different interface types and functions on one VME card
- User configurable base address
- Front panel LED's for VMEbus/PCIbus activity/failure display
- Fully compliant to VME64x – extended VMEbus
- Hosts PMC modules designed to PMC standard P1386.1/Draft 2.4
- Driver Software Library for VxWorks and LynxOS available

AVC-2



VME Generic Carrier Card for PMC (PCIbus Mezzanine Card) modules

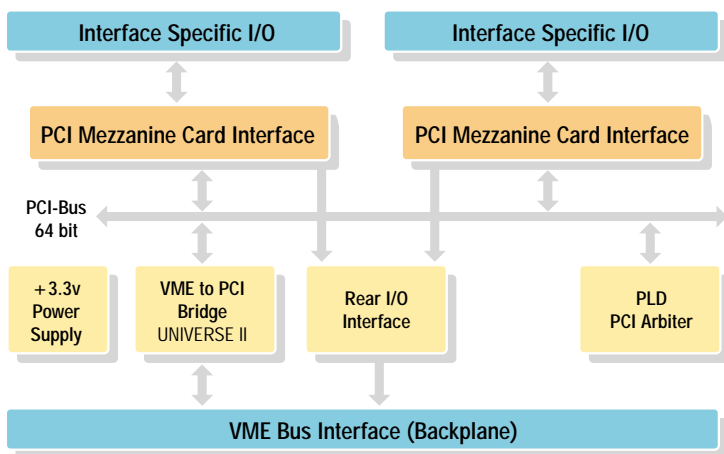

PMC Module Interface

The AVC-2 is designed to plug all standard PMC modules with a maximum PCIbus width of 64bit operating at 33MHz.

The AVC-2 carrier board supports the + 5.0V PCIbus signalling, hence only + 5.0V tolerant devices may be used. The use of a voltage keying pin protects against false PMC assembly.

Avionics Databus Solutions



AVC-2

VME Generic Carrier
Card for PMC (PCIbus
Mezzanine Card)
modules

AIM Office Contacts:

AIM GmbH

Sasbacher Str.2
79111 Freiburg
Germany
Tel: +49 761 45 22 90
Fax: +49 761 45 22 93 3
email: sales@aim-online.com

Vertriebsbüro München
Terofalstrasse 23 a
80689 München
Germany
Tel: +49 89 70 92 92 92
Fax: +49 89 70 92 92 94
email: salesgermany@aim-online.com

AIM UK

Cressex Enterprise Centre
Lincoln Road
High Wycombe
Bucks, HP12 3RB
UK
Tel: +44 1494 446844
Fax: +44 1494 449324
email: salesuk@aim-online.com

AIM-USA

Seven Neshaminy Interplex
Suite 211
Trevose
PA 19053
USA
Tel: 267-982-2600
Toll Free: 877-520-1553
Fax: 215-645-1580
email: salesusa@aim-online.com

Technical Data

VME to PCI Bridge: High performance 64bit VME interface
Fully compliant with PCI Standard (Revision 2.1)
VME master and slave capability
PCI master and slave capability
Integral FIFOs buffer multiple transactions in both directions
MBLT, BLT, ADOH, RMW and LOCK support
Programmable DMA controller with linked list support
Nine user programmable slave images on both busses
Four mailboxes and location monitor for message oriented systems
Eight semaphores
Full VMEbus system controller functionality
PCIbus burst size of 128 bytes
Supports coupled, posted and prefetched cycles on both busses
Provides clock speed of 33MHz with no wait states on PCIbus
Provides flexible mapping of hardware and software interrupts on both busses
Implemented using Industry leading VME to PCI Bridge device (TUNDRA UNIVERSE II).

PCIbus: Provides the connection between the PMC interfaces to the VMEbus Interface

Fully compliant to PCIbus Specification Rev 2.1
PCIbus width of 64 bit
PCIbus operation of 33MHz
Priority based PCIbus Arbiter

PMC Slot 1 + 2:

Each PMC slot provides 64bit, 33MHz PCIbus operation
Each PMC slot provides the capability for Rear-I/O (VME64x Mapping)

Front Panel: The Front panel provides two breakouts for using the standard PMC- front panel bezel

Front Panel LEDs: A System Indicator Array is located at the top end of the Front Panel for indicating assertion of the SYSFAIL line, the VMEbus activity, the PCIbus activity and PCIbus errors

Dimensions: Double Height (6U) Board (233 x 20mm x 160mm), Single-Width

Power Supply: +5VDC, 2 Watts typical without any PMC module installed

Weight: Approx. 230g without any PMC module installed

Temperature: 0 to +45°C Standard Operating
-15 to +60°C Extended Temperature
-40 to +85°C Storage

Humidity: 0 to 95% (non condensing)

Ordering Information

AVC-2

VME (6U) Carrier Module with two PMC slots

