



# PMC-FPGA05

## Xilinx® Virtex®-5 LX110 FPGA PMC Module

### UNITRONIX Pty Ltd

PO Box 486, Morisset NSW 2264

NSW: Tel: 61 2 4977 3511 Fax: 61 2 4977 3522

WA: Tel: 61 8 9455 2424 Fax: 61 8 9455 2458

unitsyd@unitronix.com.au www.unitronix.com.au



### Applications

- ◆ Electro Optics (EO)
- ◆ Electronic Warfare (EW)
- ◆ Telecommunications
- ◆ Surveillance
- ◆ Software Defined Radio (SDR)

### Features

- ◆ Xilinx Virtex-5 LX110 FPGA (user programmable)
- ◆ Multiple banks of SRAM for DSP
- ◆ Multiple banks of SDRAM for large buffers
- ◆ PCI-X interface
- ◆ Customizable digital I/O
- ◆ Windows®, VxWorks® and Linux® support

### Benefits

- ◆ I/O flexibility to process data from most any interface
- ◆ The latest generation Xilinx Virtex-5 FPGA for lower power and highest performance processing
- ◆ Optimized memory for fast data movement

### Overview

The PMC-FPGA05 is a Xilinx Virtex-5 LX110 FPGA based PMC module with high-speed, customizable data I/O and PCI-X interface to the host computer. The powerful FPGA is boosted by multiple banks of memory to ensure that processing capabilities of the PMC-FPGA05 is maximized.

The PMC-FPGA05 offers a variety of I/O modules that can be directly connected to the FPGA. These I/O modules include analog input, analog output, Camera Link, LVDS and RS485/422. Custom I/O modules may also be designed based on the specifications provided with the board.

### Xilinx Virtex-5 FPGA

The Virtex-5 XC5VLX110 FPGA is configured from FLASH. A default image which instantiates the PCI-X interface and FLASH programming interface is preloaded into the FLASH along with a recovery image which cannot be overwritten. There is space for 3 or more configurations and the image used is selected by switch.

### Digital I/O

There are 138 signals routed to a 180-way connector near the front panel. These lines are routed so that they may be used as single-ended signals or differential pairs. The FPGA I/O signals are banked, with two banks being used at the front panel connector. Each bank is independently configurable to 2.5V or 3.3V signaling. Developers can create custom modules suited to their application as we

Learn More

Web / [sales.cwembedded.com](http://sales.cwembedded.com)

Email / [sales@curtisswright.com](mailto:sales@curtisswright.com)

**CURTISS  
WRIGHT** Controls  
Embedded Computing

Innovation In Motion.  
[cwembedded.com](http://cwembedded.com)



supply complete specifications for these modules with the documentation that comes with the board. Another bank of 64 single-ended lines (32 differential pairs) connects to P14, the PMC user I/O connector, to support rear I/O.

### Memory

By default, three banks of 9Mbytes each QDR II SRAM support DSP functions in the Virtex-5 and are independently connected to the FPGA, providing great flexibility in how they are used. The SRAM is clocked at 200MHz, providing simultaneous read and write operations each at 800Mbytes/s. Two independent banks, each with 128Mbytes per second DDR2 SDRAM, are directly connected to the FPGA. Clocked at 200MHz, each bank can be used independently (e.g. filling one memory while emptying data from the other at 800Mbytes/s) or as a single 32-bit wide, 1600Mbytes/s memory structure. This memory provides a large pool of memory to buffer DMA transfers and other large data block operations.

### Flash

The Virtex-5 FPGA is configured from a 256Mbit (32Mbytes) on-board FLASH. A default configuration image, with a PCI-X interface and FLASH programming interface, is preloaded into the FLASH along with a recovery image. The FLASH is programmable through the PCI/PCI-X bus. Three or more Virtex-5 configurations can be held in the FLASH. The image used to configure the FPGA is selected by switch.

### Software

The PMC-FPGA05 is supported under the Windows XP, VxWorks and Linux. The BSP includes: VHDL library code blocks (demonstrating how board resources can be used), Windows XP drivers, API with C support libraries, Example code, FLASH programming and board debug utilities, Hardware and Software manuals. Development of VHDL code for the FPGA requires synthesis tools such as Xilinx ISE Foundation.

Table 1: Specifications

FPGA	
Type	Xilinx Virtex-5 LX110 (XC5VLX110)
Speed grade	-1, -2 or -3
Memory	
DDR2 SDRAM	2 x 64M x 16-bit
QDR2 SRAM	3 x 4M x 18-bit
FLASH	256Mb (FPGA boot/configuration including rescue image)
Input/Output	
Front Panel	138-way high-speed connector for customizable I/O modules
PCI Compliance	PCI 33MHz, PCI-X 66/100/133MHz, Master/slave/DMA, Interrupt support, Up to 1067Mbytes/sec
Software/HDL Code	
Toolschain	Xilinx ISE Foundation
Host Drivers	Windows 2000/XP, VxWorks, Linux
Utilities	FLASH programming, diagnostics
HDL Examples	Memory interfaces, PCI-X, I/O adaptor

Figure 1: PMC-FPGA05 Block Diagram

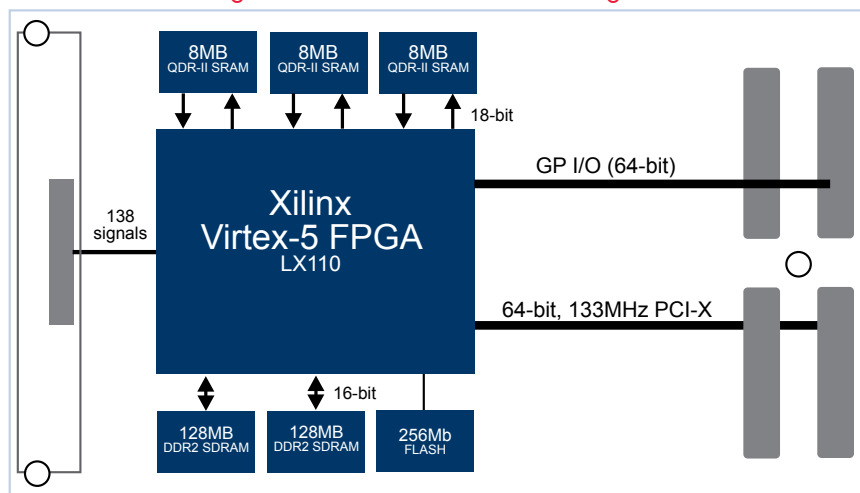



## **Warranty**

This product has a one year warranty.

## **Contact Information**

To find your appropriate sales representative, please visit:

Website: [www.cwembedded.com/sales](http://www.cwembedded.com/sales)

Email: [sales@cwembedded.com](mailto:sales@cwembedded.com)

For technical support, please visit:

Website: [www.cwembedded.com/support1](http://www.cwembedded.com/support1)

Email: [support1@cwembedded.com](mailto:support1@cwembedded.com)

The information in this document is subject to change without notice and should not be construed as a commitment by Curtiss-Wright Controls Inc., Embedded Computing (CWCEC) group. While reasonable precautions have been taken, CWCEC assumes no responsibility for any errors that may appear in this document. All products shown or mentioned are trademarks or registered trademarks of their respective owners.