



Data Sheet

**UNITRONIX Pty Ltd**  
 PO Box 486, Morisset NSW 2264  
 NSW: Tel: 61 2 4977 3511 Fax: 61 2 4977 3522  
 WA: Tel: 61 8 9455 2424 Fax: 61 8 9455 2458  
 unitysd@unitronix.com.au www.unitronix.com.au

# FPE320

## Xilinx® Virtex®-5 3U VPX Processor with FMC Site

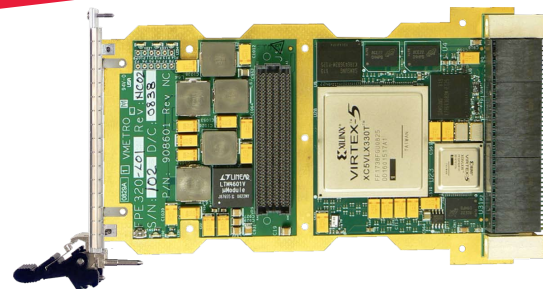

### Applications

- ◆ Electronic Warfare & Signal Intelligence (SIGINT)
- ◆ Electronic Counter Measures
- ◆ UAV Sensor Acquisition
- ◆ Semiconductor Inspection
- ◆ Seismic Imaging

### Features

- ◆ Supports Xilinx® Virtex®-5 SXT, LXT and FXT FPGAs
- ◆ FMC (VITA 57) mezzanine site for I/O
- ◆ DDR2 SDRAM and QDR II SRAM memory resources
- ◆ Four x4 high-speed serial interconnects to the backplane or PCI Express® (PCIe), Aurora™ or Serial RapidIO® (SRIO)
- ◆ Additional low-speed I/Os to the backplane
- ◆ FusionXF Development Kit for HDL development
- ◆ 3U VPX with .8" Pitch
- ◆ Air and conduction-cooled options

### Benefits

- ◆ Dense FPGA resource in small 3U form factor
- ◆ Maximum I/O flexibility to front panel and backplane
- ◆ Excellent infrastructure for HDL development and host interaction
- ◆ Versatility for deployed or commercial environments

### Overview

The FPE320 is a 3U VPX FPGA processor board that incorporates the largest Xilinx® Virtex®-5 FPGAs available with an FMC mezzanine site. Providing many resources in a small, rugged form factor, the FPE320 is the ideal FPGA platform for 3U systems that need to acquire analog and other high-speed I/O, or that need a large FPGA processor.

Figure 1: FPE320 Architecture

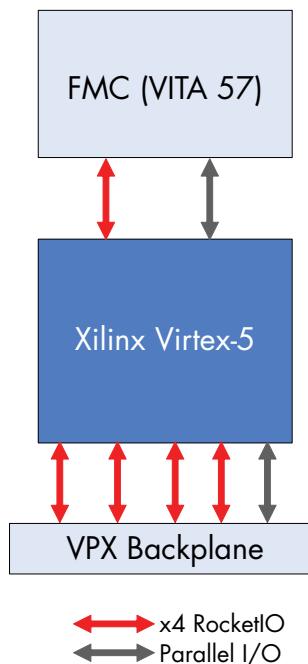

FPGAs have been become popular due to their impressive

Learn More

Web / [sales.cwembedded.com](http://sales.cwembedded.com)

Email / [sales@cwembedded.com](mailto:sales@cwembedded.com)

**ABOVE & BEYOND**

**CURTISS  
 WRIGHT** Controls  
 Embedded Computing  
[cwembedded.com](http://cwembedded.com)



Table 1: FPE320 FPGA Resource Table

	Logic Resources			Memory Resources			Clock Resources		Embedded Hard IP Resources & Speed Grades*				
	Slices	Logic Cells	CLB Flip-Flops	Max. Dist. RAM (kbits)	Block RAM/FIFO w/ ECC (36 kbits each)	Total Block RAM (kbits)	Digital Clock Mgrs. (DCMs)	Phase Locked Loop (PLL)/PMCD	DSP48E Slices	PCIe Endpoint Blocks	PowerPC™ 440 Blocks	Speed Grade	RocketIO™ GTP (run at 3.125GHz or lower)
LX330T	51,840	331,776	207,360	3,420	324	11,664	12	6	192	1	0	-1	20
LX220T	34,560	221,184	138,240	2,280	212	7,632	12	6	128	1	0	-1	16
LX155T	24,320	155,648	97,280	1,640	212	7,632	12	6	128	1	0	-1	16
SX240T	37,440	239,616	149,760	4,200	516	18,576	12	6	1,056	1	0	-1	20
FX200T	30,720	196,608	122,880	2,280	456	16,416	12	6	384	1	2	-1	20
FX130T	20,480	131,072	81,920	1,580	298	10,728	12	6	320	1	2	-1	20

\* Note: These features are specific to using the FPGAs on the FPE320 and do not reflect all of the capabilities of the FPGAs themselves.

processing power, as well as their ability to meet size, weight, and power (SWaP) limitations. The inherent parallelism of FPGAs makes them well suited for a variety of image and signal processing applications that have historically been satisfied with a large array of general purpose processors. When complex algorithms are partitioned into FPGAs, users can see increases in performance that can lead to a dramatic reduction in slot count and system cost, both important factors in 3U systems.

As system platforms have grown smaller, many designers have considered 3U boards. 3U VPX has provided an ideal platform for high-speed serial interconnects (HSSI) such as PCI Express® (PCIe), Aurora™, and Serial RapidIO® (SRIO) to the backplane, but board constraints have limited the use of large FPGAs with I/O. With the advent of the FMC mezzanine site, or FPGA mezzanine site (see FMC overview, page 5), large FPGAs can be used in 3U systems because the I/O space requirements are minimized. FMC is a standard conceived to allow designers to take advantage of advances in the latest I/O (ADCs, DACs, etc.), coupling it directly to FPGAs. This allows users to take advantage of low latency and high-bandwidth that FPGAs support, while the flexibility of FMC eases design for multiple I/Os and allows for dissipating heat more effectively. The FPE320 combines the I/O resources of the FMC with the backplane connectivity of 3U VPX to maximize the effectiveness of these many FPGA resources. The FPE320 is supported by the FusionXF Development

Kit, which provides infrastructure and support for HDL development, software, and multi-processing applications, including PCIe, Aurora™ and SRIO. The processors that interact with the FPE320 support the Wind River® VxWorks® and Wind River® GPP Linux® operating systems.

### Xilinx® Virtex®-5 FPGA

At the heart of the FPE320's processing is a Xilinx® Virtex®-5 FF1738 package FPGA, the largest FPGA in the Virtex®-5 family. FPGAs provide parallel processing capabilities that can be used to reduce processor count and system size. Operations such as FFTs, FIR filters and other fixed-point and/or repetitive processing tasks are highly suited for placement inside FPGAs. A large FPGA node allows processing tasks to tackle input from the FMC mezzanine site or backplane I/O, or can simply function as an adjunct compute resource to the general purpose system processor.

The FPE320 supports Xilinx® Virtex®-5 LXT, SXT, and FXT devices. Using the LXT for logic-intensive applications, the SXT for DSP applications, and the FXT for all-around performance, developers can tailor their hardware resources to match their algorithm needs (see the FPE320 FPGA resource table).

Curtiss-Wright Controls Embedded Computing supports



the LX330T, LX220T and LX155T devices in the LXT family. With over 330,000 logic cells, the LXT family gives FPGA designers the most amount of space to program their algorithm. Within the SXT family, the SX240T device is supported. With 1,056 DSP slices and over 240,000 logic cells, the SXT device is ideal for A/D projects where the DSP48E slices can be used to maximum benefit. Curtiss-Wright Controls supports the FX200T and FX130T devices of the FXT family, which combines the advantages of LXT and SXT. The FXTs provide ample Block RAM and two embedded PowerPCs™.

### Larger Chips Reducing Development Time

The use of large FPGA nodes simplifies algorithm development as processing can be done inside a single device or a reduced number of devices. When compared with the smaller package FPGAs, the larger FPGAs have more logic slices available. The availability of more logic gives designers greater freedom, making timing easier to close, and hence shortening development cycles. Additionally, as more FPGAs are used, greater complexity is needed to partition the algorithm and link the devices together. These I/O resources come at a greater expense in smaller devices, which already have less logic. When combined with a large amount of memory and I/O resources, the larger devices can fulfill processing needs for a variety of applications while still easing customer development.

Table 2: Virtex®-5 FPGA Package Comparison

	Logic Resources		
	Slices	Logic Cells	CLB Flip-Flops
LX330T	51,840	331,776	207,360
2x LX155Ts	48,640	311,296	194,560
LX155T	24,320	155,648	97,280
SX240T	37,440	239,616	149,760
2x SX95Ts	29,440	188,560	117,760
SX95T	14,720	94,280	58,880

The Virtex®-5 FPGA Package Comparison Table compares the larger FF1738 package versus the FF1136 package in the LXT and SXT families.

When comparing one LX330T versus two LX155Ts (both the largest device in their respective packages), the LX330T has more slices and more logic cells. Given that a large

fabric interface such as PCIe will consume a fixed amount of resources, the LX330T is a much more suitable choice for large logic designs. When comparing the SX240T against two SX95Ts, the advantage of having more logic available is even more apparent. The SX240T has over 25% more logic available than two SX95Ts. As much as this benefit applies to single-chip designs, it is even more apparent when algorithms span multiple boards.

### FPGA Architecture

The FPGA nodes on the FPE320 have industry-leading I/O and memory resources to maximize the effectiveness of the devices in a variety of applications.

Figure 2: FPGA Memory and I/O Architecture

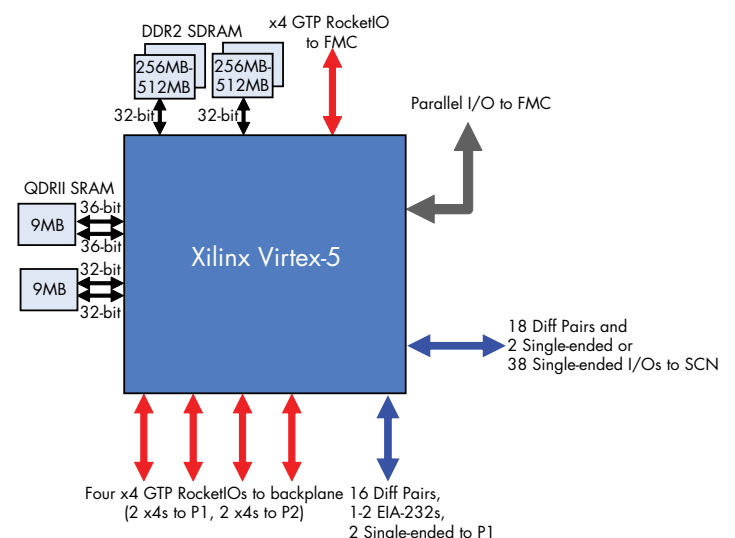

### Memory

The memory resources on each FPGA node of the FPE320 gives users the ability to process and store data sets for the most demanding applications.

Each FPGA node has both DDR2 and QDRII SRAM available. The DDR2 is organized into two banks, with each bank providing a x32 bus width using two x16 devices. Up to 512MB of memory is available from each DDR2 bank, providing a large amount of storage space for data sets. Complementing the DDR2 are two independent banks of QDRII SRAM, for more processing intensive tasks. The banks each have a x36 bus width, and provide immense



bandwidth as they are quad data rate. The QDRII banks do not need to track addressing because they are SRAMs, shortening development time for the user. Each bank is 9MB, for a total of 18MB available from each FPGA.

12MB of flash is available for storing bit-streams, although they can also be loaded through the System Controller Node (SCN).

### FPGA I/O

The FPGA node on the FPE320 an enormous number of I/O resources for connecting to other parts of the system. In terms of RocketIO™ high-speed serial links, the FPGA compute node utilizes up to 20 RocketIOs depending on which package is used. For the larger devices, such as LX330T, SX240T and FX200T, 20 links are used. These links are divided between I/O to FMC and to the backplane. Parallel I/O is also used, with up to 164 lines routed to the dedicated FMC site, and 38 single-ended I/Os or 18 differential pairs and two single-ended I/Os routed to the SCN.

Table 3: GTP Speed/Clock Sources

Speed	Protocol	Clock Source
3.125Gbps	Aurora™, SRIO type 3	156.25MHz
2.5Gbps	Aurora™, Serial FPDP, PCIe, SRIO type 2	125MHz
2.125Gbps	Aurora™, Serial FPDP, 2x Fibre Channel	106.25MHz
1.25Gbps	Aurora™, 1x Gigabit Ethernet	125MHz
1.0625Gbps	Aurora™, Serial FPDP, 1x Fibre Channel	106.25MHz

### Cabling

A JTAG cable is included with the board for programming of the FPGA.

### System Control & Chassis Management

The on-board SCN controls chassis management, temperature monitoring, JTAG, bit-stream encryption, and routing of single-ended I/Os. Users can take advantage of Curtiss-Wright Controls' default HDL functionality or program their own logic into the SCN. The SCN has 128MB of local DDR2 available for quick loading of bit streams using a 16-bit bus, and also has 4MB of flash available for storing FPGA images. The SCN's ability to function as a switch for single-ended I/Os can be seen in the SCN I/Os diagram.

The SCN manages the images for itself and also for the

FPGA processor. Images can be uploaded and stored in flash or SDRAM. SDRAM has the added advantages of speed and not retaining data when powered off. The volatile aspect of SDRAM is useful for some secure applications where no trace can remain when the board is not in use. The SCN also acts as a JTAG player.

Figure 3: Differential Pairs and Single-ended I/Os

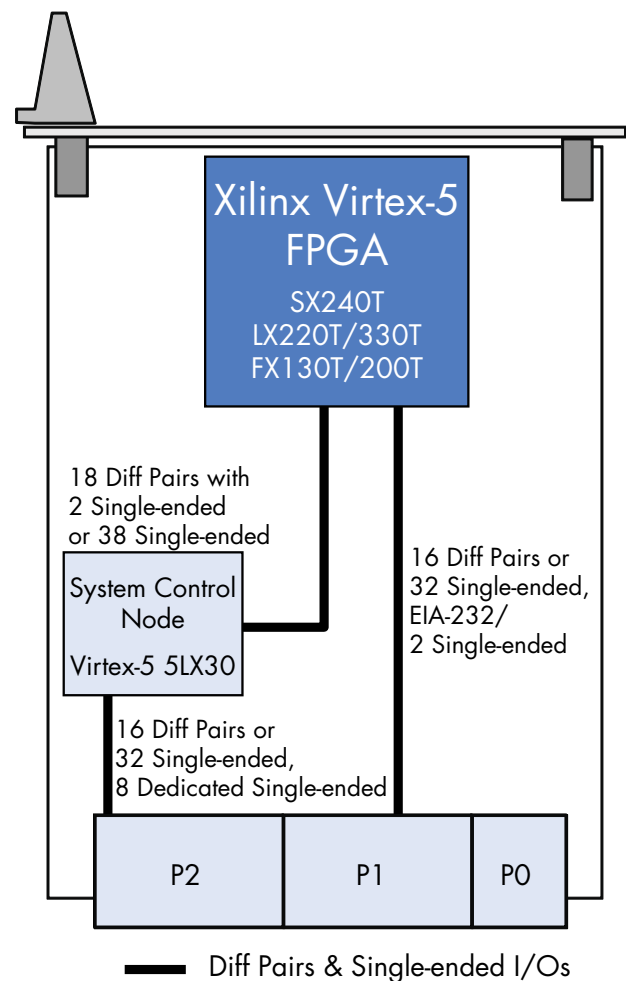

### Backplane I/O



The backplane connectivity is shown below:

Figure 4: Backplane I/O connectivity

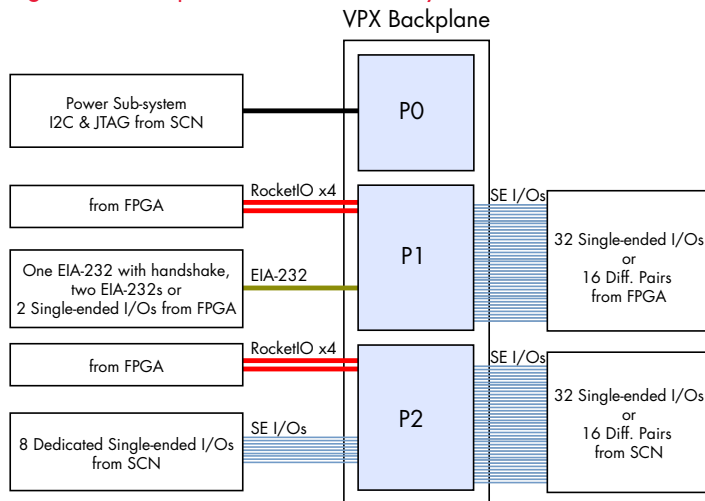

## Mezzanine Site

The FPE320 includes a versatile set of I/O options through a FPGA Mezzanine Card (FMC) mezzanine site (VITA 57). FMCs provide flexibility for the latest I/O such as A/D converters, Serial FPDP (sFPDP), LVDS, and can also be designed by customers by following the VITA 57 standard.

## FMC Site

The VITA 57 FMC site utilizes 120 user I/O pins from the dedicated FPGA nodes:

- ♦ LA[00-33]\_P/N = 37 differential pairs / 68 single-ended with DCI termination
- ♦ HA[00-16]\_P/N = 17 differential pairs / 34 single-ended with DCI termination
- ♦ HB[00-08]\_P/N = 17 differential pairs / 18 single-ended. No DCI termination

Customer developed, third party, or Curtiss-Wright Controls FMC modules can be used with the FPE320. Announced FMC products from Curtiss-Wright Controls include analog I/O boards which can be used to tailor the I/O capabilities of the FPE320 to customer project specific needs.

## Software and HDL

## FMC (VITA 57)

Traditional open standard bus-based structures (for example, PCI-X) for I/O operations are less suitable for FPGA I/O, because they can slow data transfer rates while consuming valuable FPGA resources. FPGA I/O is inherently configurable and can be adapted to a wide range of I/O structures. FPGA I/O is best optimized when FPGAs are not treated the same way as CPUs, but connected directly with I/O devices or ports. The VITA 57 FMC open standard has been developed to capitalize on these FPGA attributes.

The FMC standard provides an industry standard mezzanine form factor in support of a flexible, modular I/O interface to an FPGA located on a baseboard or carrier card. It allows the physical I/O interface to be physically separated from the FPGA design while maintaining a close coupling between a physical I/O interface and an FPGA through a single connector, P1.

There is a choice of two different (very high-bandwidth) connectors to interface the FMC to an FPGA on a carrier: a Low Pin Count (LPC) connector with 160 pins and a High Pin Count (HPC) connector with 400 pins. An FMC with the LPC connector can mate with a carrier that utilizes either an LPC or HPC connector.

The use of the FMC standard simplifies FPGA designs, reduces cost, and makes the design of I/O mezzanine modules simple and straightforward. Development cycles can be shortened and costs lowered by utilizing a single FPGA design in multiple applications, by simply mounting different FMC modules.

Typical FMC modules will have an I/O device, such as an ADC (with front end signal conditioning), buffer and connectors. Since FPGAs can interface directly to I/O devices' I/O pins, there is no need for bus interfaces (e.g., PCI) eliminating the need for bus converters and their associated overhead

FMCs can be used to provide analog I/O, digital I/O, fiber-optic interfaces, camera interfaces, frame grabbers, additional memory or even dedicated DSP functions.

FMC modules are about half the size of PMC or XMC modules (similar width), but provide higher density host I/O.

Key FMC features include:

- ♦ Up to 192 differential I/O pairs
- ♦ Up to 10 high-speed serial I/O links
- ♦ Air and conduction-cooled variants
- ♦ Module size 69 x 76.5mm



## FusionXF FPGA Development Kit

The FPE320 uses the Curtiss-Wright Controls FusionXF FPGA Development Kit to speed HDL development and to communicate with processors and other FPGAs in a system. FusionXF provides FPGA Hardware Development Logic (HDL) functions, application APIs, drivers, and utilities to simplify the task of integrating FPGAs into an embedded real-time DSP system design. It aids customers in the development of their FPGA algorithms and logic for Curtiss-Wright Controls' customer-programmable FPGA Products, by providing all the building blocks to build a fully functional FPGA design to which a customer can integrate their FPGA logic and algorithms. FusionXF also provides mechanisms for communication between FPGAs as well as communication between FPGAs and processors. It includes example designs that show how to implement common FPGA functions such as control registers, DMA engines and interrupts, etc. and how to control these functions and communicate with them from software.

FusionXF is comprised of a Software Development Kit (SDK) and a Hardware Development Kit (HDK). The FusionXF SDK contains software libraries, drivers, and utilities for use in Windows®, Wind River® VxWorks®, and Wind River® GPP Linux® environments to facilitate the initialization and control of FPGAs and to communicate and move data between FPGAs and application software. Software drivers and libraries are provided to allow processing nodes to utilize FPGAs as co-processors, DMA engines, and memory pools. Utilities are provided to perform useful functions, such as loading new images into the FPGA's flash memory.

The FusionXF HDK contains HDL functions that are common to most FPGA applications. There are HDL functions provided as DDR and QDR memory controllers, RocketIO™ interfaces, parallel I/O interfaces, and commonly used FPGA functions such as DMA engines and register sets. In addition, there are HDL functions provided to implement protocols such as PCIe. The hardware independent HDL code resides in the VM Library. The hardware dependent HDL code resides in the BSIP.

## Example Applications

In Example 1, a three-slot system is shown with a tuner board, the FPE320, and a general purpose processor board with an XMC site. This small system provides a powerful signal processing engine that previously would have been done in a 6U system. The tuner processes data, and passes it along to the FPE320 using RocketIO™, most likely using the Aurora™ protocol. The FPE320 can then apply its large FPGA resources to the data, performing

a variety of digital functions. The FMC is capable of outputting data for recording purposes, sending analog data to another source using a D/A FMC, or doing analog to digital conversion should the tuner output analog rather than digital data. The FPE320 is also acting as a bridge between the RocketIO™ coming from the tuner, and the PCIe x8 interface to the processor board. The processor can then complete the processing, before outputting the data (using its XMC site) to storage or a display. All of this activity occurs in a three-slot system, nicely tailored to applications with limited SWaP requirements.

Figure 5: Example 1

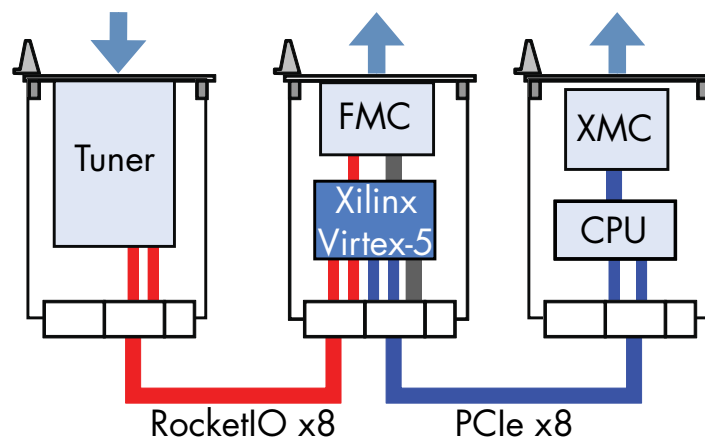

In Example 2, a five-slot system is shown with four FPE320s and a processor board. Two interconnects are working in concert on the backplane. PCIe is used as the connection between the processor board and the FPE320s, allowing a data path to a general purpose processor, and providing the command and control infrastructure for the system. RocketIO™ is daisy-chaining the FPE320s together, providing a low-overhead, high-throughput infrastructure for the FPGAs to communicate with one another. A standard FMC from Curtiss-Wright Controls is the ADC510, which provides two 12-bit, 500MSPS channels of input to the FPE320. After this data is processed, it can travel to other FPE320s, or go directly to the processor using PCIe, before leaving the system. By leveraging the ability to add multiple FPE320s to a system, system designers can easily add additional channels and/or FPGA resources with a high-speed fabric, while still maintaining connectivity with a general purpose processor.



Figure 6: Example 2

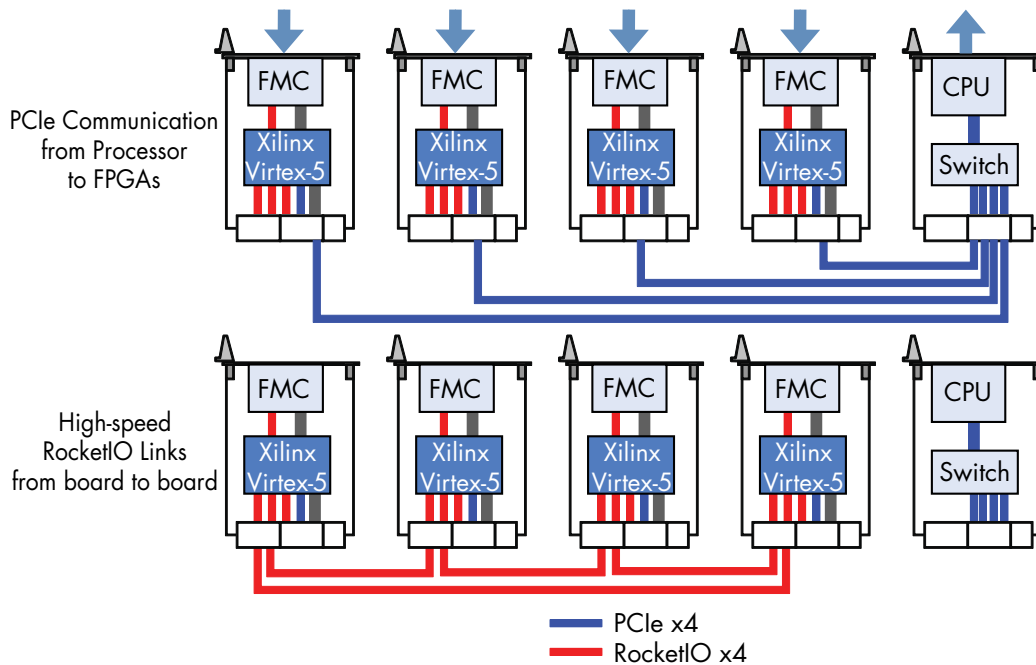

Figure 7: FPE320 Block Diagram

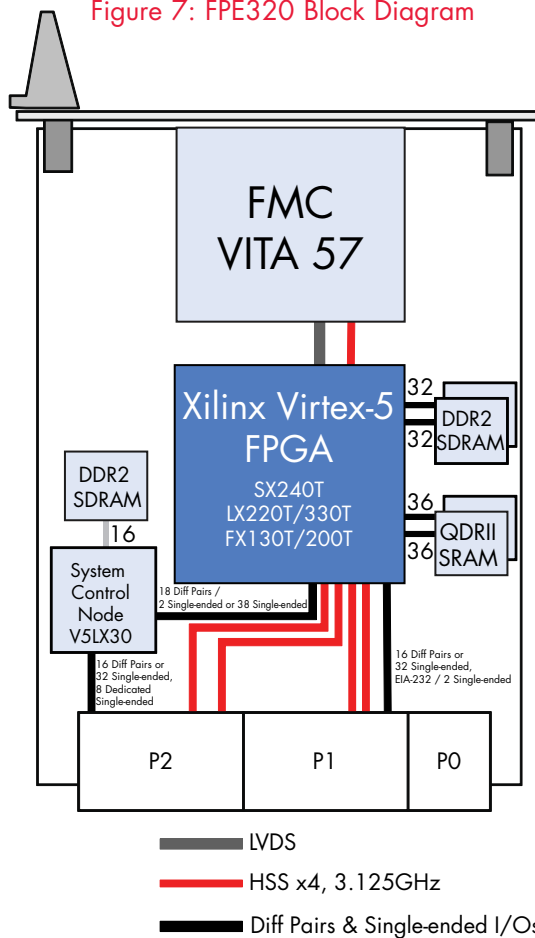



Table 4: Specifications

FPGA Compute Node	
Device	Xilinx® Virtex®-5 LX155T, LX220T, LX330T, SX240T, FX130T & FX200T
No. of FPGAs	1
Memory (per FPGA)	2x 9MB QDRII SRAM (36-bit data paths) 2x 256-512MB DDR2 SDRAM (32-bit data paths) 12MB flash (for storing FPGA images only)
Connectivity	2 x4 GTP RocketIOs to P1 2 x4 GTP RocketIOs to P2 32 Single-ended I/Os or 16 Differential Pairs to P1 1 EIA-232 with HandShake (CTS/RTS), Dual EIA-232, or 2 Single-ended I/Os to P1 38 Single-ended I/Os or 18 Differential Pairs and 2 Single-ended to the SCN
System Control Node	
Device	Xilinx® Virtex®-5 LX30
Memory	128MB DDR2 SDRAM (16-bit wide) 4MB flash (for storing FPGA images only)
Connectivity	32 Single-ended I/Os or 16 Differential Pairs to P2 8 Dedicated Single-ended I/Os to P2 38 Single-ended I/Os or 18 Differential Pairs and 2 Single-ended to the FPGA processor Dual I2C buses to P0
Configuration	JTAG, SCN, off-board I/Os and on-board flash
Mezzanine Site	FMC/VITA 57 Quad RocketIO™ x1, 73 Differential Pairs and 2 Single-ended for LX330T/SX240T/FX200T 68 Differential Pairs and 8 Single-ended for LX220T/FX130T
PCI Express	
Connectivity	Default configuration is PCIe x8 to P1 & RocketIO™ x8 to P2
Compliance	VPX (VITA 46) & VPX REDI (VITA 48)

Connectivity	
P0	Power, JTAG & SCN utility signals (I2C)
P1	2 x4 GTP RocketIOs 32 Single-ended I/Os or 16 Differential Pairs 1 EIA-232 with HandShake (CTS/RTS), Dual EIA-232, or 2 Single-ended I/Os
P2	2 x4 GTP RocketIOs to backplane 32 Single-ended I/Os or 16 Differential Pairs 8 Dedicated Single-ended I/Os
Software/HDL Code	
Operating System	Wind River® VxWorks® 6.5, Wind River® GPP Linux® 2.6.x (run on adjoining processor, not FPE320)
Utilities	Flash programming, diagnostics
HDL Code	FusionXF FPGA Development Kit
Standards	
Compliance	VITA 46.0, 46.4, 48
Board Pitch	.8"
Miscellaneous	
Power	VPX +5V (2.5W), +12V (44.4W)
Cabling	JTAG Cable and Adapter (p/n JTAG-1001)
Weight	1.05lbs (0.047kg)



**Table 5:**  
**Environmental Specifications**

Part Number Extension <sup>1</sup>		Commercial	Rugged		
			Air-cooled	Conduction-cooled	
				Level 3	Level 4
-		-	-C2H	-E4H	-E6H
Temperature	Operational (at sea level)	0°C to +55°C (15 CFM air flow) <sup>2</sup>	-40°C to +70°C (20 CFM air flow) <sup>2</sup>	-40°C to +70°C (Card Edge Temp) <sup>3</sup>	-40°C to +85°C (Card Edge Temp) <sup>3</sup>
	Non-Operational	-40°C to +85°C	-50°C to +100°C	-55°C to +100°C	
Vibration	Operational (Random)	-	0.04g <sup>2</sup> /Hz	0.1g <sup>2</sup> /Hz	
Shock	Operational	-	20g peak, 11ms half sine	40g peak, 11ms half sine	
Humidity	Operational	5-95% non-condensing	Up to 95%	Up to 95%	
Altitude <sup>4</sup>	Operational	-	-15,000 to 60,000ft	-15,000 to 60,000ft	
Conformal Coating <sup>5</sup>		No	Yes	Yes	

**Notes**

1. Availability of the ruggedization levels are subject to qualifications for each product.
2. For operation at altitudes above sea level, the minimum volume flow rate shall be adjusted to provide the same mass flow rate as would be provided at sea level. Additional airflow might be required if the card is mounted together with, or next to, cards that dissipate excessive amounts of heat. Some higher-powered products may require additional airflow.
3. The contacting surface on the rack/enclosure must be at a lower temperature to account for the thermal resistance between the plug-in unit and rack/enclosure.
4. Depending on the technology used, the risk for Single Event Upsets will increase with altitude.
5. Coated with Humiseal 1B31 or 1B73EPA. (ref. <http://humiseal.com> for details)

**Warranty**

This product has a one year warranty.

**Contact Information**

To find your appropriate sales representative, please visit:

Website: [www.cwembedded.com/sales](http://www.cwembedded.com/sales)

Email: [sales@cwembedded.com](mailto:sales@cwembedded.com)

**Technical Support**

For technical support, please visit:

Website: [www.cwembedded.com/support1](http://www.cwembedded.com/support1)

Email: [support1@cwembedded.com](mailto:support1@cwembedded.com)

The information in this document is subject to change without notice and should not be construed as a commitment by Curtiss-Wright Controls Embedded Computing. While reasonable precautions have been taken, Curtiss-Wright Controls assumes no responsibility for any errors that may appear in this document. All products shown or mentioned are trademarks or registered trademarks of their respective owners.