



Data Sheet

UNITRONIX Pty Ltd
 PO Box 486, Morisset NSW 2264
 NSW: Tel: 61 2 4977 3511 Fax: 61 2 4977 3522
 WA: Tel: 61 8 9455 2424 Fax: 61 8 9455 2458
 unitsyd@unitronix.com.au www.unitronix.com.au

Eagle-2

High-resolution Radar Scan Converter PMC

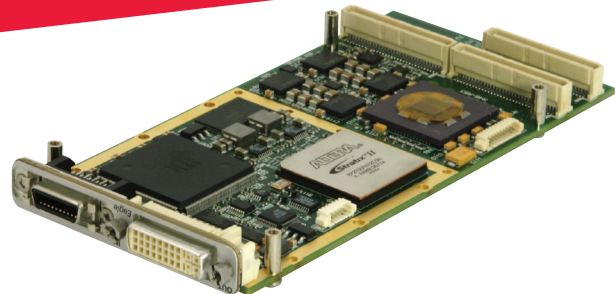

Features

- ◆ High-performance PMC radar scan-converter
- ◆ Supports display resolutions up to 2048 x 2048 and 2560 x 1600
- ◆ Support for radar rotation rates up to 90 rpm
- ◆ Simultaneous scan-conversion of multiple radar sources
- ◆ Multiple radar display windows
- ◆ PPI, A-Scan and B-Scan display modes
- ◆ Support for sector scan, random scan and reverse scan inputs
- ◆ DVI graphics input for digital mixing of radar and graphics
- ◆ Supported by RVL+ software library

Eagle-2 is the latest in the line of high-performance radar scan converters from Curtiss-Wright Controls Embedded Computing. Using field proven scan-conversion algorithms, Eagle-2 provides improved performance and support for high-resolution screen displays making it the perfect choice for high-end radar display applications.

Radar scan conversion on the Eagle-2 is performed using a highly effective algorithm which combines the best features of both forward and reverse scan conversion. The powerful algorithm ensures that there are no holes or spokes in the displayed image, even when zooming-in at long range, and that all single point targets are displayed. Radar data is passed to the card via PCI bus transfers. Data can originate either from a Curtiss-Wright Osiris radar input card or via a network from a radar video server such as Curtiss-Wright's radar video processing (RVP) product.

A key feature of Eagle-2 is the ability to accept a DVI graphics input signal, for mixing with the scan-converted radar. During video keying, the Eagle-2 is able to place the video from the graphics card either as an underlay or as an overlay to the radar image. This feature is typically used in multi-layer display applications to allow target symbols to be presented as overlays and maps to be presented as underlays.

Figure 1 shows how Eagle-2 provides radar display capabilities within a typical radar acquisition and display system.

Eagle-2 is available as a standard version, supporting display resolutions up to 1920 x 1200, and a high-resolution version, supporting up to 2560 x 1600 (including 2048 x 2048).

Learn More

Web / sales.cwembedded.com

Email / sales@cwembedded.com

ABOVE & BEYOND

**CURTISS
 WRIGHT** Controls
 Embedded Computing
cwembedded.com



Figure 1: Eagle-2 Typical Configuration

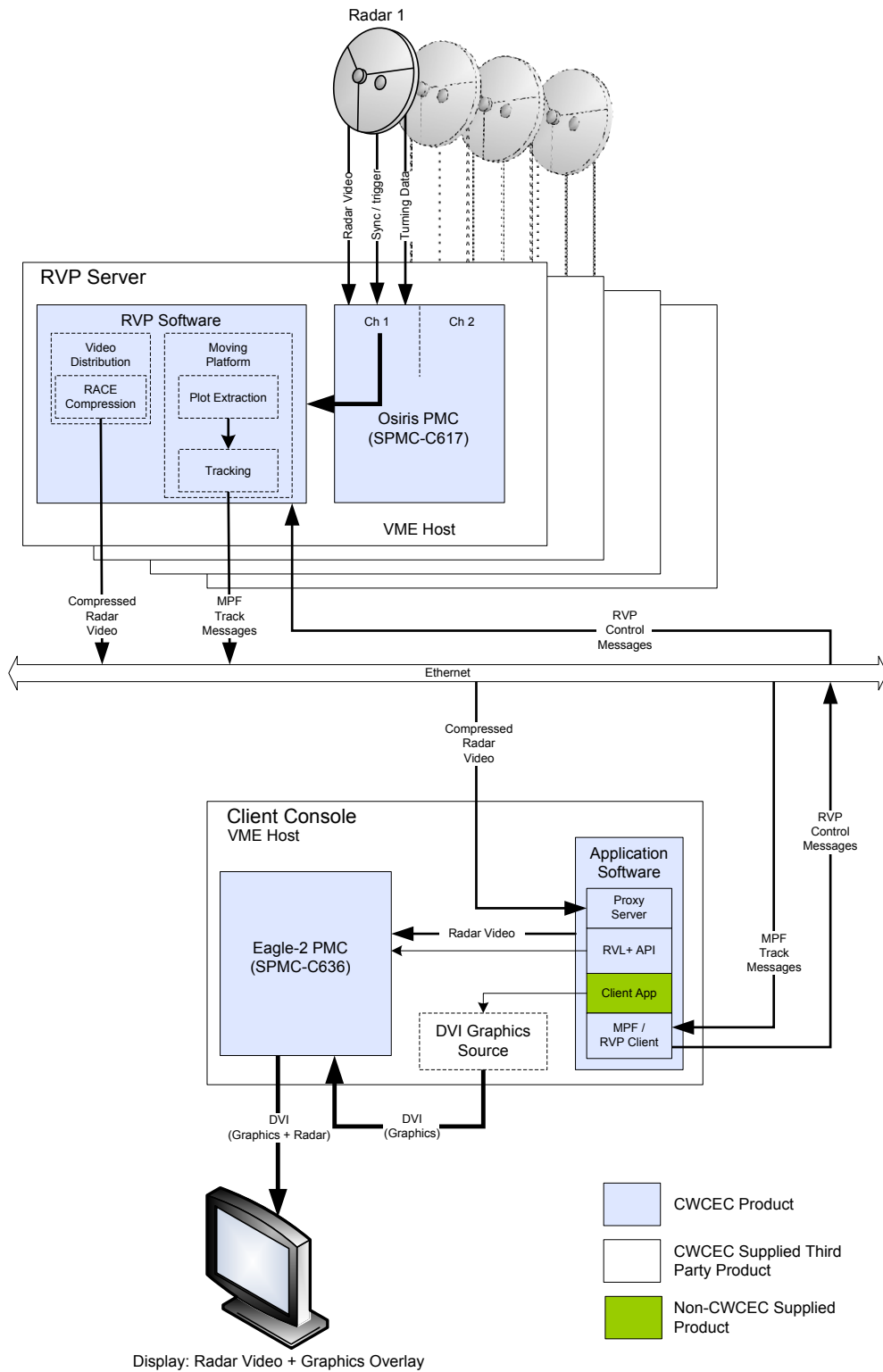

Display: Radar Video + Graphics Overlay



Figure 2: Eagle-2 Architecture

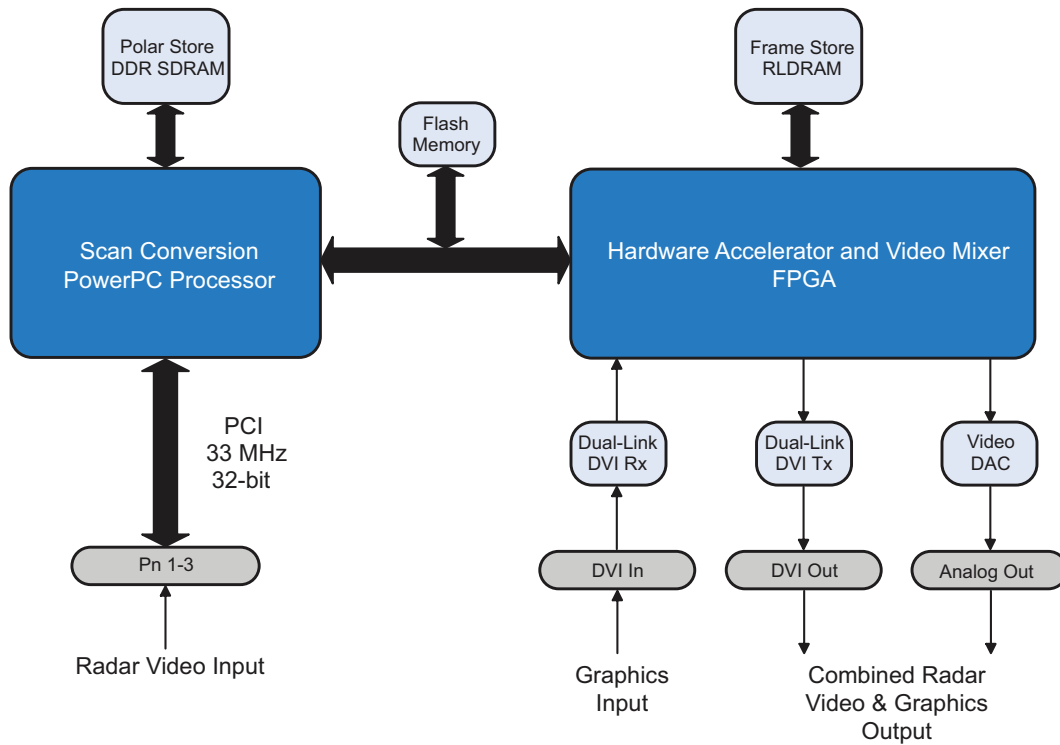

Architecture

Figure 2 shows a block diagram of the Eagle-2 PMC hardware. Digital RGB video from an external graphics source is received by a single-link or dual-link DVI receiver and mixed by the FPGA with scan converted radar video as it is read from the frame buffer RDRAM memory. A dual-link DVI transmitter generates the digital video output while a high-speed digital-to-analog converter provides the analog RGB video output.

The PowerPC® processor stores radar data received over the PCI interface in its polar store DDR SDRAM memory. The processor then implements the scan conversion process resulting in the calculation of source and destination address pairs for each frame buffer pixel to be written. These address pairs correspond to the source address of the radar data held in an SRAM buffer in the FPGA and the destination address of the pixel to be updated in the frame buffer. The processor loads both the address pairs in to a FIFO and the radar data into SRAM in the FPGA. The FPGA starts processing the address pairs and the radar data received from the processor once the FIFO contains new data.

The FPGA contains a display controller which can either lock to the incoming digital video timing or can provide free running fixed format non-interlaced RGB video from pixel data held in the frame buffer memory. When locked to the external video source the in-coming video may overlay the scan converted radar or be mixed (alpha-blended) with it.

Video Output

The Eagle-2 can provide either an analog (non-interlaced) or digital (DVI) video output capability. The digital and analog are output via a DVI-I connector on the PMC front panel.

When an external graphics input is present, Eagle-2 frame locks to the incoming video signal so that the output resolution follows that of the graphics input. When no graphics input is present the onboard display controller generates the internal, non-interlaced video timing required.



The RGB analog video output supports both composite and separate horizontal and vertical synchronization signals. The output can also be configured to provide sync-on-green synchronization.

Eagle-2 incorporates a dual-link DVI output, employing Transition Minimized Differential Signaling (TMDS) technology, supporting display resolutions up to 2560 x 1600 at 60 Hz.

The Eagle-2 board support libraries provide the user with all the necessary tools to select the appropriate output resolutions and synchronization under software control. Table 1 details the output resolutions supported by Eagle-2.

Table 1: Eagle-2 Output Resolutions

Resolution	Refresh Rate (Hz)	Blanking
800 x 600	60	Normal and reduced
1024 x 768	60	Normal and reduced
1280 x 1024	60	Normal and reduced
1600 x 1200	60	Normal and reduced
1920 x 1200	60	Normal and reduced
2048 x 1536	60	Normal and reduced
2048 x 2048	60	Reduced
2560 x 1600	60	Reduced

Figure 3: Eagle-2 Video Mixing Example

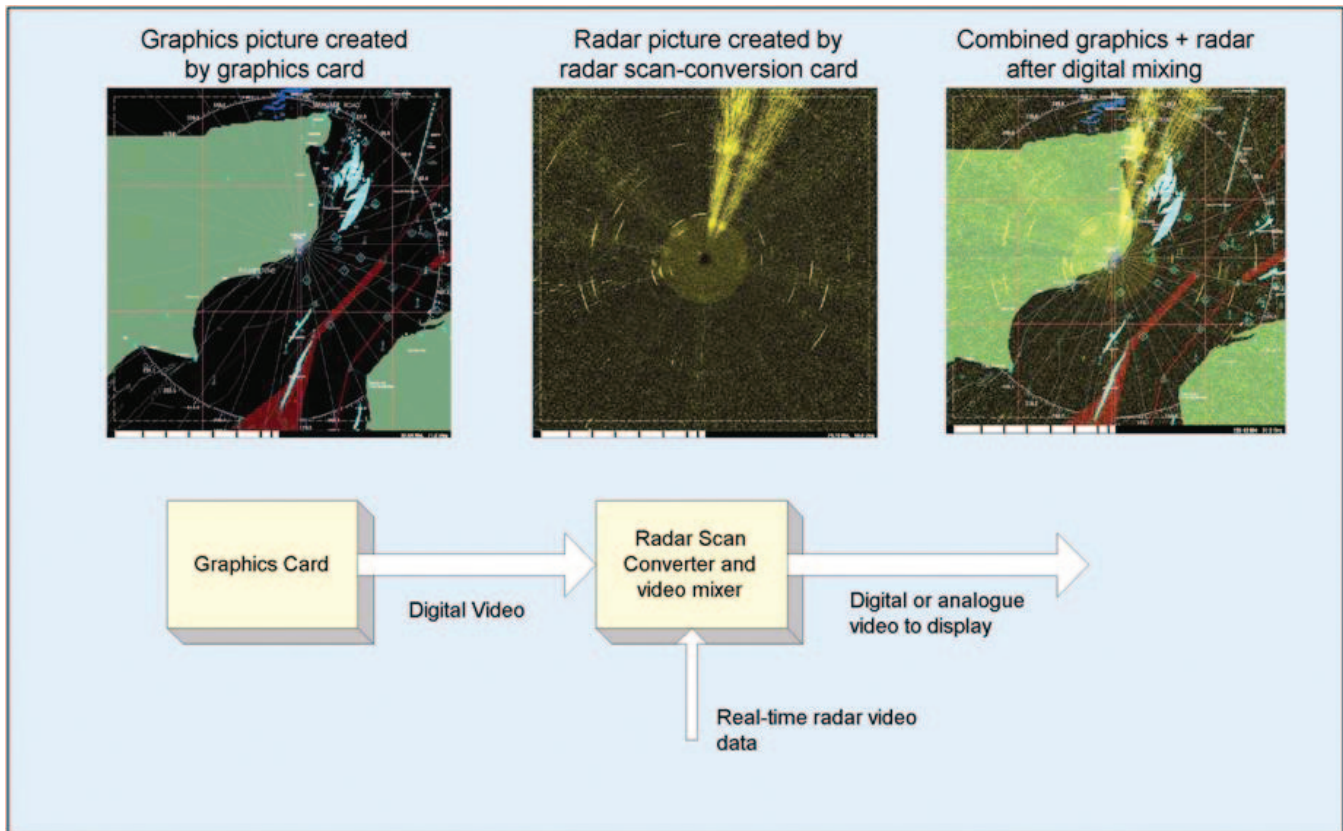



Video Input & Graphics Mixing

Eagle-2 supports the digital mixing of the scan-converted radar with an external graphics video as an underlay and/or overlay to the radar. The external graphics is input via a single-link or dual-link DVI receiver from a MDR20 connector on the PMC front panel. The input video resolutions supported are the same as detailed within the Video Output section.

The pin-out of the MDR20 connector is detailed in table 2.

The FPGA provides the video mixing capability of the Eagle-2 and allows the scan-converted radar to be alpha-blended with the incoming graphics. Mixing is done on a per pixel basis such that, at each pixel, either the alpha-blended radar and graphics (underlay) are displayed or just the graphics (overlay). Eagle-2 provides a look-up table that controls the video keying mechanism used to switch between underlay and overlay. This can be configured to be addressed by either the four most significant or least significant bits of the incoming red, green and blue graphics data.

Table 2: Pin Connections for 20-way MDR Graphics Video Signal Input

Pin	Signal	Pin	Signal
1	DVI_RX_Master_RX0+	11	DVI_RX_CLK+
2	DVI_RX_Master_RX0-	12	DVI_RX_CLK-
3	DVI_RX_Slave_RX0+	13	DVI_RX_Slave_RX1+
4	DVI_RX_Slave_RX0-	14	DVI_RX_Slave_RX1-
5	DVI_RX_Master_RX2+	15	DVI_RX_Master_RX1+
6	DVI_RX_Master_RX2-	16	DVI_RX_Master_RX1-
7	DDC_SCL	17	GND
8	DDC_SDA	18	RX_HOT_PLUG_DETECT
9	DVI_RX_Slave_RX2+	19	DDC_5V
10	DVI_RX_Slave_RX2-	20	GND

Radar Display Functionality

Eagle-2 provides a flexible and powerful method in providing radar scan conversion capabilities for a variety of radar display requirements.

As well as providing the ability to display the scan converted radar in a PPI (Plan Position Indicator) format, Eagle-2 can also provide display data in both A-Scan and B-Scan formats. Up to four radar windows can be created.

Each of the three formats (PPI, A-Scan, B-Scan) can be displayed simultaneously if required. Eagle-2 also supports the display of up to five radar sources within an individual window. The size, position and content of each individual window is fully configurable by the user.

Eagle-2 supports the display of continuously rotating radars as well as supporting display radar inputs in random scan mode (where incoming azimuths are not contiguous), sector scan mode and reverse scan mode.

Up to 256 different fade levels are supported by Eagle-2 with all fade parameters fully configurable by the user. Different fade rates can be applied to different sources within a single window or across multiple windows. Different colors can also be applied to the separate radar sources displayed.

Software Support

Eagle-2 is supported under Curtiss-Wright's common radar and video API, RVL+. This unified API supports a range of radar and video products and helps to further reduce the risk and cost associated with application development and system integration.

Eagle-2 is supported under Linux[®] on Intel[®] x86 host platforms.

For other operating system support please contact your local sales representative.

Variants

Eagle-2 is available as a standard resolution or high-resolution variant. The high-resolution variant supports resolutions up to 2560 x 1600 (including 2048 x 2048) whereas the standard resolution variant supports 1600 x 1200 or 1920 x 1200 with reduced blanking.

Each of the variants mentioned above is available in air-cooled Level 0 and Level 100 ruggedization levels. For conduction-cooled requirements please consult your local sales representative.



Specifications

Architectural & Functional

- ◆ Field proven scan-conversion algorithm
- ◆ Support for radar rotation rates up to 90 rpm at 2048 x 2048 display resolutions
- ◆ Simultaneous display of multiple radar sources
- ◆ Configurable polar store for display of multiple radar sources
- ◆ Multiple color support for scan-converted radar
- ◆ Variable persistence smooth fading with up to 256 levels
- ◆ PPI, A-Scan and B-Scan display formats
- ◆ Integrated digital video keying of radar with graphics input
- ◆ Radar data transfer over bus from local or networked radar source
- ◆ 32-bit, 33 MHz PCI interface

Video Input (from graphics card)

- ◆ Single-link or dual-link DVI
- ◆ Standard version supports resolutions to 1920 x 1200 via single-link DVI interface
- ◆ High-resolution version supports resolutions to 2560 x 1600 (including 2048 x 2048) via dual-link DVI interface

Video Output

- ◆ Single-link or dual-link DVI or analog RGB
- ◆ Supports resolutions to 2560 x 1600 (including 2048 x 2048)
- ◆ Timings derived from graphics input when connected

Performance

- ◆ Typical performance figures:
 - 2k range x 4k azimuth @ 90 rpm displayed onto 2048 x 2048 display
 - 4k range x 4k azimuth @ 60 rpm displayed onto 2048 x 2048 display

Front Panel Connections

- ◆ Video input (digital only) via MDR-20 connector (compatible with DVI-I, DVI-D and MDR-20 graphics cards via adaptor cable)
- ◆ Video output (combined digital and analog) via DVI-I connector

Software, O/S and Host Support

- ◆ API software library: RVL+
- ◆ O/S environment support: Linux
- ◆ Host support: Intel x86
- ◆ For other O/S support please consult factory

Electrical

- ◆ Eagle-2 requires only 5 V from host
- ◆ 11 W (typical) power consumption, based on scan conversion to 2048 x 2048 display

Physical and Mechanical

- ◆ Single-width PMC form factor
- ◆ Size 149 x 74 mm IEEE P1386-2001
- ◆ Weight: 150 g

Environmental

Available in the following Curtiss-Wright environmental grades:

- ◆ Air-cooled Level 0
 - Operating temperature 0° to +50°C
 - Storage temperature -40° to +85°C
- ◆ Air-cooled Level 100
 - Operating temperature -40° to +71°C
 - Storage temperature -55° to +125°C

For further details please see the Curtiss-Wright Ruggedization Table at <http://www.cwembedded.com/0/0/208.html>.



Ordering Information

Table 3: Configuration Options and Part Numbers

Part Number	Description
SPMC-C636-0-0000	Eagle-2 PMC Radar Scan Converter (RSC) - High-resolution version - Screen resolutions up to 2560 x 1600 (inc. 2048 x 2048) - Air-cooled L0
SPMC-C636-0-0010	Eagle-2 PMC Radar Scan Converter (RSC) - Standard resolution version - Screen resolutions up to 1920 x 1200 - Air-cooled L0
SPMC-C636-1-0001	Eagle-2 PMC Radar Scan Converter (RSC) - High-resolution version - Screen resolutions up to 2560 x 1600 (inc. 2048 x 2048) - Air-cooled L100
SPMC-C636-1-0011	Eagle-2 PMC Radar Scan Converter (RSC) - Standard resolution version - Screen resolutions up to 1920 x 1200 - Air-cooled L100

Warranty

This product has a one year warranty.

Contact Information

To find your appropriate sales representative:

Website: www.cwembedded.com/sales

Email: sales@cwembedded.com

Technical Support

For technical support:

Website: www.cwembedded.com/support1

Email: support1@cwembedded.com

The information in this document is subject to change without notice and should not be construed as a commitment by Curtiss-Wright Controls Embedded Computing. While reasonable precautions have been taken, Curtiss-Wright assumes no responsibility for any errors that may appear in this document. All products shown or mentioned are trademarks or registered trademarks of their respective owners.