



Data Sheet

**UNITRONIX Pty Ltd**

PO Box 486, Morisset NSW 2264

NSW: Tel: 61 2 4977 3511 Fax: 61 2 4977 3522

WA: Tel: 61 8 9455 2424 Fax: 61 8 9455 2458

unitsyd@unitronix.com.au www.unitronix.com.au

# Osiris

## PMC/PCI High-performance, Dual-channel Radar Interface

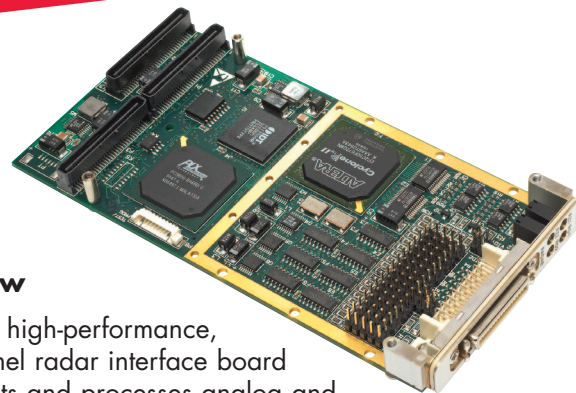

### Features

- ◆ Dual-channel, dual-trigger radar interface card
- ◆ PMC or half-length PCI form factor
- ◆ Supports two Analog inputs (four on Osiris-B), and up to eight digital input bits with flexible video mixing options
- ◆ Gain and offset control as a function of range
- ◆ Flexible LUT-based digital filtering including low- and high-pass
- ◆ BIT generator with multiple test patterns
- ◆ Dual-azimuth input (supports ACP/ARP, RADDs, serial and parallel formats)
- ◆ Flexible input configuration options (single-ended/differential, termination)
- ◆ Correlation in azimuth and range
- ◆ Sampling rate up to 50 MHz on each channel
- ◆ Fully programmable sampling for radar ranges from 0 to 500 NM with up to 16 k samples per return
- ◆ 64-bit 66 MHz PCI interface (32-bit on PCI version)
- ◆ Board-support library with Linux and Windows drivers
- ◆ Supported by RVP for radar tracking, plot extraction and radar video distribution applications

### Overview

Osiris is a high-performance, dual-channel radar interface board that accepts and processes analog and digital radar signals and provides a PCI interface to applications. Osiris comes from a long history of radar interface products at Curtiss-Wright, with interfaces to support many legacy and modern radar types. With an on-board FPGA and high-speed PCI interface, Osiris offers high performance with two independent channels on a half-length PCI or PMC mezzanine format.

### Operation

Osiris receives all radar video, triggers and azimuth data from a front-panel connector. It can generate two streams of radar video onto the PCI bus. Each of the two streams can process data from a combination of the analog and digital inputs, using one of two sets of trigger and turning data. This allows the card to process a pair of radar videos derived from a single set of azimuth turning data and triggers, or else to process two separate videos derived from two independent radars with their own trigger and turning data.

Capture of the video data into fixed-length returns is initiated by the radar's trigger (sync) signal. Data capture starts at a programmable delay from the active edge of the trigger, with video data processed in range and azimuth to combine multiple samples and returns. In range, the card samples video at up to 50 MHz, reducing the data down to a defined number of samples per return to match

Learn More

Web / [sales.cwembedded.com](http://sales.cwembedded.com)

Email / [sales@cwembedded.com](mailto:sales@cwembedded.com)

**ABOVE & BEYOND**

**CURTISS  
WRIGHT** **Controls**  
Embedded Computing  
[cwembedded.com](http://cwembedded.com)

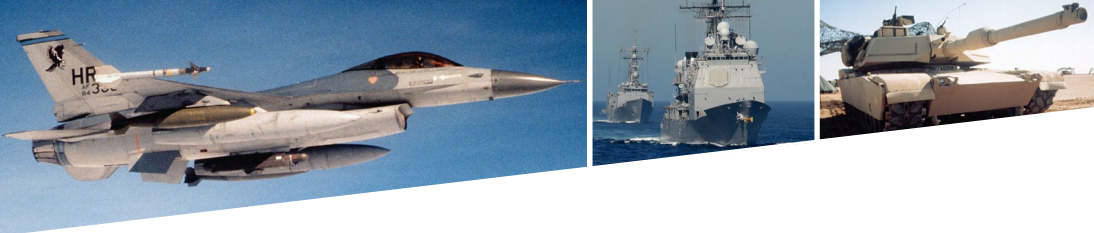

the bandwidth of the incoming video. In azimuth, the card can be programmed to either output every return, or else to combine returns to output a set number per scan, typically 1024, 2048 or 4096. In this mode returns are correlated, typically using a highest-wins combiner, to get the correct number of output azimuths.

Packets of video data are defined with a header and data block and are transferred to the PCI bus with DMA transfers. Osiris is available with a board-support library for integration into custom applications, or else can be supplied with Curtiss-Wright's own Radar Video Processor (RVP) as part of a radar acquisition, processing, distribution or tracking application. The diagram below shows the Osiris PCI card used in a typical radar acquisition and display system.

Figure 1: Typical Osiris Radar System Configuration

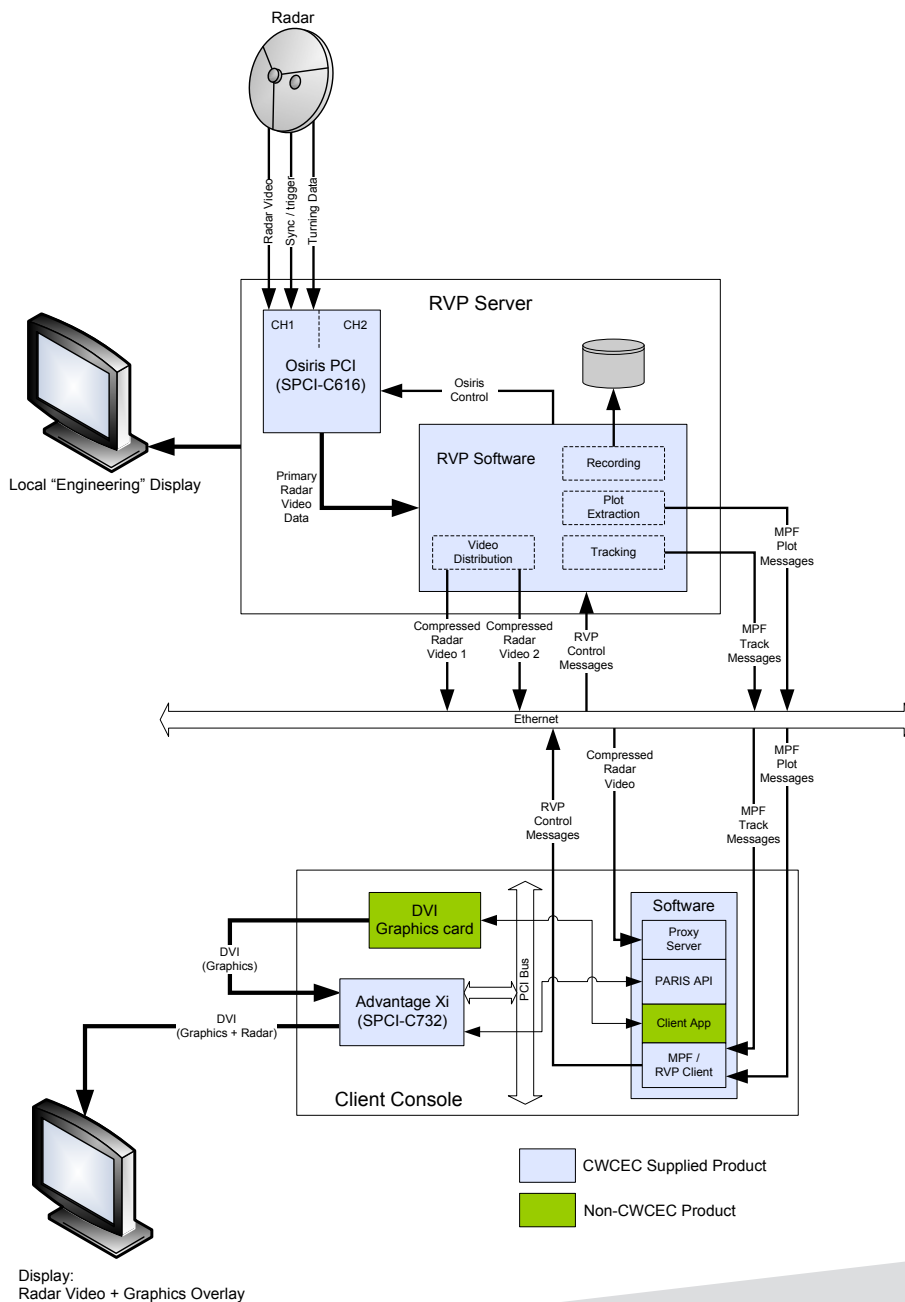

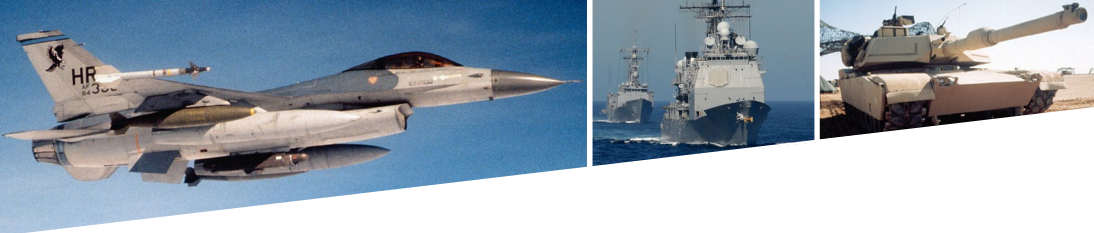

Figure 2: Osiris Block Diagram

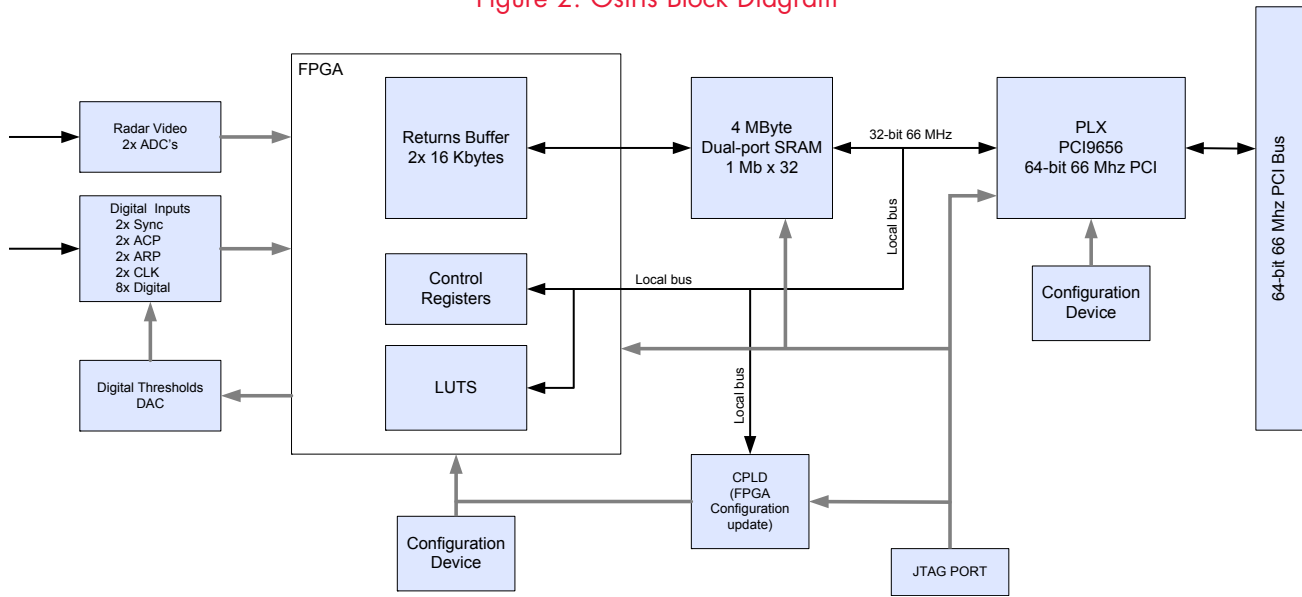
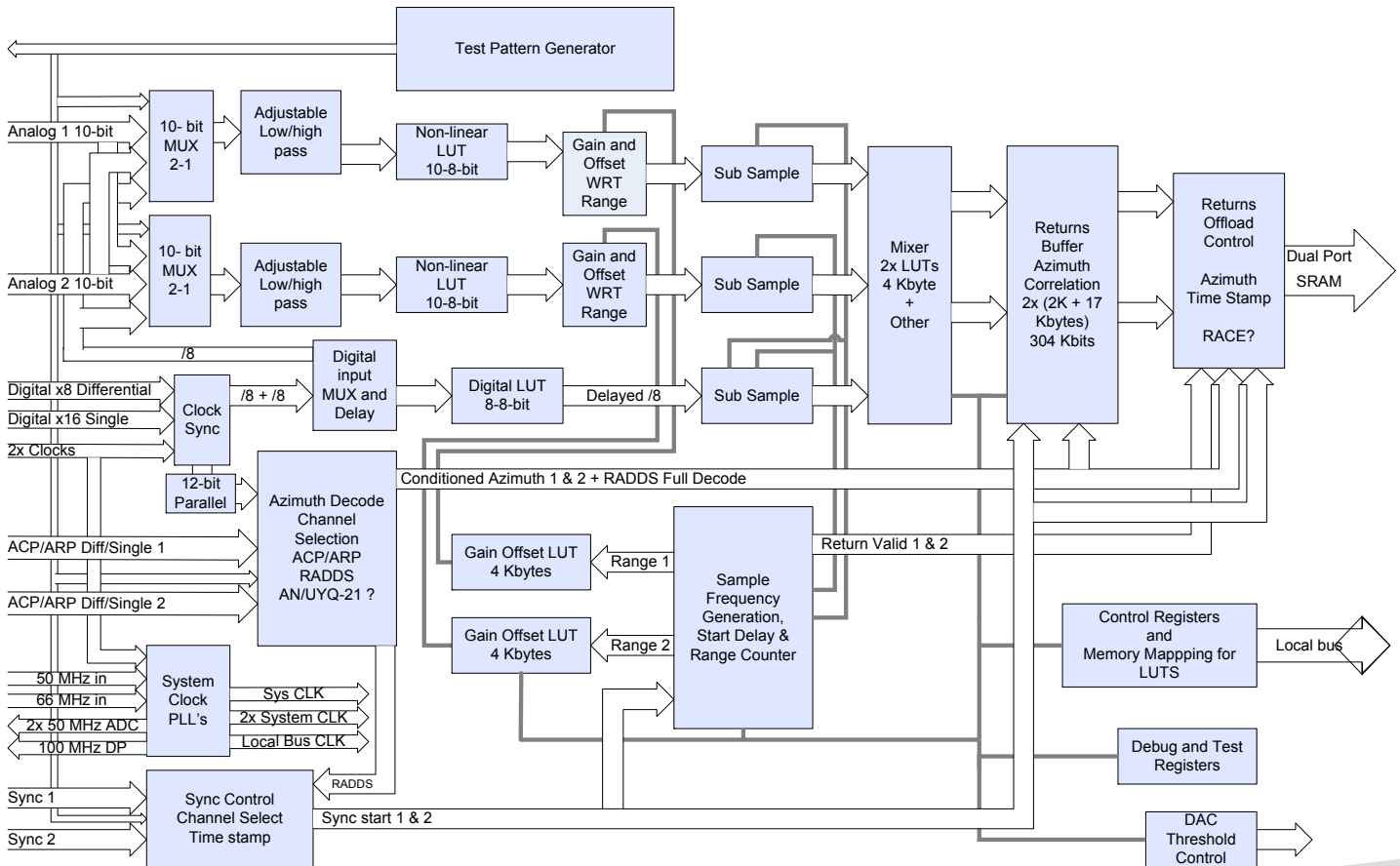

Figure 3: Osiris Internal FPGA Processing



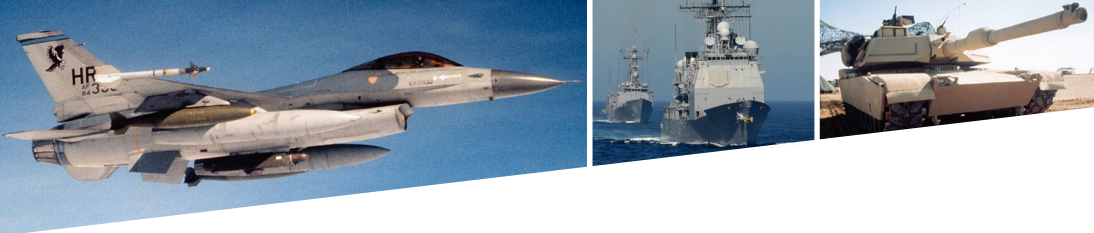
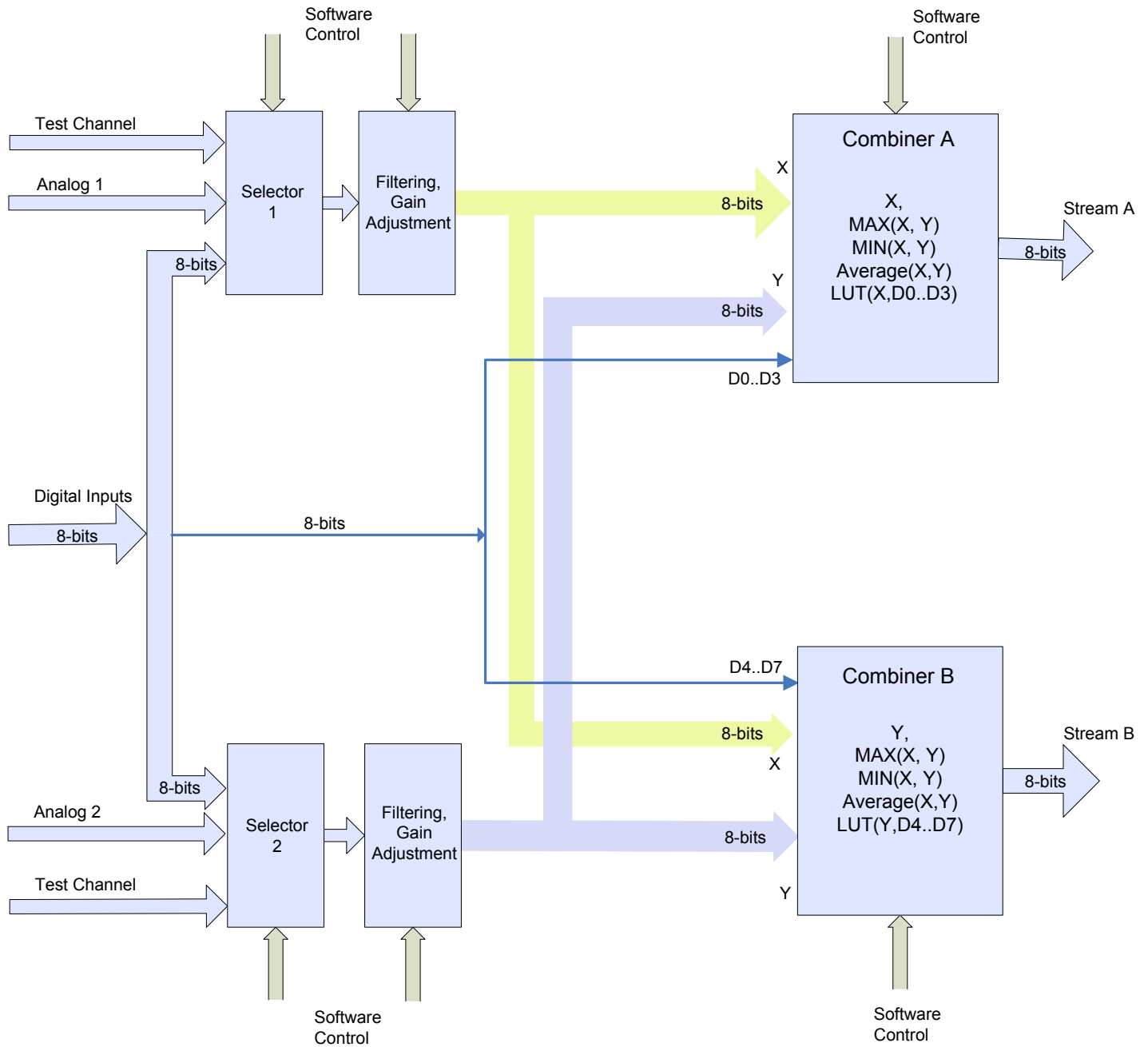

Figure 4: Osiris Video Stream Processing





## Osiris Video Streams

Osiris supports two video output streams, Stream A and Stream B – see Figure 4. The video data associated with each stream is derived from a combination of the two Analog inputs and 8-bits of digital video. With reference to Figure 4, Combiner A accepts three digitized video inputs, X, Y and D0-D3, and Combiner B accepts X, Y and D4..D7. Each of X and Y itself is derived by digitally processing (filtering and gain-with-range adjustment) either an Analog or digital input. X is derived by processing either Analog 1 or 8 digital inputs – the choice being made by Selector 1. Similarly Y is derived by processing either Analog 2 or the same 8 digital inputs.

The A and B Combiners are configured with software to output a combination of X, Y and 4-bits of digital input. The following modes are supported for Stream A:

Stream A = X

In this mode, Stream A is X, where X is derived from either Analog 1 or the 8 digital inputs.

Stream A = MAX (X, Y)

In this mode, Stream A is a highest wins combination of the X and Y inputs. X could be derived from Analog 1 or the 8 digital inputs, and Y could be derived from Analog 2 or the same 8 digital inputs. The highest-wins combination operates on every sample of the return and outputs the sample having the larger value.

Stream A = MIN (X, Y)

In this mode, Stream A is a lowest wins combination of the X and Y inputs. X could be derived from Analog 1 or the 8 digital inputs, and Y could be derived from Analog 2 or the same 8 digital inputs. The lowest-wins combination operates on every sample of the return and outputs the sample having the smallest value.

Stream A = AVERAGE (X, Y)

In this mode, Stream A is the average of the X and Y inputs.

Stream A = LUT (X, D0..D3)

In this mode, Stream A is output as a combination of the X input and 4-bits of digital video D0..D3. A look-up table (12-bits) is used to create an 8-bit value from the combination of 8-bits of Analog and 4-bits of digital. It should be noted that the digital bits are direct from the input and are not subject to the filtering or gain adjustment that happens on the X/Y processing.

Stream B supports similar processing. Using the Combiners and the Selectors under software control, a number of options are available for Streams A and B. Some typical scenarios are shown in the table 1 below.

Table 1: Typical configurations

Configuration	Selectors	Combiners
Analog Video 1 on Stream A, Analog Video 2 on Stream B	Selector 1 = Analog Selector 2 = Analog	Combiner A = X Combiner B = Y
Analog Video 1 on Stream A, Digital Video 2 on Stream B	Selector 1 = Analog Selector 2 = Digital	Combiner A = X Combiner B = Y
Analog Video 1 on Stream A, Analog Video 2 on top 4-bits of Stream B Digital Video inputs on lower 4-bits of Stream B	Selector 1 = Analog Selector 2 = Analog	Combiner A = X Combiner B = LUT (Y, D <sub>4</sub> ..D <sub>7</sub> )
Digital Video (4-bits) on Stream A, Highest wins of Analogs 1 and 2 on Stream B	Selector 1 = Analog Selector 2 = Analog	Combiner A = LUT (X, D <sub>0</sub> ..D <sub>3</sub> ) Combiner B = MAX (X, Y)  Although the LUT for Stream A takes in X and D <sub>0</sub> ..D <sub>3</sub> , the output depends only on the digital bits



## Osiris Radar Input Connector

The Osiris input connector is a 0.050" pitch MDR receptacle.

Table 2: Osiris radar input connector pinout

Pin	Function	Alternative	Pin	Function	Alternative
1	Radar (H1)	Radar1	19	DIG2(H)	Dig2
2	DIG1(H)	Dig1	20	Radar1(L)	Gnd
3	Sync1(H)	Sync1	21	DIG2(L)	Gnd/Dig10
4	DIG1(L)	Gnd/Dig9	22	Sync1(L)	Gnd
5	Radar2(H)	Radar2	23	DIG4(H)	Dig4
6	DIG3(H)	Dig3	24	Radar2(L)	Gnd
7	Sync2(H)	Sync2	25	DIG4(L)	Gnd/Dig12
8	DIG3(L)	Gnd/Dig11	26	Sync2(L)	Gnd
9	ARP1(H)	ARP1	27	ARP1(L)	Gnd
10	CLK1(H)	CLK1	28	CLK1(L)	Gnd
11	ACP1(H)	ACP1	29	DIG6(H)	Dig6
12	DIG5(H)	DIG5	30	ACP1(L)	Gnd
13	CLK2(H)	CLK2	31	DIG6(L)	Gnd/Dig14
14	DIG5(L)	Gnd/Dig13	32	CLK2(L)	Gnd
15	ARP2(H)	ARP2	33	DIG8(H)	Dig8
16	DIG7(H)	Dig7	34	ARP2(L)	Gnd
17	ACP2(H)	ACP2	35	DIG8(L)	Gnd/Dig16
18	DIG7(L)	Gnd/Dig15	36	ACP2(L)	Gnd

## Osiris with RVP

Osiris is compatible with Curtiss-Wright's RVP product, which provides a capability for radar video distribution over LAN, plot extraction, target tracking and video recording. A single Osiris card can support the processing of dual-independent channels of radar video, which can be distributed to multiple display clients using RVP. A typical installation will feature RVP running on a VME or CompactPCI (cPCI) single board computer (SBC), with an Osiris PMC board serving as the radar interface. Alternatively, RVP can run on a PCI-based system with Osiris-PCI providing the radar input.

## Osiris Board Support Software

Osiris has a device driver and board support package that provides a C language programming interface to application developers. This board support library provides a well-documented interface to all functions of the board, including configuration and data transfers.

## Specifications

### Functional

- ◆ Digitisation and processing of radar video
- ◆ Up to 16 k samples per return
- ◆ Maximum output rate 50 MB/s per channel
- ◆ Internal test pattern generator
- ◆ Gain-and-offset-with-range compensation
- ◆ Time-stamped radar returns
- ◆ Onboard FPGA for processing
- ◆ Sample frequency up to 50 MHz
- ◆ Range and inter-return processing by highest-wins or lowest-wins

### Radar Video Inputs

- ◆ Two Analog video inputs (two active selected from four inputs for Osiris B):
- ◆ Differential, single-ended or high impedance
- ◆ -1.5 V to +6.5 V range
- ◆ 50 MHz sampling, 25 MHz bandwidth with programmable digital filtering
- ◆ Eight digital inputs, RS-422 or RS-423
- ◆ Clock input (optional)
- ◆ 75 Ohms termination (single-ended), 120 Ohms (differential), 1k Ohms (high impedance)
- ◆ ESD protection to 6.5KV

### Dual-sync (Trigger) Input

- ◆ Programmable delay from trigger to range zero
- ◆ Differential, single-ended or high impedance
- ◆ 75 Ohms termination (single-ended), 120 Ohms (differential), 1k Ohms (high impedance).
- ◆ 0 to +30V input (maximum power dissipation is 0.5 W on PMC card and 10 W on PCI card. For high-voltage sync inputs an external high-power terminating resistor may be required).



### **Turning Data**

- ◆ ACP/ARP
- ◆ ACP count: up to 16384.
- ◆ Differential, single-ended or high impedance
- ◆ 75 Ohms termination (single-ended), 120 Ohms (differential), 1k Ohms (high impedance)
- ◆ Minimum pulse width is 100 ns
- ◆ RADDs I and II formats (MIL-STD-751B)
- ◆ Synchro input supported on PCI variant of card with addition of synchro-adaption module
- ◆ For AN/UYQ-21, AN/UYA-4 and other serial and parallel formats, consult factory for further information

### **Radar Data Output**

- ◆ PCI interface to host processor
- ◆ 64-bit, 66 MHz PCI interface (32-bit interface on PCI version of card)

### **Connectors**

- ◆ 36 way MDR socket for all radar video, trigger and azimuth signals.
- ◆ Synchro input on PCI version of card from flying lead to separate connector.

### **Software, O/S and Host Support**

- ◆ Compatible with RVP for radar network distribution and target tracking
- ◆ Board support library available:
  - Windows®
  - Linux®/x86

### **Physical & Mechanical**

- ◆ Available as single PMC or half-length PCI module
- ◆ PMC version:
  - Dimensions: 74 x 155 mm IEEE P1386.1
  - Weight: 100 g
- ◆ PCI version
  - Dimensions: 174 x 106 mm
  - Weight: 100 g

### **Electrical**

- ◆ Power Consumption:
  - ◆ +3.3 V 700 mA
  - ◆ +5 V 200 mA
  - ◆ +12 V 30 mA
  - ◆ -12 V 80 mA
- ◆ Standard PCI v2.2 interface (33 or 66 MHz, 3.3 V or 5 V signaling)

### **Environmental**

Available in the following Curtiss-Wright environmental grades:

- ◆ Air-cooled Level 0
  - Operating temperature 0 to +50°C
  - Storage temperature -40 to +85°C
- ◆ Air-cooled Level 50 (conformally coated)
  - Operating temperature -20 to +65°C
  - Storage temperature -40 to +85°C

For further details please see the Curtiss-Wright Ruggedization Table at <http://www.cwembedded.com/0/0/208.html>



**Table 3: Configuration Options and Part Numbers**

Part Number	Description
SPCI-C616-0-0000	Osiris PCI Radar Interface card: Air-cooled, Level 0 specification.
SPCI-C616-0-0001	Osiris PCI Radar Interface card: Parallel azimuth version Air-cooled, Level 0 specification.
SPCI-C616-0-C000	Osiris PCI Radar Interface card: Air-cooled, Level 50 specification. Conformally coated
SPMC-C617-0-0000	Osiris PMC Radar Interface card: Air-cooled, Level 0 specification.
SPMC-C617-5-C000	Osiris PMC Radar Interface card: Air-cooled, Level 50 specification. Conformally coated
SPMC-C660-0-0000	Osiris-B PMC Radar Interface card: Four radar inputs Air-cooled, Level 0 specification.
DSW-C580-0-0401	Osiris board support library and driver for Windows and Linux/x86
CBL-C617-0-0500	Breakout cable from Osiris front-panel connector to 25-way D connector (for digital radar inputs) and 8x BNC (trigger, video, ACP and ARP for each of two channels). Length 1.2m.
SPCI-C616-0-020x	Osiris PCI Radar Interface card with synchro interface; consult factory for options

## Warranty

This product has a one year warranty.

## Contact Information

To find your appropriate sales representative:

Website: [www.cwembedded.com/sales](http://www.cwembedded.com/sales)

Email: [sales@cwembedded.com](mailto:sales@cwembedded.com)

## Technical Support

For technical support:

Website: [www.cwembedded.com/support1](http://www.cwembedded.com/support1)

Email: [support1@cwembedded.com](mailto:support1@cwembedded.com)

The information in this document is subject to change without notice and should not be construed as a commitment by Curtiss-Wright Controls Embedded Computing. While reasonable precautions have been taken, Curtiss-Wright assumes no responsibility for any errors that may appear in this document. All products shown or mentioned are trademarks or registered trademarks of their respective owners.