



PMC-724

Frame Grabber

UNITRONIX Pty Ltd

PO Box 486, Morisset NSW 2264

NSW: Tel: 61 2 4977 3511 Fax: 61 2 4977 3522

WA: Tel: 61 8 9455 2424 Fax: 61 8 9455 2458

unitsyd@unitronix.com.au www.unitronix.com.au

Features

- Optimized real-time video capture PMC
- High speed data transfer to a PCI-mapped memory
- Digital and Analog video capture
- LVDS interface supporting digital video capture (interlaced and non-interlaced)
- Four selectable analog video inputs including NTSC, PAL, RS-170 and S-Video
- Extensive flexibility through the onboard Field Programmable Gate Array (FPGA)
- Supported under VxWorks (Tornado 2) for PowerPC
- X11 Server and GUI independent software support
- PCI Rev 2.1 compliant, 32 bit, 33/66Mhz capable
- Available in a full range of ruggedization levels, both air and conduction cooled.



Overview

The PMC-724 mezzanine module is a ruggedized IEEE 1386.1 PMC Frame Grabber providing high-performance image capture capabilities. The PMC-724 Frame Grabber captures both analog and digital video input formats and supports high speed transfer of the captured images to system memory (e.g. basecard or other PCI-accessible memory). Applications such as target tracking and UAV image capture are ideally suited for the PMC-724 where analog or digital video data is gathered in realtime then transferred to a basecard (e.g. the VME-179, VME-181, Cornerstone (VME-712) or CHAMP-AV II) for processing.



The PMC-724 is supported by a complete software API which allows the developer to quickly develop a custom Frame Grabber application to meet their specific system needs. The flexibility provided by the PMC-724's onboard FPGA allows us to customize it to support non-standard digital video formats making the PMC-724 ideal for retrofit applications as well as new designs.

Functionally equivalent versions of the PMC-724 are available in a variety of ruggedization levels for use in environments from laboratories, to challenging ground, naval or avionics environments.

The PMC-724 leverages technology from our Insights graphics products, and as with all our Graphics products, supports industry standard hardware and software interfaces. The PMC-724 software support is also fully integrated with our X11 / OpenGL software products.

Video Input Capabilities

PMC-724 provides a variety of video capture capabilities. Either analog or digital video signals can be captured in real-time. The X11 extension Xv and PMC-724 native API provide programmatic control over the video input functions.

Captured video images can be stored in any PCI accessible memory or written directly to the Permedia 3 graphics memory on the Trinity 1, Trinity 2 or Cornerstone graphics products.

Analog Video Capture

The PMC-724 provides four (4) PAL/NTSC, RS-170 (single-ended) or two (2) S-Video inputs, any one of which can be selected for video capture at any given time.

Table 1: Analog Video Capture Modes

Resolution	Refresh Freq (Hz)	Color Depth (bits)
525 line (NTSC)	30	8,16,32, 16 bit YUV
625 line (PAL)	25	8,16,32, 16 bit YUV
RS-170A	30	8,16,32, 16 bit YUV
RS-170	30	monochrome
S-Video	30	8, 16, 32, 16 bit YUV

Digital Video Capture

The PMC-724 supports a five (5) pair LVDS digital video capture interface.

The LDVS interface is compatible with various video protocols including FlatLink and OpenLDI, single pixel, unbalanced mode. The LVDS capture is implemented through the FPGA and therefore allows different LVDS digital video protocols to be accommodated. Contact your local representative directly should you require this service.

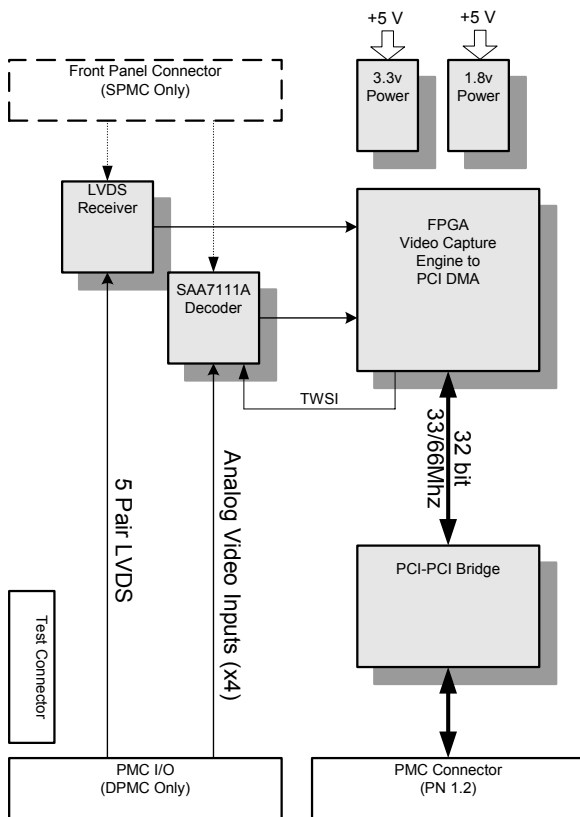

Figure 1: PMC-724 Frame Grabber Block Diagram

Table 2: Digital Video Capture Modes

Protocol	Color Depth (bits)	Interface	Interlaced	Non-Interlaced
Open LDI	8,16,24	LVDS	yes	yes
FlatLink	8,16,24	LVDS	yes	yes
RS-343*	8, 16, 24	LVDS	yes	n/a
RS-170*	8, 16 24	LVDS	yes	n/a

* Analog video formats could be converted (by customer's external circuitry) to an LVDS digital format for capture by the PMC-724. This interface is defined in the PMC-724 Interface Control Document (ICD).

Built-In-test (BIT)

BIT for the PMC-724 is provided by firmware routines within our Card level Diagnostics (CLD) package. CLD is part of the Foundation Firmware suite of firmware components delivered in the flash memory of our SBCs.

Software Support

The extensive software support for the PMC-724 allows the developer to design applications with ease. The PMC-724 software API allows the developer's application to:

- Control one or two PMC-724's from a single API
- Assign multiple DMA memory buffers (1 to 32) per PMC-724
- Modify the Hue, Saturation, Brightness and Contrast of the images being captured (analog only)
- Real-time start and stop capture of frames
- Capture a specific number of frames
- Set and get the basecard memory location for image transfer
- Set and get the video input mode
- Set and get the video resolution
- Set and get the color settings
- Set the debugging level
- Real-time application callback function triggered at end of field/frame
- Track (count) the number of frames captured

The Frame Grabber software allows for 2 modes of operation.

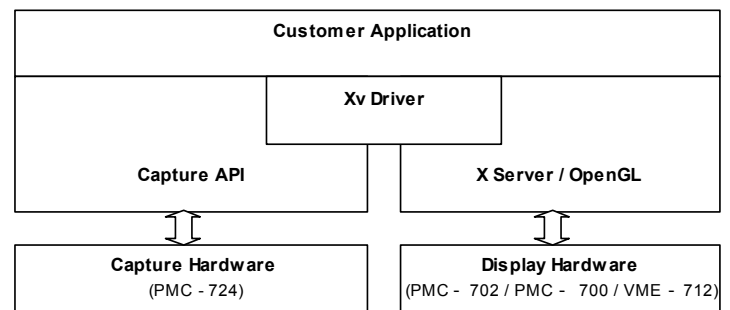

X11 / OpenGL Interface

The PMC-724 software is supported and fully integrated with our X11, Motif and OpenGL graphics software products (sold separately) under VxWorks Tornado 2 via the X11 Xv application.

Graphical User Interface (GUI) Independent

The software is also structured such that it can be used independently of any windowing system. The software development and build environments allow you to link the Frame Grabber software directly with the VxWorks kernel providing a GUI-independent application interface.

Both interfaces provide the ability to perform high-speed, real-time, DMA-based transfers to a PCI-mapped memory location. These interfaces will allow the developer to store the image in memory for later processing or write the captured image into Permedia 3 graphics memory (on the Trinity 1, Trinity 2, or Cornerstone cards) for display purposes.

In order to help accelerate development efforts, an example demonstration application is provided in 'C' source code and binary formats to allow the developer to more quickly develop a custom Frame Grabber application.

Supported development hosts include VxWorks Tornado 2 for MS Windows and Solaris. Runtime support is available for VxWorks Tornado 2 for PowerPC. The development software and maintenance service are sold separately from the PMC-724 hardware.



Flexibility

PMC-724 is available in various configurations to match the features, performance and ruggedization required for the target application. PMC-724 utilizes common hardware interface standards to the Trinity 2 (PMC-702) and Cornerstone (SVME/DMV-712) graphics products for seamless integration.

Support Cables

Air-cooled versions of the PMC-724 use the same support cable as the PMC-702 allowing for the cable to be used for both products.

Product Number	Card Style	Connector
CBL-702-000	SPMC Only	Front Panel

Table 3: *Specifications*

RUGGEDIZATION LEVELS*		
SPMC card	Available in levels 0 and 100	
DPMC card	Available in levels 100 and 200	
POWER REQUIREMENTS		
5 V	350mA (typical), 500mA (maximum)	
DIMENSIONS		
	Size	Weight
SPMC card	Per IEEE 1386.1	< 131 g (0.29 lb)
DPMC card	Per IEEE 1386.1 (ANSI/VITA 20-2001)	< 101 g (< 0.23 lb)

*Refer to Ruggedization Guidelines for more details.



Contact Information

To find your appropriate sales representative, please visit:

Website: www.cwembedded.com/sales or

Email: sales@cwembedded.com

For technical support, please visit:

Website: www.cwembedded.com/support1

Email: support1@cwembedded.com

The information in this document is subject to change without notice and should not be construed as a commitment by Curtiss-Wright Controls Inc., Embedded Computing (CWCEC) group. While reasonable precautions have been taken, CWCEC assumes no responsibility for any errors that may appear in this document. All products shown or mentioned are trademarks or registered trademarks of their respective owners.

© Curtiss-Wright Controls Embedded Computing, Ottawa.