

PPC-1571

15" LCD Ultra-slim Low-power Fanless Panel PC with VGA/4USB/5COM/LAN/1394b



UNITRONIX Pty Ltd

PO Box 486, Morisset NSW 2264
 NSW: Tel: 61 2 4977 3511 Fax: 61 2 4977 3522
 WA: Tel: 61 8 9455 2424 Fax: 61 8 9455 2458
 unitsyd@unitronix.com.au www.unitronix.com.au

Dimensions

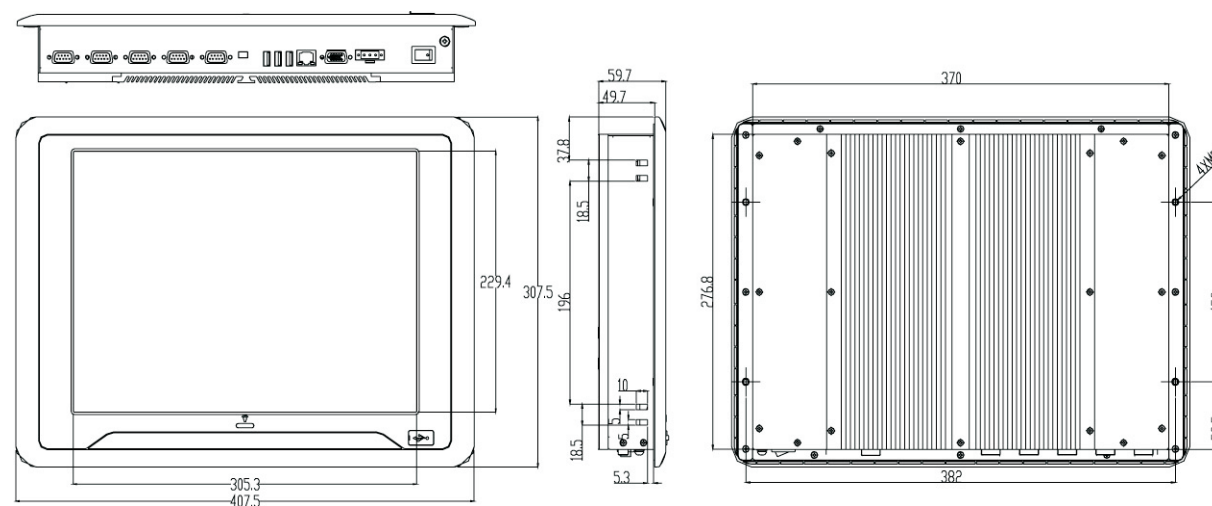

1
PICMG



Features

- 15" ultra-slim color TFT LCD, touch screen available (optional)
- Intel® Atom™ N270
- Onboard 1GB DDRII memory
- Supports 4 x USB2.0, 5 x COM, 1 x LAN, 1 x VGA, 1 x 1394b port

2
EPIC/EBX
/xTX

Specifications

Display Features

Display Screen	15" color TFTLCD
Display Chipset	Intel® 945GSE integrated graphics acceleration controller
Dual Display	VGA+18-Bit LVDS
Resolution	XGA(1024 x 768)
Brightness	350 cd/m2
Contrast ratio	400:1
Touch Screen	5-wire resistive touch screen with RS-232 port

System

SBC Model	MB-PPC-1571
Processor	Intel® Atom™ N270
Chipset	Intel® 945GSE + ICH7M
Memory	Onboard 1G DDRII memory
Hardware Monitor	CPU temperature monitor, voltage monitor, and watchdog timer, etc.
Watchdog Timer	1~255 sec./min. timer system reset/interrupt, setup by software
Expansion Interface	N/A
Storage	1 x 160G 2.5" SATA hard disk, Support 1 x Compact Flash Socket Type I/II

Ethernet

Chipset	RTL811D
Speed	1 x 10/100M/1000M
Connector	RJ45

I/O Interface

USB	4 x USB2.0
Serial Port	4 x RS-232 and 1 x RSS-232/422/485 (COM5 port)
Parallel Port	N/A
KB/MS	1 x VGA
VGA	N/A
Audio	N/A

Mechanical and Environmental

Dimensions	407.5 mm (L) x 307.5 mm (W) x 59.7 mm (H)
Weight	6.7kg/8.12kg
IP Level (front panel)	IP65 (optional)
Reliability	MTBF ≥ 50000h;
Safety	GB4943-compliant
Operating Temperature	0°C~50°C
Storage Temperature	-20°C~60°C
Operating Humidity	10%~95%(non-condensing)

Power

Power Supply	24V DC(±5% redundant) Input
--------------	-----------------------------

Operating System

Windows OS	Windows2000/Windows XP Sp3
------------	----------------------------

Test

Vibration	5~17Hz/1.0mm amplitude, 17-200Hz/1.0g acceleration
Shock	10g acceleration, 11ms duration
EMC/EMI	GB9254-2008 class A

Optional Accessories

Part Number	Name	Description	Qty.
2330-001101	Terminal block/RoHS	3-pin/pitch: 5.08mm/green/with screw/female connector MC101-50803	1
2192-012781	CD/Chinese and English/protective film/RoHS	PPC-1571	1

Ordering Information

Part Number	Model Number	Description
0010-030751	PPC-1571	15" LCD ultra-slim low-power fanless panel PC with VGA/4USB/5COM/LAN/1394b

1
PICMG

2
EPIC/EBX
/xTX

3
BoxPC

4
HMI