



Data Sheet

CSW1

VXS Zero Latency, Reconfigurable, Crossbar Switch

UNITRONIX Pty Ltd

PO Box 486, Morisset NSW 2264

NSW: Tel: 61 2 4977 3511 Fax: 61 2 4977 3522

WA: Tel: 61 8 9455 2424 Fax: 61 8 9455 2458

unitsyd@unitronix.com.au www.unitronix.com.au

Applications

- ◆ ELINT, SIGINT, COMINT
- ◆ Surveillance
- ◆ RADAR and SONAR
- ◆ Real-time Imaging

Features

- ◆ Interconnects any VXS backplane link
- ◆ 56 1x (14 4x) backplane data links, up to 3.2Gbps per link
- ◆ Up to 12 front panel fibre optic transceivers
- ◆ Supports hardware data multicast
- ◆ Can run multiple protocols concurrently at different speeds
- ◆ Air or conduction cooled rugged versions

Benefits

- ◆ Simplifies the configuration of VXS systems
- ◆ Connects any front panel transceiver to any VXS link
- ◆ Enables the use of standard VXS backplanes to create a custom configuration
- ◆ Ideal for real-time system solutions

Overview

The CSW1 is a VXS switch slot compatible card that enables standard backplanes to be configured with any topology. At its heart, is a cross-bar circuit switch that enables any high-speed serial data link to be linked to any other high-speed serial data link, independent of protocol. These links can be VXS backplane connections or front panel (copper or fiber-optic) transceiver I/O. Other modes, such as multicast, are also supported.

VXS Backplane Configuration

The CSW1 supports up to 56 VXS 1x (backplane) links (or 14 4x) which can be configured for any routing topology. The actual routing is established using static circuit switches. These link together the VXS payload connections routed by the backplane to the switch slot. The combination of the CSW1 and a standard backplane is to effectively provide a custom backplane routing scheme using off-the-shelf products. Each VXS payload card supports up to 2 4x (8 1x) links, so depending on the VXS backplane employed, the CSW1 can be used to fully connect up to 7 payload cards with dual 4x links or 14 payload cards with a single 4x link. Thus the CSW1 can support systems ranging from 2 to 14 VXS payload cards using 4x links.

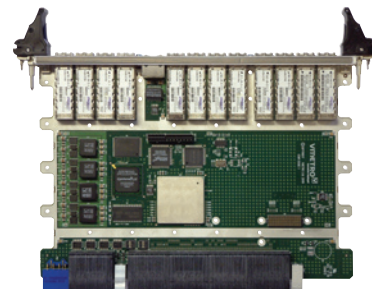
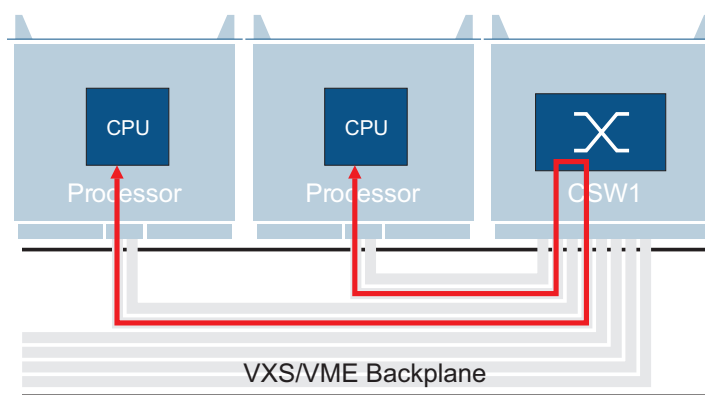

Figure 1: Inter-linked VXS Payload Cards



Learn More

Web / sales.cwembedded.com

Email / sales@curtisswright.com

**CURTISS
WRIGHT** Controls
Embedded Computing

Innovation In Motion.
cwembedded.com



Front Panel Data I/O

In addition to backplane data link routing, the CSW1 supports front panel serial I/O ports with up to 12 transceiver channels. The transceivers can operate at any speed up to 3.2Gbps depending on the specific transceiver type. These channels can be routed to any of the VXS communications channels for convenient data input/output from sensor arrays or data recorders.

Figure 2: CSW1 can be used to inter-link VXS systems

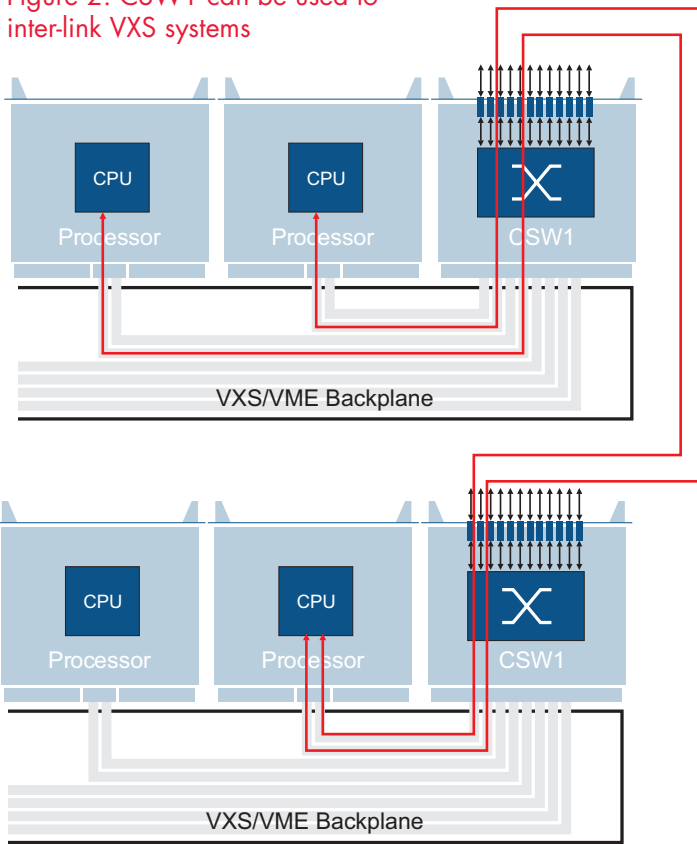

The CSW1 can be provided with any mix of front panel I/O transceivers. These can include single-mode (for greater distance) or multi-mode and 'pig-tail' fiber connections suitable for greater ruggedization.

The front panel transceivers can be used to connect racks and systems together in the same way as the CSW1 can interconnect the VXS payload boards. The only difference is that the signals are routed via 2 circuit switches, but because these have low latency, there is very little impact on overall system performance. This useful mechanism allows for system expansion.

Figure 3: High-speed Serial Communications via the Front Panel

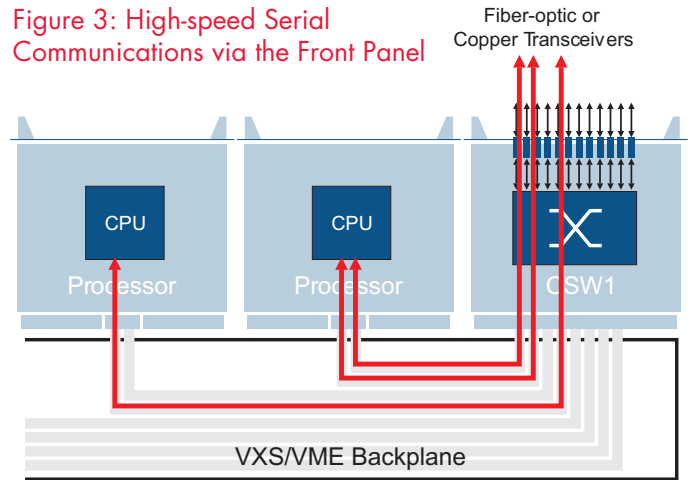

Hardware Data Multicast

Often, in real-time applications, the ability to multicast data is important. Traditionally this has imposed a large overhead on a data processor within the system, but the CSW1 overcomes this by being able to multicast data streams over several channels at once in hardware. This feature allows several processor blocks to perform processing on common data in parallel. An example of this is real-time imaging processing where several processors can search for different features within a video input stream without the need to set up data pipelines. This improves system latency and response times. The universal nature of the CSW1 means that the data streams to be multicast can come from any source - within the system from a VXS board or externally. Multicast messages are also useful for synchronizing the system operation.

Figure 4: Data Multicast from Internal Source

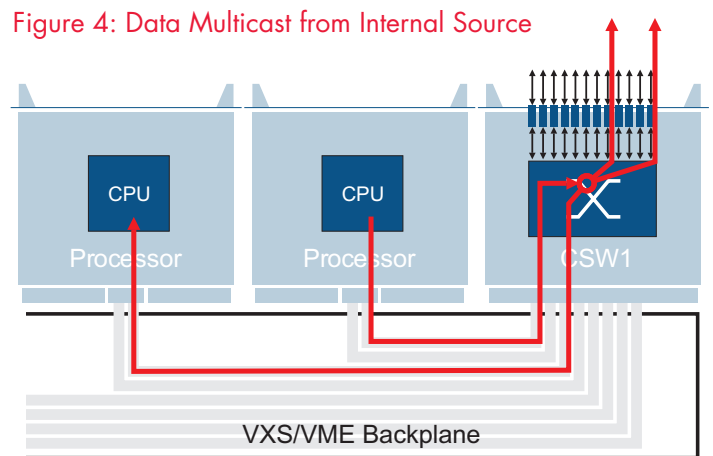
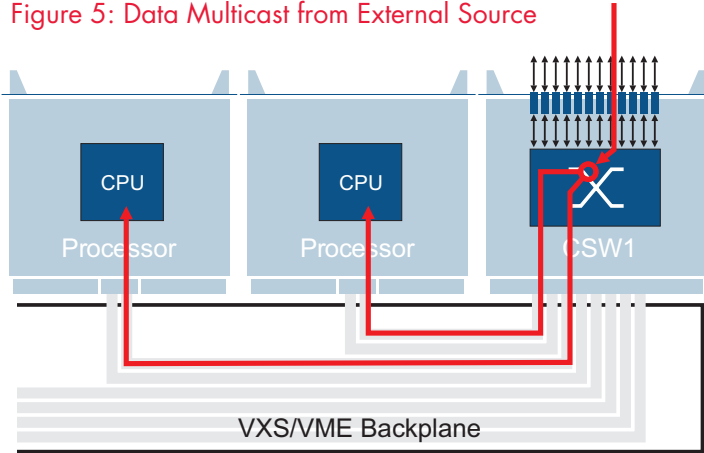



Figure 5: Data Multicast from External Source



Since the CSW1 can move data to more than one place at the same time, data recorder applications can benefit from data multicast; while the data stream is routed to the rest of the system, a duplicate stream can be sent to the recorder sub-system. Because this happens in parallel, in hardware, there would be no impact on the processor stream and therefore system performance.

Input/Output to Processor Cards

In addition to simply interconnecting processing elements within a VXS system, the CSW1 can be used to establish and route high speed serial communications between peripherals like VXS based I/O cards and other elements within a VXS system.

Figure 6: Directing External I/O using CSW1

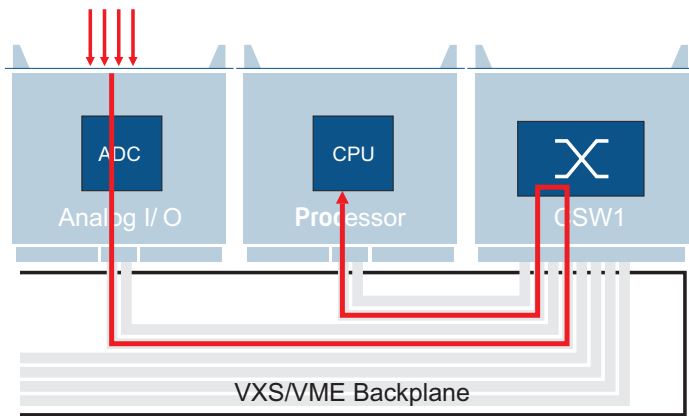

Monitoring/Debugging

Data multicast can be useful for debugging systems because the multicast mechanism can be used to monitor the traffic across any link without interfering with it in any way. Thus, using a simple multi-cast mode, provides a straightforward way to 'tap' into the monitored signals.

Mixed Data Link Speeds

The CSW1 does not need to know about data link speeds because of its wide bandwidth I/O. Some data channels can operate at one frequency while others operate at a different frequency. As long as the serial end-points are compatible, the CSW1 can be relied upon to link the data streams. This is particularly useful for using sensor interfaces with different data rates and protocols.

Routing Configuration

The CSW1's routing topology is set up via an on-board microcontroller. The user interface is provided through an HTML browser front end running on a remote computer and connected to the CSW1's configuration controller via an Ethernet port. This provides a convenient interface to set-up and reconfigure the channel routing at any time by using images stored in the CSW1's FLASH memory. New configurations can be downloaded or set up 'manually' through the user interface. The user configuration Ethernet port is provided through the CSW1's front panel.

Rugged Build Options

The CSW1 is available in a number of environmental build options ranging from commercial air cooled to extended temperature rugged air cooled to rugged conduction cooled. This allows the CSW1 to be used alongside other Curtiss-Wright products to provide effective solutions for a wide variety of applications.

Contact Curtiss-Wright for the availability of CSW1 cards fitted with front panel transceivers to match your requirement.



Figure 7: The CSW1 can be used for complex systems; different data speeds, different channel widths, external communications and more.

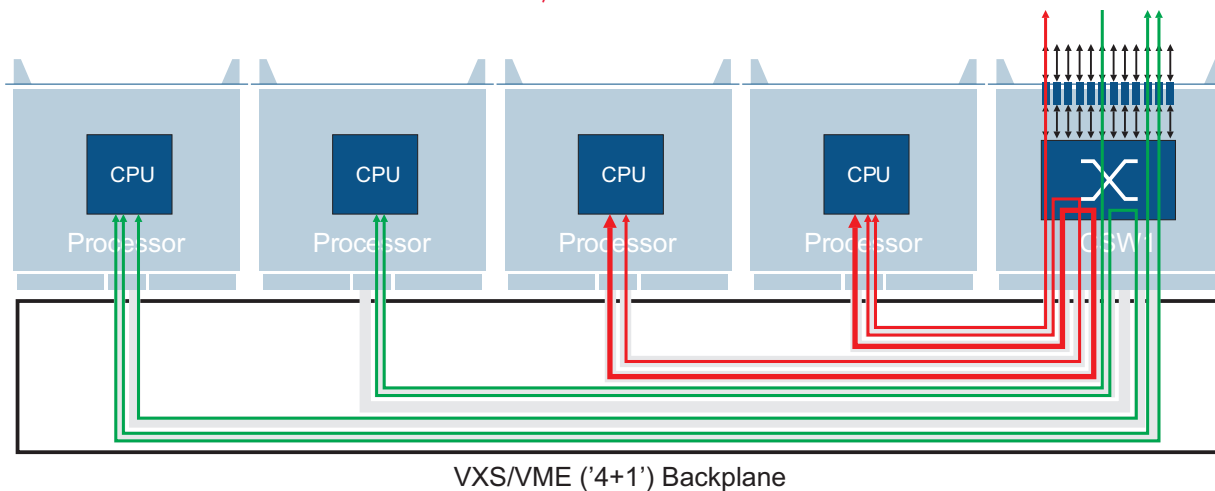

Figure 8: CSW1 Block Diagram

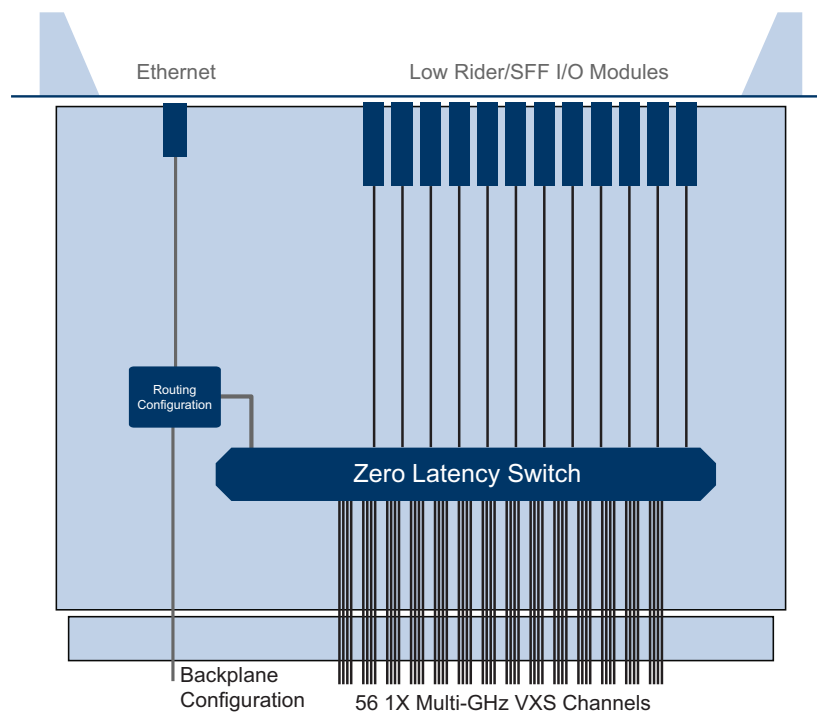



Table 1: Specifications

Switch	
Total number of channels	72
Channel bandwidth	0 - 3.2Gbps
Number of VXS switch connections	56 (7 VXS payload slots with 8 links per slot)
Front Panel Transceivers	
Number	0 - 12 (air-cooled) 0 - 10 (conduction-cooled)
Frequency range	0 - 3.2Gbps (transceiver dependant)
Transceiver format	Module dependant using 'low rider', 'rough rider' or SFF format. (contact Curtiss-Wright for options)
Configuration Processor	
Connection	Front panel 10/100M Ethernet RJ45 Connector
Configuration images	Stored in in FLASH or downloaded via Ethernet port

Board Format	
VXS Switch	VITA 41
Power	
Total	25W + 1W per front panel transceiver
Environment (Commercial)	
Temperature (operating)	0 to +50°C
Temperature (storage)	-40 to +70°C
Environment (air-cooled, extended temp, shock and vibration)	
TBA	
Environment (conduction-cooled, extended temp, shock and vibration)	
TBA	

Warranty

This product has a one year warranty.

Contact Information

To find your appropriate sales representative, please visit:

Website: www.cwembedded.com/sales

Email: sales@cwembedded.com

For technical support, please visit:

Website: www.cwembedded.com/support1

Email: support1@cwembedded.com

The information in this document is subject to change without notice and should not be construed as a commitment by Curtiss-Wright Controls Inc., Embedded Computing (CWCEC) group. While reasonable precautions have been taken, CWCEC assumes no responsibility for any errors that may appear in this document. All products shown or mentioned are trademarks or registered trademarks of their respective owners.