



Data Sheet

PMC-650

8-Port Gigabit Ethernet Switch PMC



UNITRONIX Pty Ltd

PO Box 486, Morisset NSW 2264

NSW: Tel: 61 2 4977 3511 Fax: 61 2 4977 3522

WA: Tel: 61 8 9455 2424 Fax: 61 8 9455 2458

unitsyd@unitronix.com.au www.unitronix.com.au



Features

- ◆ 8-Port Gigabit Ethernet switch
- ◆ Line-speed, Layer-2 switching, unmanaged
- ◆ Supports 10/100/1000 Base-T on all ports
- ◆ Supports jumbo packets up to 9728 bytes
- ◆ IEEE 802.3 compliant
- ◆ All ports on Pn4 backplane I/O connector
- ◆ One activity LED per port
- ◆ No software required
- ◆ Range of air and conduction-cooled ruggedization levels available

Overview

The PMC-650 is an 8-Port Gigabit Ethernet Switch packaged in the industry-standard PMC form factor. The PMC-650 is designed to support "in-chassis" networks with unmanaged Layer-2 switching capabilities. The PMC-650 is a part of a family of Gigabit Ethernet Switching/Routing products from Curtiss-Wright that can scale from simple unmanaged small port count switches to fully managed larger port count routers. The PMC-650 is designed for rugged applications with backplane I/O and is offered in a full range of ruggedized air-cooled and conduction-cooled versions.

Ethernet Switching

The PMC-650 implements Ethernet switching functions via a Broadcom BCM5388 8-port switch. All ports support 10/100/1000 Base-T with auto-negotiation. The PMC-650 implements Layer-2 switching with full wire-speed performance on all ports. The PMC also offers a 4096-entry ARL MAC address table with automatic learning and advanced flow-control and head-of-line blocking prevention.

The PMC-650 uses a store and forward architecture, with packet latencies ranging from approximately 2.5 to 15 usec (on average the typical latencies are less than 3 usec). Jumbo frames are supported on 1000 Base-T enabled ports. It is recommended that only two ports make use of jumbo frames. The PMC-650 is intended for use in network topologies that do not include redundant paths between nodes. The support of such complex topologies requires the use of spanning tree protocols and loop detection which are features of Curtiss-Wright managed products such as the VME-680 SwitchBlade or VME/VPX-682 FireBlade.

The PMC-650 is a slave peripheral device which does not feature any Built-In-Test (BIT) software.

Optional Configurations

The Broadcom BCM5388 switch provides a number of programmable features which are configured at power-up by an on-board EEPROM. The configuration is set at the factory and is not user programmable. These features include port trunking/aggregation, disabling auto-negotiation, port mirroring and broadcast storm filtering.

Learn More

Web / sales.cwembedded.com

Email / sales@curtisswright.com

**CURTISS
WRIGHT** Controls
Embedded Computing

Innovation In Motion.
cwembedded.com



Port trunking/aggregation allows more than one port to be grouped together between two devices, increasing the effective bandwidth between them. Disabling auto-negotiation permits, on an individual basis, to force the speed of a port to a particular setting. Port mirroring configures one port to monitor all other ports on the switch. This mode allows for back pressure or flow control to tell different ports to slow down when the monitor port is busy or experiencing very high levels of traffic. Broadcast storm filtering monitors and constrains the level of broadcast traffic on each port. Consult the factory for availability of these options.

Connectivity

The PMC-650 routes all 8-ports through the P14 connector. There are no front panel connectors. Each port has an associated status/activity LED. For reliable operation, it is recommended that the host card implement impedance-controlled differential tracking of the PMC I/O signals. Most Curtiss-Wright PMC-enabled SBCs and multi-processor boards can support the PMC-650. Please contact a Curtiss-Wright representative for further information.

The PMC-650 only connects to the PCI bus to obtain power and ground. It has no effect on the operation of the host PCI bus. No software driver is needed.

Figure 1: PMC-650 Block Diagram

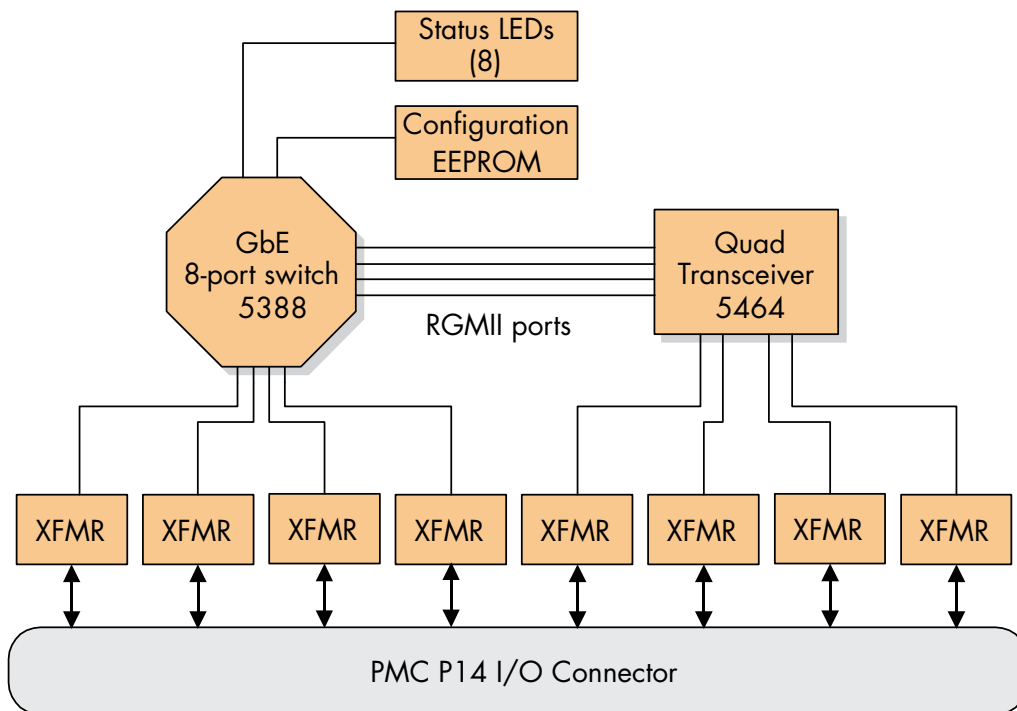



Part Number

Ordering information for the PMC-650 is provided below.

SPMC/DPMC-650-ABC

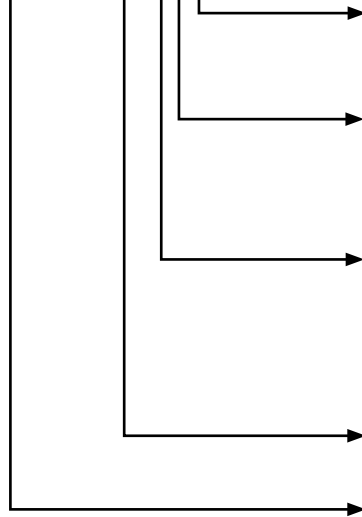

Ports:

8 = 8 x 10/100/1000 GbE ports

TBD:

0 = TBD

(not required at this time so set to 0)

Ruggedization level:

0 = L0

1 = L100

2 = L200

Model number: 650

Cooling method:

SPMC: Convection (Air) cooled PMC

DPMC: Conduction cooled PMC

Table 1: Power requirements

Typical 10 Base-T operation	5V @ 0.2A 3.3V @ 1.2A
Typical 1000 Base-T operation	5V @ 0.925A 3.3V @ 2.2A

Note: Maximum operation: is 20% higher than typical numbers

Table 2: Dimension and weight

Option	Dimension	Weight
Air-cooled	per IEEE 1386.1	< 101 grams
Conduction-cooled	per IEEE 1386.1 (VITA 20-199x)	< 70 grams

Note: Air-cooled cards available in level 100.

* Conduction cooled cards available in level 100 and level 200.

** Refer to Ruggedization Guidelines fact sheet for more information.



Warranty

This product has a one year warranty.

Contact Information

To find your appropriate sales representative, please visit:

Website: www.cwembedded.com/sales

Email: sales@cwembedded.com

For technical support, please visit:

Website: www.cwembedded.com/support1

Email: support1@cwembedded.com

The information in this document is subject to change without notice and should not be construed as a commitment by Curtiss-Wright Controls Inc., Embedded Computing (CWCEC) group. While reasonable precautions have been taken, CWCEC assumes no responsibility for any errors that may appear in this document. All products shown or mentioned are trademarks or registered trademarks of their respective owners.