



Data Sheet

VPX3-683 FireBlade

24x1GbE + 2x10GbE Gigabit Ethernet Switch/Router

UNITRONIX Pty Ltd

PO Box 486, Morisset NSW 2264
NSW: Tel: 61 2 4977 3511 Fax: 61 2 4977 3522
WA: Tel: 61 8 9455 2424 Fax: 61 8 9455 2458
unitsyd@unitronix.com.au www.unitronix.com.au



Features

- ◆ Managed intelligent multi-layer (Layer 2/3) Gigabit Ethernet (GbE) switch, designed for highest port density in a 3U VPX form factor
- ◆ Supports complete range of convection and conduction-cooled formats (IEEE 1101.1, IEEE 1101.2)
- ◆ Data/Control/Management plane designed with Broadcom® StrataXGS® III switch chip with up to 24 wire-speed 10/100/1000Mbps (SerDes GbE) non-blocking, auto-negotiating ports
- ◆ Up to two 10GbE XAUI interfaces for high-speed backbones
- ◆ Control and management functionality designed using a Freescale Power Architecture™ MPC8245 integrated system controller with 64MB SDRAM, 4MB boot FLASH, 128MB FLASH File System Disk
- ◆ Enhanced security with ICSA certified firewall that protects against evasive attacks
- ◆ Supports both in-band management through any of the 24-ports, and out-of-band management through a serial EIA-232 interface
- ◆ Field upgradable through a serial EIA-232 interface or a 10/100BaseTX debug Ethernet interface
- ◆ Fully integrated Layer 2 switching, Layer 3 routing, Quality of Service (QoS), IP multicast, security and network management
- ◆ Intuitive "Industry Standard" Command Line Interface (CLI), web interface, SNMP interface and Telnet access for easy configuration and network management

- ◆ Rear Transition Module (RTM) with up to 24 SFPs that can support copper or optical connections, Infiniband cabling to support the two 10GbE XAUI interfaces, one 10/100 debug port, two EIA-232 serial interfaces (one for IPMI, the other for out of band switch management) for easy network setup
- ◆ Front panel LED status indicator provides per port link speed (10, 100, 1000Mbps or 10Gbps) and per-port link activity (receive or transmit)
- ◆ Fits in a single 3U VPX VITA 46 switch slot, OpenVPX/VITA 65 compliant, 2LM VITA 48 support

Overview

Enabling the vision of Net-centric operations and extending the reach of transformational networks, the VPX3-683 Fireblade is a GbE multi-layer switch that is ideally suited for building Intra-Platform Networks (IPNs) for air, land, and sea vehicles or ground stations. VPX3-683 Fireblade enables fast, reliable forwarding (switching and routing) of control and data packets with up to 24 wire-speed 10/100/1000Mbps interfaces and up to two 10Gbps uplinks that can be used to connect multiple chassis, cards, or even processors within platform networks.

Using star, dual star, mesh and hybrid network topologies, the VPX3-683 Fireblade provides a flexible cost effective solution that can be used to architect reliable 1 or 10GbE communications infrastructure for current and future networked platforms. Redundancy and fail-over can be implemented using dual star and mesh networks while

Learn More

Web / sales.cwembedded.com

Email / sales@cwembedded.com

ABOVE & BEYOND

**CURTISS
WRIGHT** Controls
Embedded Computing
cwembedded.com



Figure 1: VPX3-683 Fireblade Hardware Block Diagram

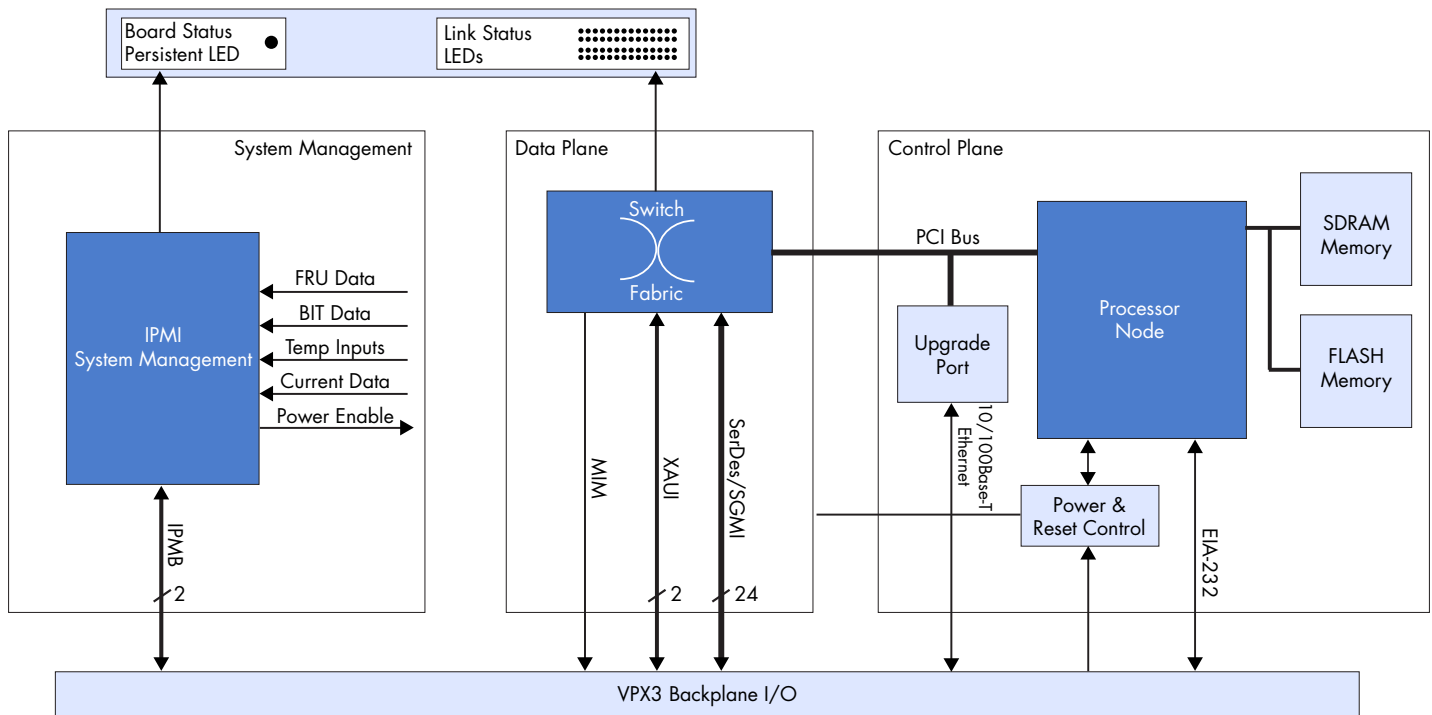

investment dollars can be retained by implementing hybrid network topologies that coexist with legacy and/or next generation interconnection strategies. Ready to deploy, the Curtiss-Wright Controls Embedded Computing VPX3-683 Fireblade allows systems integrators to reduce development costs and Time-to-Market (TTM) by simply plugging the VPX3-683 Fireblade into their 3U VPX chassis, connecting the appropriate Ethernet ports, and focusing on the optimal partitioning and segmentation of their application's network.

Designed for Maximum Performance

Allowing system integrators to develop and deploy switch-fabric based architectures today, the VPX3-683 Fireblade provides a completely integrated and unified management, control, and data plane solution for wire-speed performance of switched GbE traffic. Whether it is small, medium or larger IPNs, the VPX3-683 Fireblade provides a dense port combination of 24GbE SerDes ports that can be scaled down to lower port counts by disabling unused ports to save power.

The VPX3-683 Fireblade is comprised of a single basecard (Figure 1) with 24x1GbE and 2x10GbE interfaces routed to the backplane. An RTM is used to configure the GbE ports

a copper 10/100/1000BaseT, or as optical 1000BaseSX. Table 1 lists the various port types supported by the VPX3-683 Fireblade.

The VPX3-683 Fireblade can be complimented with an optional VPX3-215 Carrier with a PMC-110 CryptoNet Security module to create an advanced 2-slot Information Assurance (IA) solution, a RTM for easy RJ45 connectivity in the lab through the SFPs, and an LED front panel indicator for port status and activity.

Based on the industry leading Broadcom StrataXGS III multi-layer switch, the VPX3-683 Fireblade is capable of providing up to 24x 10/100/1000Mbps Ethernet ports with 64 million packets/second (line rate) aggregate switching capacity. The key features at the core of each Broadcom StrataXGS III that facilitate low latency wire-speed performance including a large high-speed fully integrated on-chip packet buffer memory, fast filter processors (FFP) per port, and advanced packet flow control capability per port. The two 10GbE XAUI ports can be used to stack routers to enable higher port counts, or they can be used to create high-speed 10GbE backbones.



Table 1: Port Type Specification

Port Type	Specification
10Base-T	<ul style="list-style-type: none"> • 802.3 standard • Automatic (MDI/MDIX) crossover • EIA Category 3, 4, or 5 unshielded twisted pair cabling • Maximum of 100 meters per segment length
100Base-Tx	<ul style="list-style-type: none"> • 802.3u standard • Automatic (MDI/MDIX) crossover • EIA Category 5 unshielded twisted pair cabling • Maximum of 100 meters per segment length
1000Base-T	<ul style="list-style-type: none"> • 802.3ab standard • Automatic (MDI/MDIX) crossover • EIA Category 5E unshielded twisted pair cabling • Maximum of 100 meters per segment length
1000Base-SX	<ul style="list-style-type: none"> • Front panel LC connectors or flexible pigtailed with LC terminations that can be routed to the back • Full duplex or simplex optics with separate Tx/Rx interfaces • Multi-mode support • Core/cladding: 62.5/125 or 50/125 • IEEE 802.3z
10GbE XAUI	<ul style="list-style-type: none"> • Signaling supports 10GBASE-CX4 • IEEE 802.3ae

Advanced Security

The VPX3-683 Fireblade can also be configured as a Unified Threat Management (UTM) router that is capable of strong perimeter defense through an ICSA certified firewall. This is achieved with a VPX3-215 Carrier card with a PMC-110 CryptoNet in an adjacent slot. This optional security solution provides an industrial strength statefull firewall that can protect against multiple evasive attacks. VPX3-683 Fireblade security features include:

- ◆ Statefull firewall (ICSA certified)
- ◆ Access control list (ACL) filtering
- ◆ Network Address Translation (NAT)
- ◆ Encryption/Decryption/Authentication
- ◆ Key generation/management
- ◆ Enables VPN with secure tunneling (IPSec/L2TP)

The PMC-110 CryptoNet and VPX3-215 combination in the adjacent 3U VPX slot can be connected to the VPX3-683 Fireblade with one of its GbE ports while a second GbE port from the PMC-110 can interface to the public network (WAN port).

Managed Switches

Managed versions of the VPX3-683 Fireblade are available. The managed version is a L2/L3 router with complete managed L2/L3 software, Quality of Service (QoS), IP multi-casting, and basic security. Management interfaces include "industry standard" CLI, SNMP, and web for easy configuration and network management. (Refer to Table 2 for Management Interfaces and Connection Strategies.)

Table 2: Management Interfaces and Connection Strategies

Interface	Connection	Client
CLI	<ul style="list-style-type: none"> • EIA-232/485 • Any in-band • Ethernet port 	Terminal Program Telnet
Web	<ul style="list-style-type: none"> • Any in-band • Ethernet port 	Web Browser
Network Management Station (NMS)	<ul style="list-style-type: none"> • Any in-band • Ethernet port 	Standard off the shelf NMS Software

Complete Integrated Software Solution

Managed versions of the VPX3-683 Fireblade provide extensive pre-integrated software that runs on its processor. Major software components include the full suite of Layer 2/3 software protocols required for intelligent switching and routing of IP packets (Figure 3 and Figure 4). Curtiss-Wright Controls also provides extra software features such as declassification, and Built-in Tests (BIT). BIT tests include Power BIT (PBIT), Continuous BIT (CBIT), and Initiated BIT (IBIT). Declassification is a utility that erases the non-essential contents in the FLASH File System (disk on chip). This process deletes the routing tables, filters and purges the switch of Ethernet packets and restores default configuration files from FLASH. This provides an extra layer of memory protection, and the ability to recover default information in the event of corruption.

Accessories

For building networks in the lab environment, Curtiss-Wright Controls provides a VPX3-683 Fireblade RTM that plugs into the backside of the VPX backplane and provides up to 24-ports of Small form factor Pluggable (SFP) interfaces that can enable copper ports, optical ports or a combination. Also provided on the RTM is a 10/100 deug port, two EIA-232 serial interfaces and 2-ports of 10GbE connectivity using Infiniband cabling. An LED front panel indicator is also included in all air-cooled versions of the VPX3-683 Fireblade cards.



Table 3: Overall Feature Specifications

Feature	Specification
Number of Ports	24 1GbE ports plus 2 10GbE ports
Out of Band Ports	<ul style="list-style-type: none"> • 10/100 Base-TX Ethernet interface for software update • EIA-232 Serial Switch Management Interface • Redundant IPMB I2C System Management Interfaces • JTAG support
Form Factor	<ul style="list-style-type: none"> • Designed specifically for rugged convection and conduction-cooled applications compliant to IEEE 1101.1 and IEEE 1101.2 • 3U slot width: <ul style="list-style-type: none"> – 0.8" slot pitch (variants without 2LM covers) as per VITA 46.0 – 0.85" slot pitch (variants with 2LM covers) as per VITA 48 specification
Throughput	64 million packets/second aggregate switching capacity (24 port version)
Capacity	<ul style="list-style-type: none"> • Packet Buffer 0.75MByte pool • Support for Jumbo packets up to 9KBytes • Up to 8K Layer 2 MAC addresses • Up to 1K Layer 3 IPv6 routes • 4K Virtual LANs supported • 1K Layer 2 Multicast groups • Content Aware Processor
Layer 2 Features	<ul style="list-style-type: none"> • Loop free, Transparent Bridging • Rapid Spanning Tree Protocol (RSTP) • Multiple Spanning Tree Protocol (MSTP) • VLAN Routing and Support • LAN information passing via GARP • VLAN registration passing via GVRP • Propagation of Multicast registration via GMRP • Forwarding Multicast traffic using IGMP Snooping • Increased Bandwidth and load sharing with Link Aggregation • Support for Port Mirroring • Support for Rate Limiting on each port
Layer 3 Features	<ul style="list-style-type: none"> • Unicast routing protocols like RIP, BGP & OSPF • Inter VLAN routing • Quality of Service QoS, in the form of Differential services • Supports both: <ul style="list-style-type: none"> – Differential Services Code Point DSCP mapping – Per Hop behavior • Multicast route computation using PIM & DVMRP <ul style="list-style-type: none"> – SM - sparse mode – DM - dense mode • Redundancy and Load Sharing through VRRP

Feature	Specification
General Features	<ul style="list-style-type: none"> • Support for DHCP Server / BOOTP server • Switch Configuration Save and Restore • Log file download via TFTP • Management of Switch through <ul style="list-style-type: none"> – SNMP – WebNM – CLI • Secure management interfaces through secure http (SSL) and secure shell (SSH) • RMON System probe for groups: 1 (Statistics), 2 (History), 3 (Alarm), and 9 (Events) • Power On Built-in Self Test

Table 4: Summary of Hardware Specifications

Feature	Description
Multi-layer switch	Broadcom StrataXGS III 563xx series
Management/Control Processor	MPC8245 PowerPC™
Memory	64Mbyte SDRAM, 4Mbyte boot FLASH, 128MB FLASH File System Disk
1 Gigabit Ethernet Ports	Up to 24
10 Gigabit Ethernet Ports	Up to 2
Serial Ports	Up to 2 EIA-232
Debug Ports	1 Ethernet port, 1 JTAG connector
Reset Switch	On RTM or via backplane
LEDS	Status an activity for each port
Power	+5V: Maximum Power required from + 5V Supply: 20W Voltage Tolerance on + 5V Supply: <ul style="list-style-type: none"> • 4.875 to 5.25V Tolerance • Less than 50mV Peak to Peak noise 3.3V_AUX Power <ul style="list-style-type: none"> • 3.3W Voltage Tolerance <ul style="list-style-type: none"> • 3.135V to 3.465V tolerance, less than 50mV Peak to Peak Noise VBAT: This power is bussed to all slots and can be provided by chassis or by the VPX3-683 RTM Power: <1.5µWatts Voltage Tolerance: 2.55V to 3.5V
Form Factor	3U VPX
Environmental	Convection or Conduction-cooled (AC0, AC100, CC200, CC300 with 2LM see Curtiss-Wright Controls ruggedization tables)

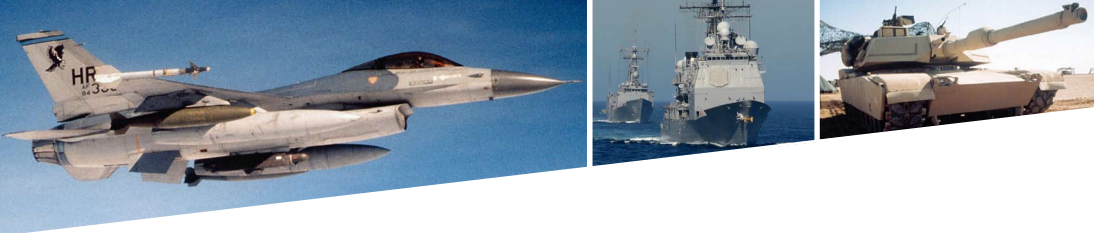

Table 5: Summary of Software Specifications*

Feature	Standard
MIB Support	
MIB II	RFC 1213
MIB II for SNMPv2c	RFC 1907, 3418
SNMP Community MIB	RFC 3548
SNMP Message Processing and Dispatching MIB	RFC 3412
SNMP Notification MIB	RFC 3413
SNMP Target MIB	RFC 3413
SNMP User Based Security Model MIB	RFC 3414
SNMP View Based Access Control MIB	RFC 3415
Interface group MIB	RFC 2233
Bridge MIB	RFC 1493
MIB for Ethernet-like interfaces (requires support in hardware)	RFC 2665
VLAN MIB	RFC 2674
Spanning Tree Protocol MIB	RFC 1493
Rapid STP MIB	Draft/Prop MIB
Multiple STP MIB	Prop MIB
Link Aggregation MIB	IEEE 802.3ad, additional Prop MIB
Port-based Network Authentication Control MIB	IEEE 802.1X
IPv4 MIB	RFC 2011, 2013, 2096, Prop MIB
IGMP MIB	RFC 2933
DHCP	Prop MIB
RIP v1/v2 MIB	RFC 1723, 1724, 2453, Prop MIB
Radius Client MIB	RFC 2618
OSPFv2 MIB	RFC 1850, Prop MIB
PIM MIB	RFC 2934, Prop MIB
BGPv4 MIB	RFC 1657, Prop MIB
DVMRP MIB	Prop MIB
VRRP MIB	RFC 2787
Tunnel MIB	Prop MIB
IPv6 MIB	RFC 2465, Prop MIB
MLD MIB	RFC 3019, Prop MIB
RIPv6 MIB	Prop MIB
OSPFV3	Draft, Prop MIB

Feature	Standard
Management & Administration	
SNMP v1/v2c/v3 (Both IPv4 and IPv6 based)	RFC 1155, 1157, 1212, 1213, 1215, 1905, 2089, 2578, 3411, 3412, 3413, 3414, 3415, 3416, 3417 (partial), 3584
CLI (Telnet and console) (both IPv4 and IPv6 based)	-
CLI command completion (using Tab)	-
Context Sensitive Help in CLI	-
Multi-session telnet server	-
Web UI (embedded HTTP server) (both IPv4 and IPv6 based)	RFC 1945
Multiple levels of user privileges (CLI And WebUI)	-
TLS Protocol	RFC 2246
SSL Protocol Version 3.0	RFC 2246
SSH Protocol Architecture	Draft
SSH Transport Layer Protocol	Draft
SSH Authentication Protocol	Draft
SSH Connection Protocol	Draft
MIB save/restore using FLASH	-
MIB save/restore through TFTP	-
Trace route logging	-
Log file upload to remote system	-
IP authorized managers	-
Enterprise OID support	-
Chassis Management	-
Power over Ethernet support	IEEE 802.1af
Statistics	
RMON (1, 2, 3 & 9 groups)	IEEE 2819
Port Mirroring	-
Other	
Broadcast Storm Control	-
Stacking Support	-

*Note: Not all RFCs may be listed here. Please contact your local Sales Representative for complete RFC information.



Ruggedization Levels

VPX3-683-Axxxx card: Available in levels 0 and 100 (required airflow is 10cfm at sea level)

VPX3-683-Cxxxx card: Available in levels 200 and 300

Unless otherwise noted environmental tolerance is as defined in the Curtiss-Wright Controls' Ruggedization factsheet.

Part Numbers

Check with your local Curtiss-Wright Controls representative for availability for specific part numbers.

Table 6: Part Numbers

VPX3-683-uvwxxy-zzz	
Part Number	Description
VPX3	3U VITA 46 and 48 form factor
683	Model number
u	Cooling Method A = Air-cooled C = Conduction-cooled
v	Temperature Range 0 = 0 to 50C 1 = -40 to 71C 2 = -40 to 85C
w	Mechanical Format 1 = 0.8" pitch, no 2-level maintenance support 3 = 0.85" pitch, 2-level maintenance support
x	0 = all ports go to back
yy	26 = 24xGbE + 2x10GbE ports
zzz	M3 = Managed BCM 563xx

Table 7: Recommended Variants

Part Number	Description
VPX3-683-A01026-M3	Managed Router, 24 ports 1GbE (SerDes) + 2 ports 10GbE to rear, Layer 2/3 software, Air-cooled, L0, 0.8" pitch
VPX3-683-A11026-M3	Managed Router, 24 ports 1GbE (SerDes) + 2 ports 10GbE to rear, Layer 2/3 software, Air-cooled, L100, 0.8" pitch
PX3-683-C21026-M3	Managed Router, 24 ports 1GbE (SerDes) + 2 ports 10GbE to rear, Layer 2/3 software, Conduction-cooled, L200, 0.8" pitch
RTM3-683-0026	RTM (SFP – all copper, optic or combination) 24 x 1GbE ports, 2 x 10G ports, 2 serial ports, out of band 10/100 debug port, JTAG, Reset)
MNT-683-0000	Yearly Software Maintenance

Warranty

This product has a one year warranty.

Contact Information

To find your appropriate sales representative, please visit:

Website: www.cwembedded.com/sales

Email: sales@cwembedded.com

Technical Support

For technical support, please visit:

Website: www.cwembedded.com/support1

Email: support1@cwembedded.com

The information in this document is subject to change without notice and should not be construed as a commitment by Curtiss-Wright Controls Embedded Computing. While reasonable precautions have been taken, Curtiss-Wright Controls assumes no responsibility for any errors that may appear in this document. All products shown or mentioned are trademarks or registered trademarks of their respective owners.