

General Standards Corporation

High Performance Bus Interface Solutions

18AISS6C

18-Bit, 6-Channel, 550KSPS Analog Input Module With Six Simultaneously Sampled Analog Inputs and 8-Bit Digital I/O Port

Available in PMC, PCI, cPCI and PC104-Plus and PCI Express form factors as:

PMC66-18AISS6C:	PMC, Single-width
PCI66-18AISS6C:	PCI, short length
cPCI66-18AISS6C:	cPCI, 3U
PC104P66-18AISS6C:	PC104-Plus
PCle-18AISS6C:	PCI Express

See Ordering Information for details.

Call for the availability of other form factors, such as XMC, 104-Express, CCPMC, etc.

FEATURES:

- Six differential analog inputs with dedicated 18-Bit ADC per channel
- True simultaneous sampling of all inputs to 550 KSPS per channel
- SAR architecture; No minimum sample rate
- Software-selectable input ranges ¹: $\pm 20V$ (40Vpp), $\pm 10V$, or optional $\pm 10V$, $\pm 5V$ ranges
- Independent 256-Ksample Input FIFO data buffer
- Low noise; >98 dB dynamic range with antialias filter disabled
- Integral antialias filter minimizes out of band components, 200kHz 5th order Chebyshev
- Hardware ADC-Clock and Burst-Trigger I/O for multiboard Operation
- Timing controlled by internal rate generators, by software clocking, or externally
- Internal on-demand autocalibration
- 8-Bit Bidirectional TTL Digital I/O Port
- Two independent 24-Bit frequency dividers
- Completely software-configurable; No field jumpers
- 66 MHz 32-Bit PCI support, with universal 5V/3.3V signaling
- DMA engine minimizes bus congestion
- Single-width PMC form factor with Integral EMI shield
- Internal power conversion; Dual regulation for maximum supply integrity
- Available on adapters for alternate form factors, including PCI, cPCI and PC104-Plus, as well as PCI-Express, PCIX and cPCIX

¹ Input range is defined here as the entire active range of voltage differences between the two conductors in a differential HI/LO input pair. ¹Equal to $\pm V_{pk}$, or $\pm 1/2 * V_{pp}$.

TYPICAL APPLICATIONS:

- ✓ High-resolution data acquisition
- ✓ Precision voltage measurement
- ✓ Transient analysis
- ✓ Event capture
- ✓ Position monitoring
- ✓ Research instrumentation

- PRELIMINARY -

REV: 040110

FUNCTIONAL DESCRIPTION

The 18AISS6C is a precision 18-Bit analog input product that provides six simultaneously sampled low-noise input channels. The inputs can be sampled at rates from zero to 550 KSPS per channel, and are supported by a 256K-Sample FIFO data buffer. Both continuous and burst clocking modes are supported, and voltage ranges are software-selectable as $\pm 20V$ and $\pm 10V$ differential (line-to-line), or optionally as $\pm 10V$ and $\pm 5V$. Sampling and triggering rates can be derived from internal rate generators, or from external clock and trigger sources to support the synchronous operation of multiple boards.

Input sampling employs successive-approximation (SAR) conversion, which eliminates the high latency or minimum-rate limitations of delta-sigma and pipelined conversion schemes. Single-ended inputs can be accommodated by grounding the low side of each differential input pair. A fifth-order analog lowpass filter can be inserted into the signal path under software control, and can be employed to minimize the presence of aliased out-of-band signal components.

On-demand autocalibration determines and applies error correction for all input channels, and a selftest input switching network permits board integrity to be verified by the host. Eight bidirectional digital I/O lines are programmable as inputs or outputs.

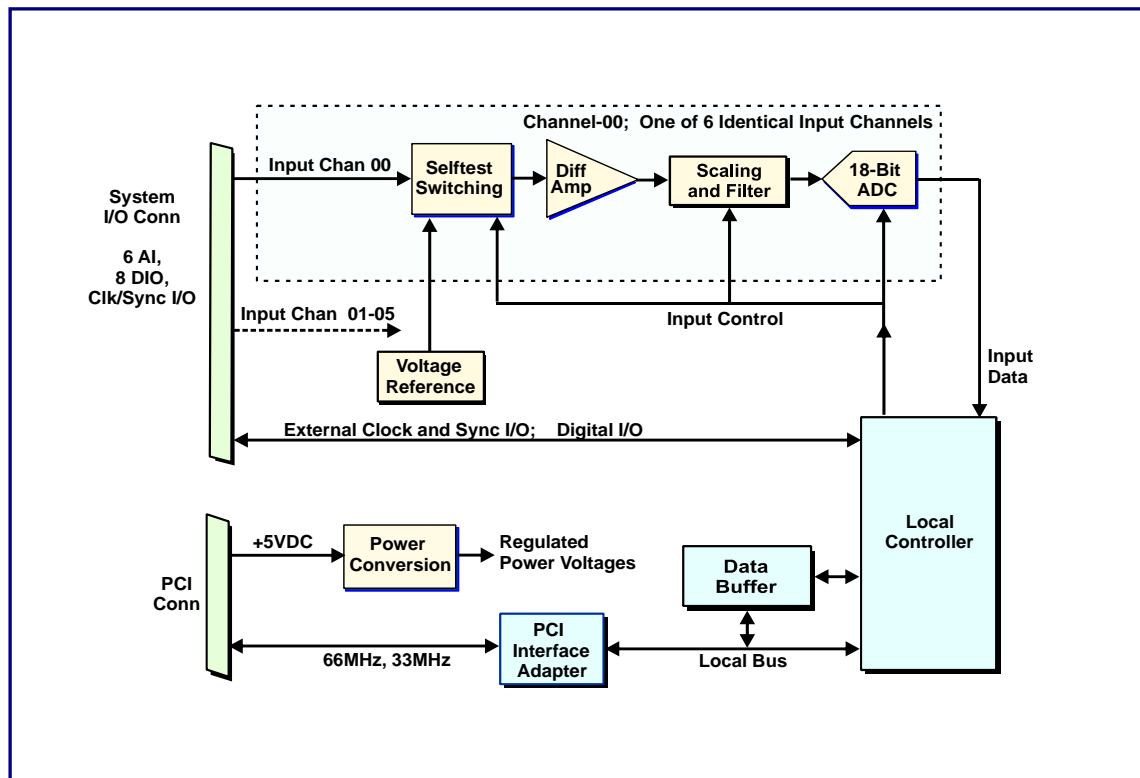

Figure 1. 18AISS6C; Functional Organization

This product complies with the IEEE PCI local bus specification Revision 2.3. System connections are made at the front panel through a high-density dual-ribbon 68-pin connector. Power requirements consist of +5 VDC in compliance with the PCI specification, and analog power voltages are generated internally. Operation over the specified temperature range is achieved with conventional air cooling.

PERFORMANCE SPECIFICATIONS

At +25 °C, with specified operating voltages

Analog Input Characteristics:

Configuration:	Six simultaneously sampled input channels with dedicated 18-Bit SAR ADC per channel. Optional 4-Channel and 2-Channel configurations available.
Voltage Ranges:	±20V or ±10V full scale for all input channels, software-selectable. Optionally selectable as ±10V or ±5V; See ordering information.
Input Impedance:	2 Megohms ±20%; typical; line-line in parallel with 80pF.
Bias Current:	2-Chan Config: 50 nanoamps typical, all ranges. 4,6-Chan Config: 100 nanoamps typical, all ranges.
Crosstalk Rejection:	90dB typical DC-50kHz. 80dB at 250kHz.
Common Mode Rejection:	65dB DC-80kHz; 50dB at 500kHz. Typical with CMV = ±11V, Vin = Zero.
Input Voltage Limits	±11V line-ground on any input for normal operation.
Overvoltage Protection:	±35V line-ground or line-to-line with power applied or removed.

Input Transfer Characteristics:

Resolution:	18 Bits (0.0004 percent of FSR)		
Sample Rate:	Zero to 550KSPS per channel.		
Sampling Mode::	Simultaneous; Successive-approximation conversion, all inputs active.		
DC Accuracy: (Maximum composite error after autocalibration)	<u>Range *</u>	<u>Midscale Accuracy</u>	<u>±Fullscale Accuracy</u>
	±20V	±0.8mV	±3.0mV
	±10V	±0.5mV	±1.9mV
	±5V	±0.3mV	±1.2mV
	* Input range is defined here as the entire active range of voltage differences between the two conductors in a differential HI/LO input pair. 'Equal to ±Vpk, or ±1/2*Vpp.		
Small Signal Bandwidth:	Zero to 800kHz, -3dB with the filter disabled, or Zero to filter frequency if enabled.		
Input Filter:	Selectable either as 'no filter', or as a 5th order Chebyshev, 200kHz, 0.5dB, continuous-time lowpass analog filter.		
Settling Time:	2us to 0.1% for halfscale step; typical with input filter disabled.		
Input Power Bandwidth:	2-Chan Config: 4.8 Vpp-MHz; -3dB; typical. 4,6-Chan Config: 11 Vpp-MHz; -3dB; typical.		
Dynamic Range, Typical, ±20V Range, 500KSPS	<u>Freq Range</u>	<u>Filter Disabled *</u>	<u>Filter Enabled *</u>
	10Hz - 10kHz	99dB / 99dB	99dB / 99dB
	10Hz - 30kHz	99dB / 97dB	97dB / 93dB
	10Hz - 100kHz	95dB / 93dB	84dB / 81dB
	10Hz - 200kHz	92dB / 88dB	72dB / 70dB
	* The first figure refers to a 2-Channel board; the second figure applies to 4 and 6-Channel boards		
Integral Nonlinearity:	±0.002 percent FSR. (FSR = fullscale range; e.g.: 40V on ±20V range).		
Differential Nonlinearity:	±0.001 percent FSR		

Input Operating Modes and Controls

Input Data Buffer:	256K-sample FIFO
Input Data Format:	18 Bits, selectable as offset binary or two's complement coding, with attached channel number and end-of-burst tag.
Sample Clock Sources:	Internal rate generator; External Hardware Clock I/O, Software clock.
Sampling Modes:	Continuous sampling or triggered burst.
Internal Rate Generators:	Two independent rate generators, one for ADC clocking; one for burst triggering. Both programmable from 3-550,000 sample clocks per second, using 24-Bit dividers from the master clock frequency.
External Sync I/O:	TTL, clock and burst trigger. Zero to 550,000 sample clocks per second.
Auxiliary External Clk/Sync:	Internal connector supports external clock and sync (trigger) control within the enclosure.

Digital Input/Outputs:

Eight TTL I/O lines in two groups of four bits, group-configurable as inputs or outputs. 0.2ma maximum input loading as current source, 8ma output loading as either source or sink. Direct register control.

PCI Compatibility:

Conforms to PCI Specification 2.3, D32 read/write, 33/66MHz, universal (5V/3.3V) signaling, Supports block-mode and demand-mode DMA data transfers as bus master in either of two channels.

PHYSICAL PARAMETERS

Power Requirements:

+5VDC \pm 0.2 VDC at 1.3 Amps typical for 2-Channel and 4-Channel configurations; 1.6 Amps typical for 6-Channel configuration.

Maximum Power Dissipation: Side-1: 6.8 Watts. Side-2: 2.5 Watts.

Mechanical Characteristics (PMC form factor)

Height: 13.5 mm (0.53 in)
Depth: 143.75 mm (5.66 in)
Width: 74.0 mm (2.91 in)

Environmental Specifications

Ambient Temperature Range:

Standard Temperature: Operating: 0 to +70 Degrees Celsius *
Storage: -40 to +85 Degrees Celsius

Extended Temperature: Operating: -40 to +80 Degrees Celsius *
Storage: -40 to +85 Degrees Celsius

* Air temperature at board surface.

Relative Humidity: 0 to 95%, non-condensing

Altitude: Operation to 10,000 ft.

Cooling: Conventional air cooling; 150 LFPM

ORDERING INFORMATION

Specify the basic product model number followed by an option suffix "-A-B-C-D-E", as indicated below. For example, model number **PMC66-18AISS6C-2-20V-F1-45M** describes a PMC module with two input channels, high-level input ranges ($\pm 20V, \pm 10V$), standard F1 filter type, standard 45MHz master clock frequency, and no custom features.

Basic Model Number	Form Factor
PMC66-18AISS6C	PMC (Native)
PCI66-18AISS6C ^{1,2}	PCI, short length
cPCI66-18AISS6C ^{1,2}	cPCI, 3U
PC104P66-18AISS6C ^{1,3}	PC104-Plus
PCle-18AISS6C ^{1,3}	PCI Express

¹ Contact factory for availability in native form factors.

² PMC module installed and tested on an adapter, with mechanical and functional equivalency.

³ PMC module installed and tested on an adapter, with functional equivalency.

Optional Parameter	Value	Specify Option As:
Number of Input Channels	2 Channels	A = 2
	4 Channels	A = 4
	6 Channels	A = 6
Input Range Set	Software-selectable $\pm 20V$ or $\pm 10V$	B = 20V
	Software-selectable $\pm 10V$ or $\pm 5V$	B = 10V
Lowpass Input Filter Type	Chebyshev, 200kHz, 5th order, 0.5dB	C = F1
	Custom filter characteristics.	C = F2, F3, etc.
Master Clock Frequency: (Standard frequency is 36 MHz)	Standard frequency = 45.000 MHz	D = 45M
	Specify nonstandard frequency ¹	D = (frequency, MHz)M
Custom Features ²	---	E = Blank unless custom feature is specified

¹ 45-48MHz. Contact factory for availability of nonstandard frequencies.

² Contact factory for availability of custom features.

SYSTEM INTERFACE CONNECTOR

Table 1. System I/O Connector

ROW-A		ROW-B	
PIN	SIGNAL	PIN	SIGNAL
1	INPUT RTN	1	DIGITAL RTN
2	INPUT RTN	2	DIGITAL RTN
3	INPUT 00 LO	3	DIGITAL RTN
4	INPUT 00 HI	4	DIGITAL RTN
5	INPUT RTN	5	DIGITAL RTN
6	INPUT RTN	6	DIGITAL RTN
7	INPUT 01 LO	7	DIGITAL RTN
8	INPUT 01 HI	8	DIGITAL RTN
9	INPUT RTN	9	DIGITAL RTN
10	INPUT RTN	10	DIGIO 00
11	INPUT 02 LO	11	DIGITAL RTN
12	INPUT 02 HI	12	DIGIO 01
13	INPUT RTN	13	DIGITAL RTN
14	INPUT RTN	14	DIGIO 02
15	INPUT 03 LO	15	DIGITAL RTN
16	INPUT 03 HI	16	DIGIO 03
17	INPUT RTN	17	DIGITAL RTN
18	INPUT RTN	18	DIGIO 04
19	INPUT 04 LO	19	DIGITAL RTN
20	INPUT 04 HI	20	DIGIO 05
21	INPUT RTN	21	DIGITAL RTN
22	INPUT RTN	22	DIGIO 06
23	INPUT 05 LO	23	DIGITAL RTN
24	INPUT 05 HI	24	DIGIO 07
25	INPUT RTN	25	DIGITAL RTN
26	INPUT RTN	26	INP TRIG OUT *
27	VTEST LO	27	DIGITAL RTN
28	VTEST HI	28	INP TRIG INP *
29	INPUT RTN	29	DIGITAL RTN
30	INPUT RTN	30	INP CLK OUT *
31	INPUT RTN	31	DIGITAL RTN
32	INPUT RTN	32	INP CLK INP *
33	INPUT RTN	33	DIGITAL RTN
34	INPUT RTN	34	DIGITAL RTN

* TTL, asserted LOW.

Table 2. Sync-I/O Connector (Side-2)

PIN	SIGNAL
1	DIGITAL RTN
2	AUX CLOCK I/O
3	DIGITAL RTN
4	AUX SYNC I/O
5	DIGITAL RTN
6	(No internal connection)

Recommended Sync-I/O mating cable connector is:
Molex# 51146-0600.

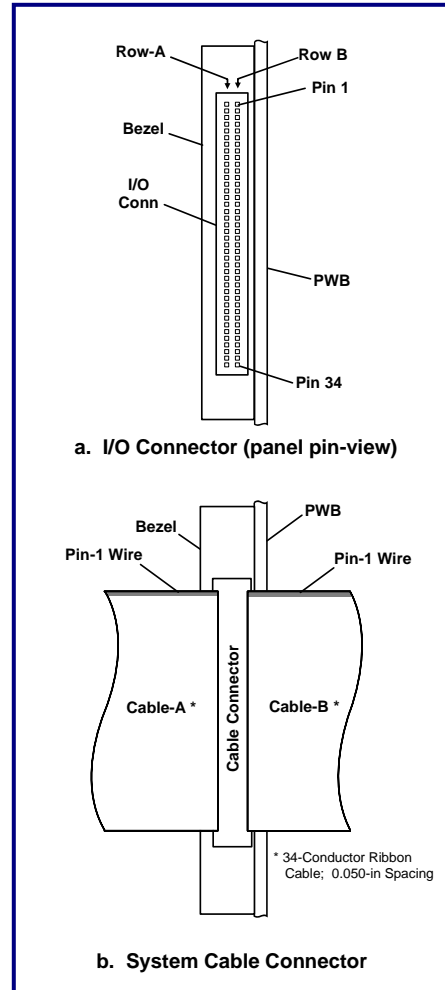

Figure 2. System I/O Connector

System Cable Mating Connector:

68-pin 0.050" Subminiature connector with metal shield:
AMP #749621-7 or equivalent.

I/O Connector Installed on Board (Ref):

Amp # 787170-7.

General Standards Corporation assumes no responsibility for the use of any circuits in this product. No circuit patent licenses are implied. Information included herein supersedes previously published specifications on this product and is subject to change without notice.