

# XMC Carrier / Adapter

## XMC to PCI Express Adapter

This carrier is designed to adapt an XMC to an 8-lane PCI Express slot.

JN4 is provided for access to rear I/O, PN1 and PN2 are build options but only provide +3V, +5V, +12V and -12V to the XMC card and do not provide PCI signal connections.

Several activity LEDs located at the edge of the board give an indication of key XMC and PCI express signals and voltages.

The signals unique to the XMC standard such as GA[2..0], MVMRO and ROOT0 are supported by DIP switch settings.

The JTAG signals from the PCI bus and the PCI express bus are brought out to headers allowing users the option of connecting the two JTAG ports. The I2C connections for both buses are available on the same connector as well. These jumpers are populated by default.

A high quality 2.5 mm thick machined aluminum panel, with a 0.5 mm chamfered edge, is provided on the PCI board bracket. This mimics the mechanics of a XMC installed on a VMEbus board or

other host environments and allows the XMC bezel to be firmly positioned on the board.

For access to the XMC P16 connector for user I/O, consider Technobox P/N 4821 which connects all P16 signals to 0.1 inch headers.

The A and C rows of a 96-pin DIN connector connect with the 64-pin user I/O connector (J4/P4) on the mezzanine card. This connection is specified by IEEE 1386 for the P2 connector on VMEbus boards and permits internal connection of rear I/O, should the PMC board support rear I/O connectivity.

Two variants (P/Ns 5934 and 5935) support 4X and 1X slots. Additional variants (P/Ns 6065, 6066, and 6067) - based on 5V VPWR - are available and support 8X, 4X, and 1X respectively.

An optional fan assembly (P/N 4936) is available that fits over two XMC-to-PCI express adapter boards and provides substantial forced-air cooling of high-power modules.



**5933**  
.....

- Adapts an XMC to a PCIe Slot
- Supports 1X, 4X, 8X, and 16X PCIe Lanes
- Supports +5V or +12V for XMC VPWR
- JN4/PN4 General Purpose I/O
- 2.5 Gb/s per Lane (each direction)
- LEDs for Key PCI and PCIe Signals and Voltages
- Headers Provide Access to JTAG and I2C signals
- Optional fan assembly to augment cooling
- Industrial temperature
- RoHS-compliant, Lead-free

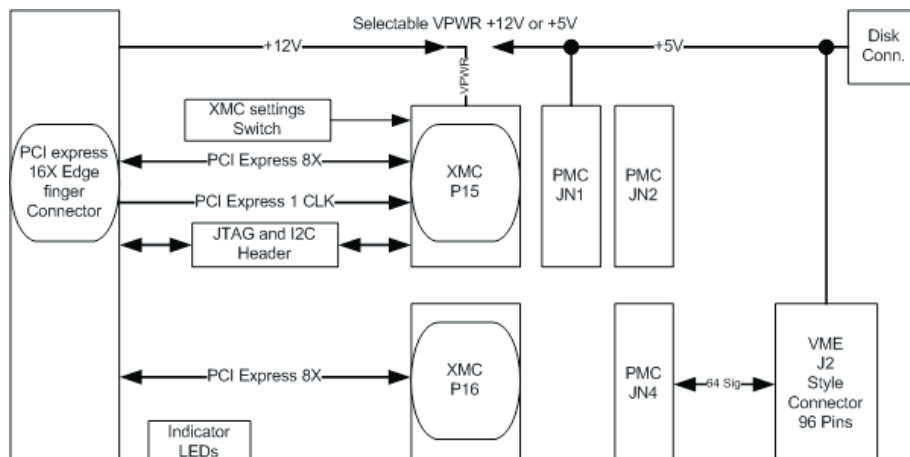

**Technobox**

