



PRODUCT DATASHEET

UNITRONIX Pty Ltd

PO Box 486, Morisset NSW 2264

NSW: Tel: 61 2 4977 3511 Fax: 61 2 4977 3522

WA: Tel: 61 8 9455 2424 Fax: 61 8 9455 2458

unitsyd@unitronix.com.au www.unitronix.com.au

PMC-706

Dual Independent Graphics Output PMC

Features

- ATI Technologies RADEON™ Mobility 9000 Visual Processor Unit with
 - 64 Mbytes integrated high-speed DDR SDRAM
 - Integrated NTSC/PAL, TMDS, LVDS video output
 - Hardware OpenGL acceleration
- Dual independent Analog and Digital video outputs
 - Non-Interlaced analog
 - NTSC, PAL, RS-170 and S-Video (single output only)
 - DVI (Digital Visual Interface, also known as PanelLink) TMDS (Transition Minimized Differential Signaling)
 - LVDS supporting OpenLDI and FlatLink
- Analog outputs support separate horizontal and vertical, composite or sync on red/green/blue
- Video Capture and Format (VCF) module for custom LVDS video mode support
- Complete software support featuring our Graphics Software Suite
 - Optimized full X11 Server with Extensions
 - Optimized OpenGL 1.3 driver
 - Extensive output mode support and configuration
 - Host support for MS Windows NT/2000 and Solaris (Sparc)
- Comprehensive Operating System support
 - VxWorks Tornado
 - GreenHills INTEGRITY
 - Linux
- PCI rev 2.1 compliant, 32-bit 33/66Mhz capable
- Voltage requirements: +5v and +/- 12v
- Available in all ruggedization levels

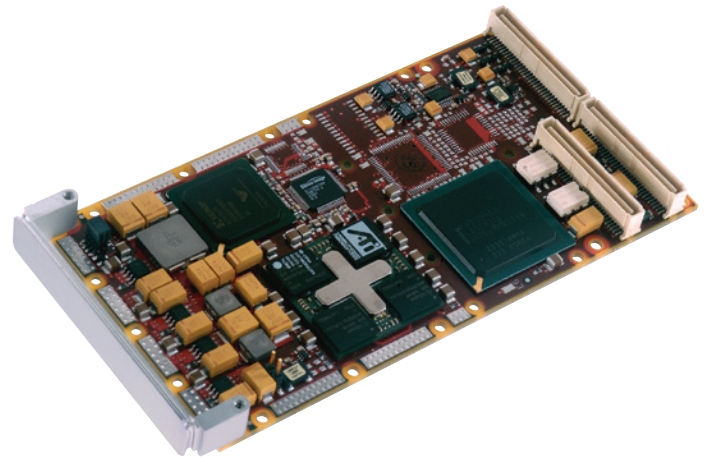

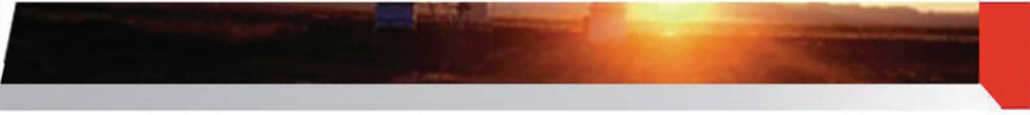
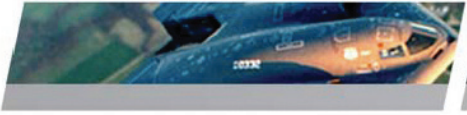

Overview

The PMC-706 is a PCI Mezzanine Card (PMC) form factor, ruggedized, high-performance, feature rich Graphics PMC. This IEEE 1386.1 PMC will provide a platform for customers to design, develop and deploy high-performance graphics sub-systems capable of supporting high-performance, dual headed synthetic graphics outputs. With support for both legacy and new video interfaces, the PMC-706 is an ideal solution for both new and retrofit ground, naval and avionics platforms.

The PMC-706 is the first rugged COTS PMC to make use of the industry leading ATI Radeon Mobility 9000 (M9) Visual Processing Unit (VPU). By incorporating the ATI M9 graphics controller, Curtiss-Wright leverages ATI's 18 years of experience in developing and producing graphics controllers for the embedded, mobile and desktop markets. The M9 features integrated memory, integrated video input and output, advanced de-interlacing hardware and industry leading, high-performance 2D/3D/Video acceleration.

The PMC-706 combines the M9's feature/integration mix with our proven ability to produce high-performance rugged graphics products interfacing to today's emerging and established standards in Defense and Aerospace display/sensor systems.

The PMC-706 is targeted at applications requiring high-speed presentation of synthetic graphics with up to two independent analog/digital displays. Software support is provided through our Graphics Software Suite which includes a fully embeddable X11 server and OpenGL graphics interface. This is offered for multiple RTOS environments and is optimized to provide maximum performance and reliability.

Through the onboard Video Capture and Format (VCF) module, PMC-706 can accommodate Barco LVDS mode as well as custom LVDS output formats often found in retrofit environments.

From head down displays to target-and-acquisition displays to moving map displays to helmet mounted displays, our graphics PMCs, Imaging Platforms and Graphics Software Suite are the ideal graphics foundation for today's D&A demanding graphics and imaging platforms.

ATI RADEON Mobility 9000 (M9)

PMC-706 is powered by the industry-leading ATI Radeon Mobility 9000 (M9) Visual Processing Unit (VPU). ATI is the market leader in mobile graphics providing graphics processors to the premier mobile computing suppliers such as Dell, IBM, Sony and Toshiba. The M9's integrated feature set, performance and flexibility are unparalleled in the embedded graphics market. Some of the M9 features include:

- Graphics Clock: 250 MHz
- Integrated Memory: 64MB DDR SDRAM, 128 Bits wide, 200 Mhz clock speed
- Video Output capabilities
 - Integrated LVDS
 - Integrated TV output (NTSC, PAL)
 - Integrated TMDS
 - High 2D/3D resolution (up to 2048x1536)
 - Color depth of 16.7M colors
- Integrated Digital Video Input port (VIP2)

The M9 delivers high performance coupled with low power consumption in the most integrated VPU package on the market today.

Figure 1: PMC-706 Architecture Diagram

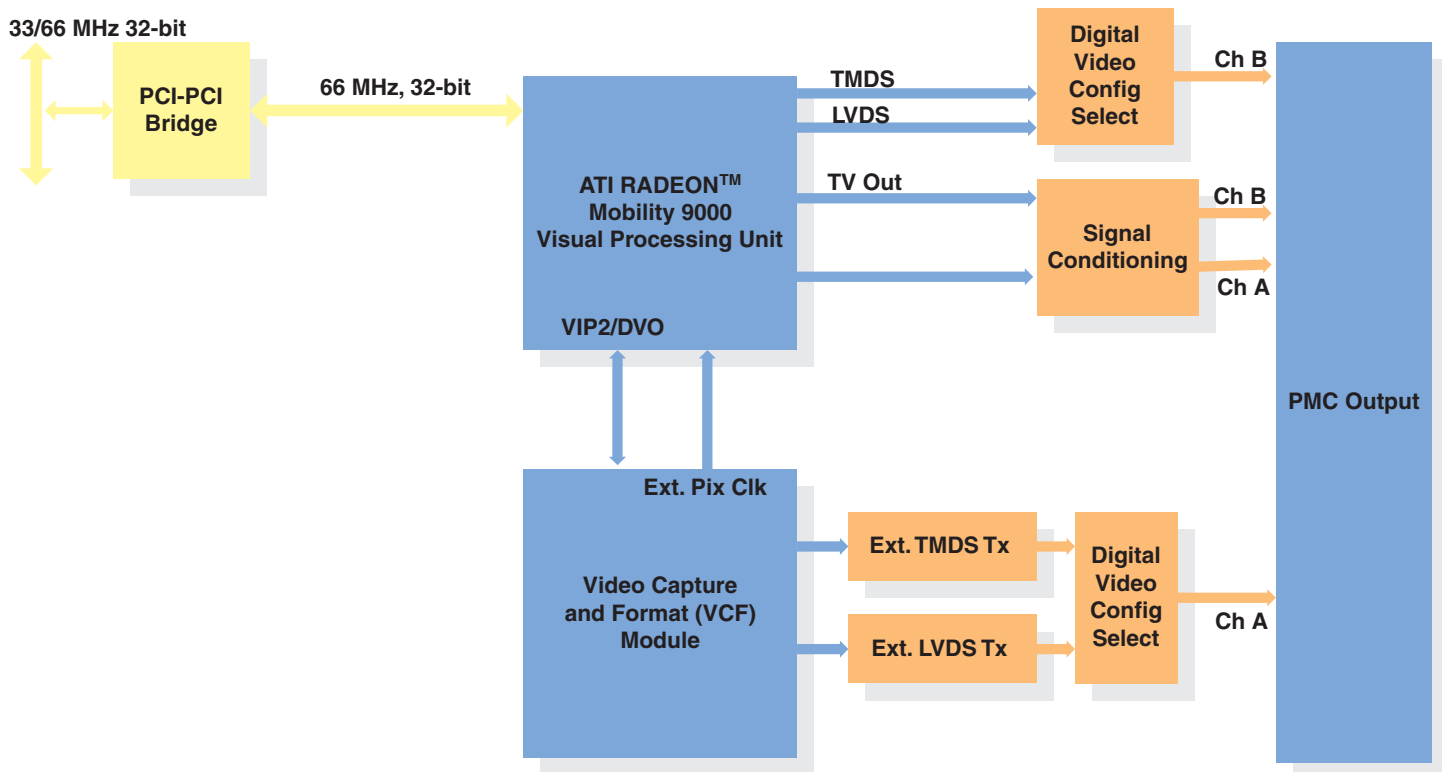

Video Output

The PMC-706 provides a variety of video output capabilities. Both analog (non-interlaced or interlaced) and digital (DVI or LVDS) can be presented simultaneously in real-time.

The PMC-706 offers true dual channel video output support capable of driving two (2) independent analog and digital channels from the same PMC. Most of the video output modes are selected through runtime software (see Figure 2).

Analog Non-Interlaced Video Output

The PMC-706 provides two independent non-interlaced RGB analog outputs with separate or composite horizontal and vertical syncs. These outputs support non-interlaced video standards from 640 x 480 to 1600 x 1200 at various refresh rates. Our Graphics Software Suite allows the user to easily select the desired resolution and refresh rate from an extensive list of supported modes as illustrated in Table 1. PMC-706 can also be configured to provide a composite sync on the green, red or blue signal of channel A or B. (sync on green is the default configuration, sync on red/blue is available through a build option)

Figure 2: PMC-706 Video Output Configuration Options

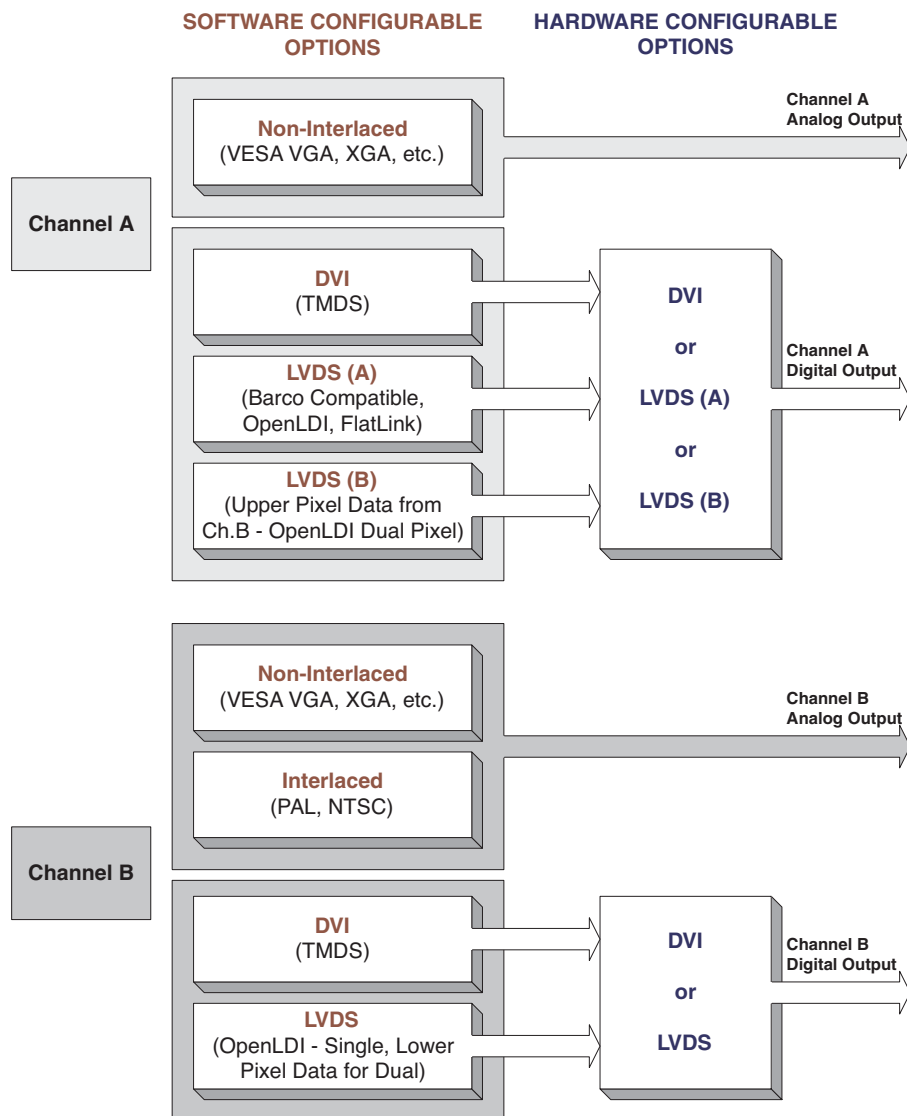

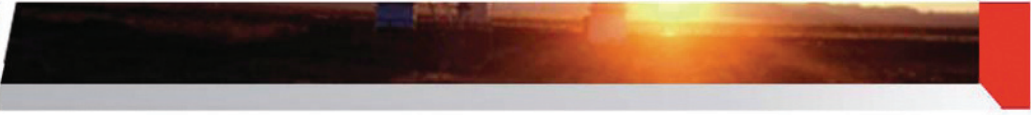

Analog Interlaced Video Output

The PMC-706 provides one interlaced analog video output supporting the following output formats, in either composite or S-Video:

- NTSC
- PAL
- RS-170 (composite only)

Digital DVI Output

The PMC-706 provides two high-speed industry standard Digital Visual Interface (DVI) video outputs that are compatible with many commercially available digital monitors.

DVI is also known by the trade name Panel-Link® and employs Transition Minimized Differential Signaling (TMDS) technology. The PMC-706 DVI outputs utilize a four differential pair interface supporting display resolutions up to 1280 x 1024 at a 60 Hz refresh rate. Note that DDC is not supported on either DVI output. Using DVI, displays or other receiving electronics such as video mixers can be readily constructed using off-the-shelf support devices, saving the time and expense of designing proprietary solutions.

One of the TMDS interfaces is implemented through the our VCF module while the other is implemented directly in the M9.

Digital LVDS Output

PMC-706 provides two outputs, each offering five (5) pairs of Low-Voltage Differential (LVDS) signaling, to enable the transmission of video data in digital form.

The LDVS interface supports various video protocols including FlatLink and OpenLDI. One of the LVDS interfaces is directly implemented through our VCF module while the other is implemented in the M9. Our VCF supports interfaces such as those found on BARCO displays and allows different LVDS digital video protocols to be accommodated. Contact us directly should you require this service.

The two (2) independent digital outputs may be configured be configured to support single-pixel LVDS with resolutions up to 1024 x 768 @ 60Hz.

Table 1: PMC-706 Video Output Modes**

Video Mode	Resolution	Refresh Freq. (Hz)	Color Depth (bits)*	Output Channel	Notes
Analog Non-Interlaced	640 x 480	60, 75, 85, 100	16, 32	A, B	-
	800 x 600	60, 75, 85, 100	16, 32	A, B	-
	1024 x 768	60, 75, 85, 100	16, 32	A, B	-
	1152 x 864	60, 75, 85, 100	16, 32	A, B	-
	1280 x 1024	60, 75, 85, 100	16, 32	A, B	-
	1600 x 1200	60, 75	16, 32	A, B	-
Analog Interlaced	RS-170 640 x 480	30	16, 32	A	-
	PAL	25	16, 32	B	-
	NTSC	30	16, 32	B	-
	S-Video (Y/C)	30	16, 32	B	-
Digital DVI (TMDS)	up to 1280 x 1024	60	16, 32	A, B	-
	1600 x 1200	-	-	B	-
Digital LVDS (OpenLDI/FlatLink)	up to 1024 x 768	60	16, 32	A, B	1
	Barco LVDS	-	-	A	-

Notes:

1. Max pixel clock rate of 65Mhz on Channel A

* All Video is output at 24bits of RGB color depth ** Call to confirm refresh rates

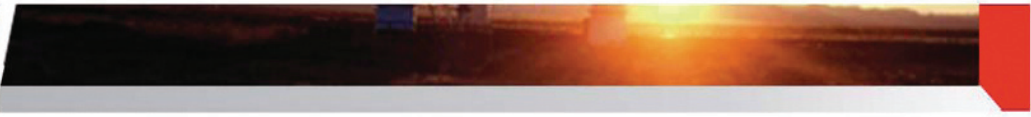

Synchronization

Sync On Green

Just as with the PMC-702, PMC-706 supports the insertion of a composite sync signal on both of the non-interlaced and interlaced analog video outputs. This sync signal can be inserted on either the green channel, or in the case of certain video standards, the Red, Green and Blue channels. The sync on green feature is commonly required for interlaced displays, removing the need for separate horizontal and vertical syncs.

Video Capture and Format module (VCF)

Our 12+ years in D&A graphics and imaging products has led to the development of the Video Capture and Format module technology. The VCF on the PMC-706 is derived from the PMC-704's VCF and provides the ability to accommodate custom LVDS output requirements as well as support for Barco LVDS. Custom video mode support through the VCF is provided as a value-added service. Contact your local representative for more information.

Power Management

Even though PMC-706 provides an excellent performance-to-watt ratio, a number of power management features are supported in order to minimize system power requirements. Through our Graphics Software Suite, user-configurable power management can be obtained through control of the M9's 2D and 3D cores and through the GPU core and memory clock control.

Built-In-Test (BIT)

BIT for PMC-706 is provided by firmware routines within our Card Level Diagnostics (CLD) package. CLD is part of the Foundation Firmware suite of firmware components delivered in the Flash memory of our SBCs.

Video I/O Breakout Module

The PMC-706 routes all its I/O through the Pn4 connector, which in turn is routed to the P0 or P2 connector of the host board. For development, it can be more convenient to have the I/O signals available at the front panel of the system. To accommodate customers who would prefer to have front panel access to the PMC-706 I/O signals, a FrontPack module is available separately. The FrontPack is a PMC form-factor module that is interposed between the basecard and the PMC-706. The FrontPack redirects the I/O signals to industry-standard RCA, DVI and 15-pin D-type (VGA) connectors located at the front panel. With the FrontPack installed, the assembly will intrude into the adjacent slot. The FrontPack is intended for development use and is not qualified for rugged applications.

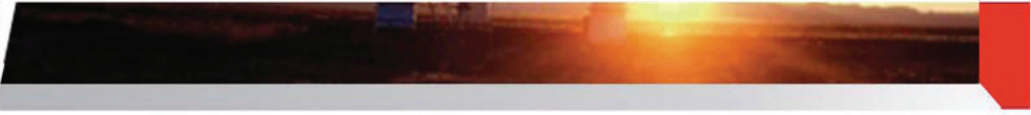

Graphics Software Support

Graphics software support is offered through our Graphics Software Suite (GSS). We designed and provide support for the GSS to ensure the highest level of integration with the graphics and hardware. Windows and Solaris hosted development environments are supported as are a number of target system RTOS' such as INTEGRITY, VxWorks and others. See the Graphics Software Suite datasheet for complete details.

The Graphics Software Suite for PMC-704 and PMC-706 offers:

OpenGL Graphics Interface



- OpenGL v1.3 driver and libraries
- Multi-window capabilities (i.e. multiple OpenGL windows under VxWorks)
- Snapshot video capture and output support (PMC-704 only)
- Configuration libraries and utilities to allow the setting of the configuration parameters
- Comprehensive documentation set
- Supported under Green Hills INTEGRITY and Wind River VxWorks



X11 Server

- Full X11R6.4 server, libraries, etc.
- Multi-window capabilities (i.e. multiple X windows)
- Configuration utilities to allow the setting of the configuration parameters
- Video capture capabilities through Xv (PMC-704 only)
- GLX extension to allow integration with the OpenGL Graphics Interface
- Other X11 extensions
- Comprehensive documentation set
- Supported under Green Hills INTEGRITY and Wind River VxWorks



WIND RIVER

Table 2: Specifications

RUGGEDIZATION LEVELS*		
SPMC card	Available in levels 0 and 100	
DPMC card	Available in levels 100 and 200	
ESTIMATED POWER REQUIREMENTS		
+5 V	1.3 A (typical)	1.9 A (maximum)
+12V	70mA (typical)	80mA (maximum)
-12V	55mA (typical)	60mA (maximum)
DIMENSIONS	Size	Weight
SPMC card	Per IEEE 1386.1	131 g
DPMC card	Per IEEE 1386.1 (ANSI/VITA 20-2001)	117 g
*Refer to Ruggedization Guidelines for more details.		



Contact Information

To find your appropriate sales representative, please visit:

Website: www.cwembedded.com/sales

Email: sales@cwembedded.com

For technical support, please visit:

Website: www.cwembedded.com/support1

Email: support1@cwembedded.com

The information in this document is subject to change without notice and should not be construed as a commitment by Curtiss-Wright Controls Inc., Embedded Computing (CWCEC) group. While reasonable precautions have been taken, CWCEC assumes no responsibility for any errors that may appear in this document. All products shown or mentioned are trademarks or registered trademarks of their respective owners.