



Data Sheet

PMC-E2202

Quad Channel 160MSPS

Digital Receiver PMC

UNITRONIX Pty Ltd

PO Box 486, Morisset NSW 2264
 NSW: Tel: 61 2 4977 3511 Fax: 61 2 4977 3522
 WA: Tel: 61 8 9455 2424 Fax: 61 8 9455 2458
 unitsyd@unitronix.com.au www.unitronix.com.au

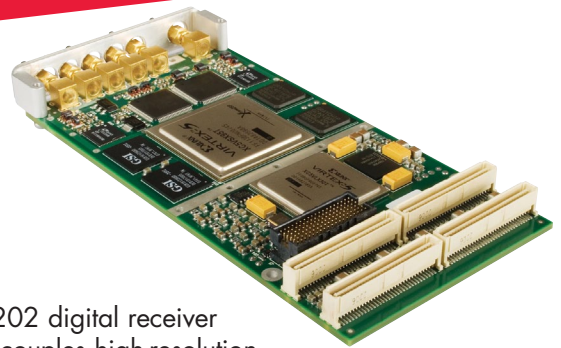

Applications

- ◆ Software Radio
- ◆ Signal Intelligence
- ◆ Spectral Analysis
- ◆ Radar

Features

- ◆ Four channels of 160MSPS, 16-bit analog to digital conversion
- ◆ Xilinx® Virtex®-5 SX95T FPGA (user programmable)
- ◆ Firmware Development Kit (FDK)
- ◆ Two banks of 512Kx36b ZBT RAM memory
- ◆ Capable of multi-board synchronization
- ◆ Front panel and/or user I/O triggering
- ◆ Comprehensive Built-in Test (BIT)
- ◆ XMC/PMC form factor
- ◆ Rugged versions
- ◆ Wind River® VxWorks® and Wind River® GPP Linux® driver support

Benefits

- ◆ Combined acquisition and data processing
- ◆ Industry standard form factor

Overview

The PMC-E2202 digital receiver PMC closely couples high-resolution analog-to-digital converters (ADCs) with a large capacity Xilinx® Virtex®-5 FPGA, resulting in an extremely flexible digital receiver solution for software radio, signal intelligence and radar applications that need high dynamic ranges and sophisticated signal processing.

The PMC-E2202 uses four ADCs with 16-bit resolution to provide outstanding performance in signal-to-noise ratio (SNR) and spurious-free dynamic range (SFDR). Analog to digital conversion rates of up to 160MSPS allow for direct sampling of the most popular IF frequencies for radar systems and the capture of instantaneous bandwidths greater than 60MHz, an important feature for communication applications. In addition, the high input bandwidth on each channel allows frequencies up to 350MHz to be digitized without the need for external down-conversion circuits.

Analog Input

Four analog inputs are supported through front panel SMC connectors. Each input is AC coupled via transformers and has an impedance of 50Ω. Analog input bandwidth exceeds 350MHz, allowing under-sampling of the input signals. No anti-aliasing filters are fitted. Our technical support engineers can offer advice regarding suitable external filtering to limit the input signal bandwidth to user requirements.

Learn More

Web / sales.cwembedded.com

Email / sales@cwembedded.com

ABOVE & BEYOND

**CURTISS
WRIGHT** Controls
Embedded Computing

cwembedded.com



Clock Input

The PMC-E2202 can be ordered with an internal or external clock through a factory build option. A PMC-E2202 with an external front panel clock input is able to accept clock input frequencies ranging from 1 to 160MHz.

A/D Converters

The PMC-E2202 provides four Linear Technologies LTC2209 16-bit analog to digital converters sampling at clock rates of up to 160MSPS. The board has been designed to support independent operation of the acquisition channels from collection right through to the host PCI-X interface.

The ADCs run continuously, removing the settling time problems and noise associated with switching ADCs on and off. Gating of the sample data is controlled by the trigger input.

Trigger Signal

The front panel SMC connector will accept TTL level trigger signals. Alternatively, an external trigger may be provided across the PMC user I/O connector, P14. In this case, the user programmable FPGA will need to be configured to accept this input.

Built-in Test

The analog subsystem includes four AD9744 14-bit, 160MHz digital to analog converters (DACs). These DACs allow full testing of the input subsystem by allowing a digital test pattern to be converted to analog and looped back into the ADC input. Input integrity can be verified by using data containing a number of known tones spread over the full dynamic range and selectively filtering these tones.

FPGA

A Xilinx Virtex-5 SX95T FPGA provides the user-definable signal processing resource. Two banks of 512Kx32b ZBT RAM are directly interfaced with the FPGA to support signal processing operations with high-speed interim storage. More than 90% of the Virtex-5 resource is available for user/application-specific digital receiver and DSP algorithms.

The primary data path is through the command and control FPGA and onto a PCI-X (64-bit, 133MHz) interface to the host.

Development Support

The PMC-E2202 has device driver support for Wind River® VxWorks® and Wind River® GPP Linux®. The driver support includes a broad function application programming interface (API) in C. The package also includes examples and utilities to capture data, run BIT and display information about the board.

An FDK is available that provides HDL source code for the hardware interfacing modules, such as the ADCs, SRAM and local bus to the command and control Xilinx FPGA. The kit allows the user to develop proprietary algorithms using third-party tools and/or incorporate off-the shelf IP for DDCs and DSP algorithms, in the form of IP cores.

Example IP Core: Wideband DDC

Curtiss-Wright Controls can deliver a Wideband Digital Down Converter (DDC) providing similar functionality to the TI GC1012B in a Xilinx® Virtex®-5 SX95T. It is available pre-configured for the PMC-E2202.

The core permits scaling of the input signal by up to 72dB with a granularity of 0.03dB. The NCO has a 32-bit accumulator and 21-bit output to the mixer delivering 120dB SFDR. The FIR filter decimates and filters the complex output of the mixer, supporting decimation rates of 2, 4, 8, 16, 32 and 64.

The pre-programmed filter sets can be reprogrammed at runtime, filter sets other than the set in use can be updated at runtime without disturbing the operation of the filter.

For complete specifications of this IP core, please consult the DDC001 datasheet.

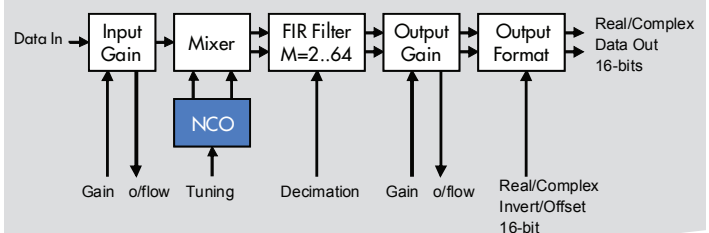



Figure 2: PMC-E2202 Block Diagram

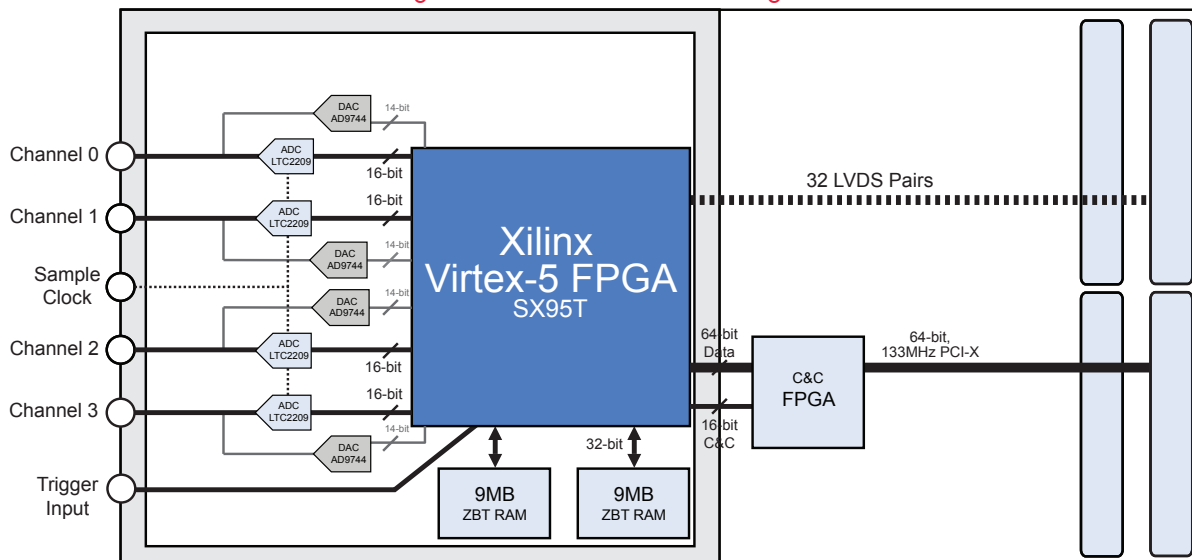

Table 1: Specifications

FPGA	
Device	Xilinx Virtex-5 SX95T (speed grade 2)
C&C FPGA	Xilinx Virtex-5 LX30T
ZBT RAM	2 banks of 512Kx32b
Analog Input	
ADC Device	Linear Technology LTC2209
Number of Channels	4 single-ended; synchronous
Sampling Frequency	Up to 160MSPS
Resolution	16-bits
Input Bandwidth	> 350MHz (all channels)
Analog Input Power	+6 dBm (+14dBm Max)
Input Impedance	50 Ohm, AC coupled
SNR	70.7 dBFS (10.7MHz @ 160MSPS)
SINAD	69.6 dBFS (10.7MHz @ 160MSPS)
SFDR	88.5 dBc (10.7MHz @ 160MSPS)
ENOB	11.3-bits (10.7MHz @ 160MSPS)
Clock & Trigger Inputs	
External	Front panel SMC
Input Level (Max)	6 dBm
Sample Frequency Range	1 to 160MSPS
Input Impedance	50 Ohm, AC coupled
Trigger Input/Output	TTL Single-ended, 10k Ohm impedance

PCI	
PCI Compliance	32/64-bit PCI 33/66MHz, PCI-X 66/100/133MHz, Master/slave/DMA, Interrupt support
PMC User I/O	32 LVDS signals (8 per bank). 2.5V signaling
Software/HDL Code	
Host Drivers	Wind River VxWorks 6.x, Wind River Linux
FDK	Analog input, memory interfaces, local bus
Miscellaneous	
Typical Power Consumption	31W

Table 2: Ordering Information

PMC-E2202-CT0400zz		
Part Number	Description	
C	Cooling: Air- or Conduction-cooled (A/C)	
T	Temperature Range	0 = L0
		1 = L100 (contact factory for availability)
		2 = L200 (contact factory for availability)
04	4 Input Channels	
zz	Product Specific Variants	



Table 3: Specifications

Part number extension		Air-cooled			Conduction-cooled	
		Level 0	Level 100	Level 200 (Note 6)	Level 100	Level 200
Temperature	Operational (Air-cooled Note 4) (Conduction-cooled Note 7)	0°C to +50°C	-40°C to +71°C	-40°C to +85°C	-40°C to +71°C	-40°C to +85°C
	Non-operational (storage)	-40°C to +85°C	-55°C to +125°C	-55°C to +125°C	-55°C to +125°C	-55°C to +125°C
Vibration	Sine (Note 1)	2g peak 15-2k Hz	10g peak 15-2k Hz	10g peak 15-2k Hz	10g peak 15-2k Hz	10g peak 15-2k Hz
	Random (Note 2)	0.01g2/Hz 15-2k Hz	0.04g2/Hz 15-2k Hz	0.04g2/Hz 15-2k Hz	0.1g2/Hz 15-2k Hz	0.1g2/Hz 15-2k Hz
Shock (Note 3)	Operational	20g peak	30g peak	30g peak	40g peak	40g peak
Humidity	Operational	0-95% non-condensing	0-100% non-condensing	0-100% non-condensing	0-100% non-condensing	0-100% non-condensing
	Non-operational (storage)	0-95% non-condensing	0-100% condensing	0-100% condensing	0-100% condensing	0-100% condensing
Conformal Coat (Note 5)		No	Yes	Yes	Yes	Yes

Notes:

1. Sine vibration based on a sine sweep duration of 10 minutes per axis in each of three mutually perpendicular axes. May be displacement limited from 15 to 44Hz, depending on specific test equipment.
2. Random vibration 60 minutes per axis, in each of three mutually perpendicular axes.
3. Three hits in each axis, both directions, 1/2 sine and saw tooth. Total 36 hits.
4. Standard airflow is 8 cfm at sea level. Some higher-powered products may require additional airflow. Consult the factory for details.
5. Conformal coating type is manufacturing site specific. Consult the factory for details.
6. This is a non-standard product. Consult factory for availability.
7. Temperature is measured at the card edge.

Warranty

This product has a one year warranty.

Contact Information

To find your appropriate sales representative, please visit:

Website: www.cwembedded.com/sales

Email: sales@cwembedded.com

Technical Support

For technical support, please visit:

Website: www.cwembedded.com/support1

Email: support1@cwembedded.com

The information in this document is subject to change without notice and should not be construed as a commitment by Curtiss-Wright Controls Embedded Computing. While reasonable precautions have been taken, Curtiss-Wright Controls assumes no responsibility for any errors that may appear in this document. All products shown or mentioned are trademarks or registered trademarks of their respective owners.