

General Standards Corporation

High Performance Bus Interface Solutions

PMC-DIO24

High-speed Parallel Digital I/O PMC Board

UNITRONIX Pty Ltd

PO Box 486, Morisset NSW 2264

NSW: Tel: 61 2 4977 3511 Fax: 61 2 4977 3522

WA: Tel: 61 8 9455 2424 Fax: 61 8 9455 2458

unitsyd@unitronix.com.au www.unitronix.com.au

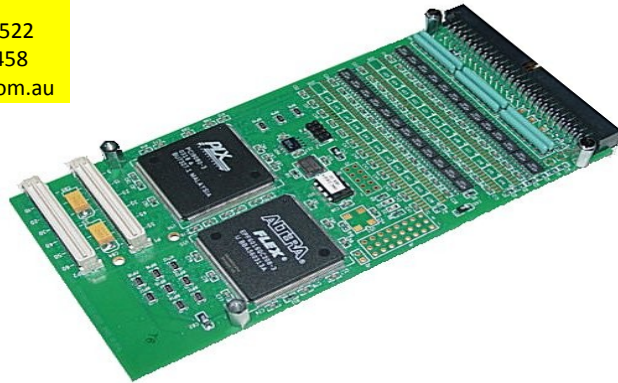

Features Include:

- Data input/output width of 24 bits.
- RS422/485 differential I/O transceivers or ECL differential I/O transceivers.
- 50 pin front panel connector for easy access via twisted pair ribbon cable.
- A single board can interface to a wide variety of external high-speed devices.
- Flexibility for custom protocols is provided by a Field Programmable Gate Array (FPGA).
- 32-Bit data transfers at 33 MHz on the PCI bus.
- 132 Mbytes per second PCI transfer rate in burst mode.
- Windows 2000 and NT drivers available with sample code.

Applications Include:

- ✓ Data acquisition and control.
- ✓ General Purpose Parallel Input / Output interface.
- ✓ Development and research.

Overview:

The DIO24 is a 24-bit discrete I/O interface board. The host side connection is PCI based and the external I/O interface is accessible through a 50 pin connector. The external interface includes 24 signals that can be arbitrarily programmed as either input or output. The 24 programmable signals are divided into three groups of eight signals each; Port A, Port B and Port C. Port A and B signals are each programmable as all inputs or all outputs. The Port C signals are individually programmable as input or output. One extra signal can be configured to generate an external clock or used as an additional input.

General Standards Corporation

8302A Whitesburg Drive - Huntsville, AL 35802

Phone: (256)880-8787 or (800)653-9970

FAX: (256)880-8788

Email: sales@generalstandards.com

General Standards Corporation

High Performance Bus Interface Solutions

Custom Applications

Although the DIO24 provides extensive flexibility to accommodate many user applications, custom interfaces exist which may not conform to current DIO24 interface options. General Standards Corporation has worked with many customers to provide customized versions of the DIO24 and other GSC products.

Custom protocols are implemented in an Altera FPGA. Previous custom applications implemented in FPGAs included features for counting pulses, incremental encoders, interrupt generation, special waveform generation, DMA, and many others. Modifications to existing FPGA firmware can be made by General Standards or by the customer if desired. Some other products have been implemented with Xilinx FPGAs and if necessary, a Xilinx version of the board could be developed. Please consult our sales department with your specifications to inquire about a custom application.

RS485/422 or ECL Interface

The standard interface option utilizes RS422/485 differential I/O transceivers. A version of the PMC-DIO24 is also available with ECL differential I/O transceivers.

SPECIFICATIONS

PCI INTERFACE

- Compatibility:** Conforms to PCI Specification 2.1.
Supports "plug-n-play" initialization.

MECHANICAL AND ENVIRONMENTAL

Power Requirements

+5.0 VDC \pm 0.20 VDC at 2.0 Amps, maximum

Physical Dimensions (Excluding panel bracket)

Height: 13.5 mm (0.53 in)

Depth: 149.0 mm (5.87 in)

Width: 74.0 mm (2.91 in)

Environmental Specifications

Ambient Temperature Range:	Operating: 0 to +55 degrees Celsius Storage: -40 to +85 degrees Celsius
Relative Humidity:	Operating: 0 to 80%, non-condensing Storage: 0 to 95%, non-condensing
Altitude:	Operation to 10,000 ft.

General Standards Corporation

High Performance Bus Interface Solutions

❑ **Cooling Requirements** 200 LFPM minimum air flow across component side of board.

ORDERING INFORMATION

The DIO24 is designed to fit a variety of high-speed digital interface needs and has several options that must be specified when being ordered. Please consult our sales department with your application requirements in order to determine the correct ordering options.

SYSTEM I/O CONNECTIONS

System Connector Pin Functions

Pin No.	Cable Signal Name
1	PORT A D0 +
2	PORT A D0 -
3	PORT A D1 +
4	PORT A D1 -
5	PORT A D2 +
6	PORT A D2 -
7	PORT A D3 +
8	PORT A D3 -
9	PORT A D4 +
10	PORT A D4 -
11	PORT A D5 +
12	PORT A D5 -
13	PORT A D6 +
14	PORT A D6 -
15	PORT A D7 +
16	PORT A D7 -
17	PORT B D0 +
18	PORT B D0 -
19	PORT B D1 +
20	PORT B D1 -
21	PORT B D2 +
22	PORT B D2 -
23	PORT B D3 +
24	PORT B D3 -
25	PORT B D4 +

Pin No.	Cable Signal Name
26	PORT B D4 -
27	PORT B D5 +
28	PORT B D5 -
29	PORT B D6 +
30	PORT B D6 -
31	PORT B D7 +
32	PORT B D7 -
33	PORT C D0 +
34	PORT C D0 -
35	PORT C D1 +
36	PORT C D1 -
37	PORT C D2 +
38	PORT C D2 -
39	PORT C D3 +
40	PORT C D3 -
41	PORT C D4 +
42	PORT C D4 -
43	PORT C D5 +
44	PORT C D5 -
45	PORT C D6 +
46	PORT C D6 -
47	PORT C D7 +
48	PORT C D7 -
49	Dedicated INPUT +
50	Dedicated INPUT -

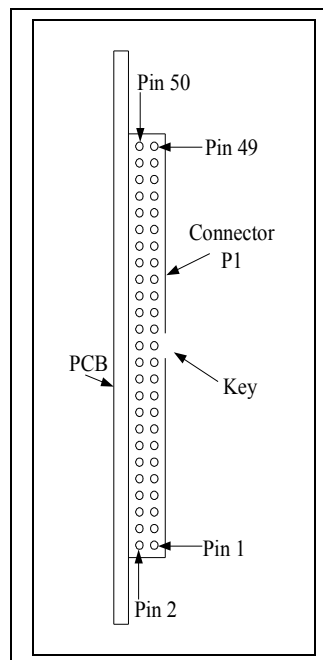

The connector mounted on the board is manufactured by Tyco and has the part number AMP 1-103311-0. The part number of the mating connector is AMP 1-746285.

General Standards Corporation assumes no responsibility for the use of any circuits in this product. No circuit patent licenses are implied. Information included herein supersedes previously published specifications on this product and is subject to change without notice.