

# FlexATX PrPMC Development Platform

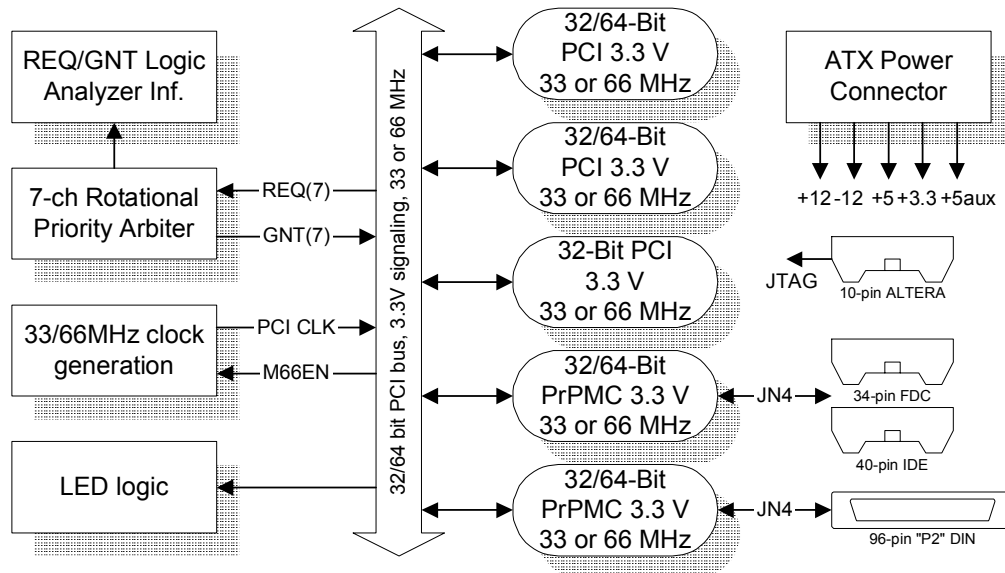

The FlexATX Development Platform provides two PrPMC and three edge-finger PCI bus slots in a standard 9"x7.5" form-factor used in Personal Computer ATX enclosures.

One of the two PrPMC slots must be populated with a Processor PMC (Vita 32) and a jumper on the ATX carrier selects monarch mode. The other PrPMC site can be depopulated, populated with a standard PMC (IEEE 1386.1), or populated with a second PrPMC operating in non-monarch mode.

The board supports a 64-bit PCI bus connection between all the bus members, except for one of the PCI edge finger slots which supports 32-bits. All slots are keyed for 3.3V signaling (5V signaling is NOT supported). The bus will run at 66 MHz if all the populated PCI bus devices assert "M66EN", or at 33 MHz if any one of the populated PCI bus devices has M66EN tied to GND.

A 34-pin Floppy Disk connector (JP2) and a 40-pin IDE connector (JP1) are wired to PrPMC slot A rear I/O for use with the Technobox P/N 3797 GEODE™ Processor PMC. This slot may be used for other PrPMCs as well if the Rear I/O is not used. A PrPMC populated in Slot B connects to a 96-pin DIN connector (JV1), mimicking connection to the P2 connector of a VMEbus board per the IEEE 1386 recommendations.

Fans located under the PrPMC slots provide forced air cooling. The fans blow air out the side for efficient non-stalling transport of air at about 4 cubic ft/min.

A 7-channel rotational priority circuit arbitrates the REQ signals coming from the PCI devices and issues GNT signals accordingly. The arbiter provides overlapped

arbitration, and the last successful member granted the bus becomes the lowest priority device for the next arbitration cycle. Note that each PrPMC requires two REQ/GNT pairs in order to service the PrPMC primary and secondary PCI devices. A logic analyzer header allows observation of the REQ/GNT activity.

LED logic decodes the PCI bus command field to illuminate LEDs for Memory, Configuration, and I/O accesses. Pulse stretching is used to power LEDs for infrequent events. Other LEDs monitor power, PCI Interrupt, and bus mastering slot activity.

For LEDs located on the cabinet, a header is provided to drive the Activity LED (PCI bus activity in this implementation) and Power LEDs. The Power Switch and Hard Reset buttons are also supported.

For JTAG support, the circuit will electronically bypass depopulated slots to preserve the TDI-TDO chain. The JTAG terminates in a 10-pin header pinned for ALTERA ByteBlasterMV applications (3.3V). This facilitates in-circuit programming of user circuits on the PCI plug-in modules.

Power is provided to the board via a standard 20-pin ATX power supply connector. A linear regulator powers the +3.3aux rail to the PCI and PrPMC slots from the ATX +5Vaux supply.

This board has been carefully designed using an 8-layer PCB, with 4 signal layers and 4 power planes. PCI signals are controlled at 75 ohms. The PCI clocks are routed with equidistant paths. These practices assist in supporting operation at 66 MHz.

# FlexATX PrPMC Development Platform

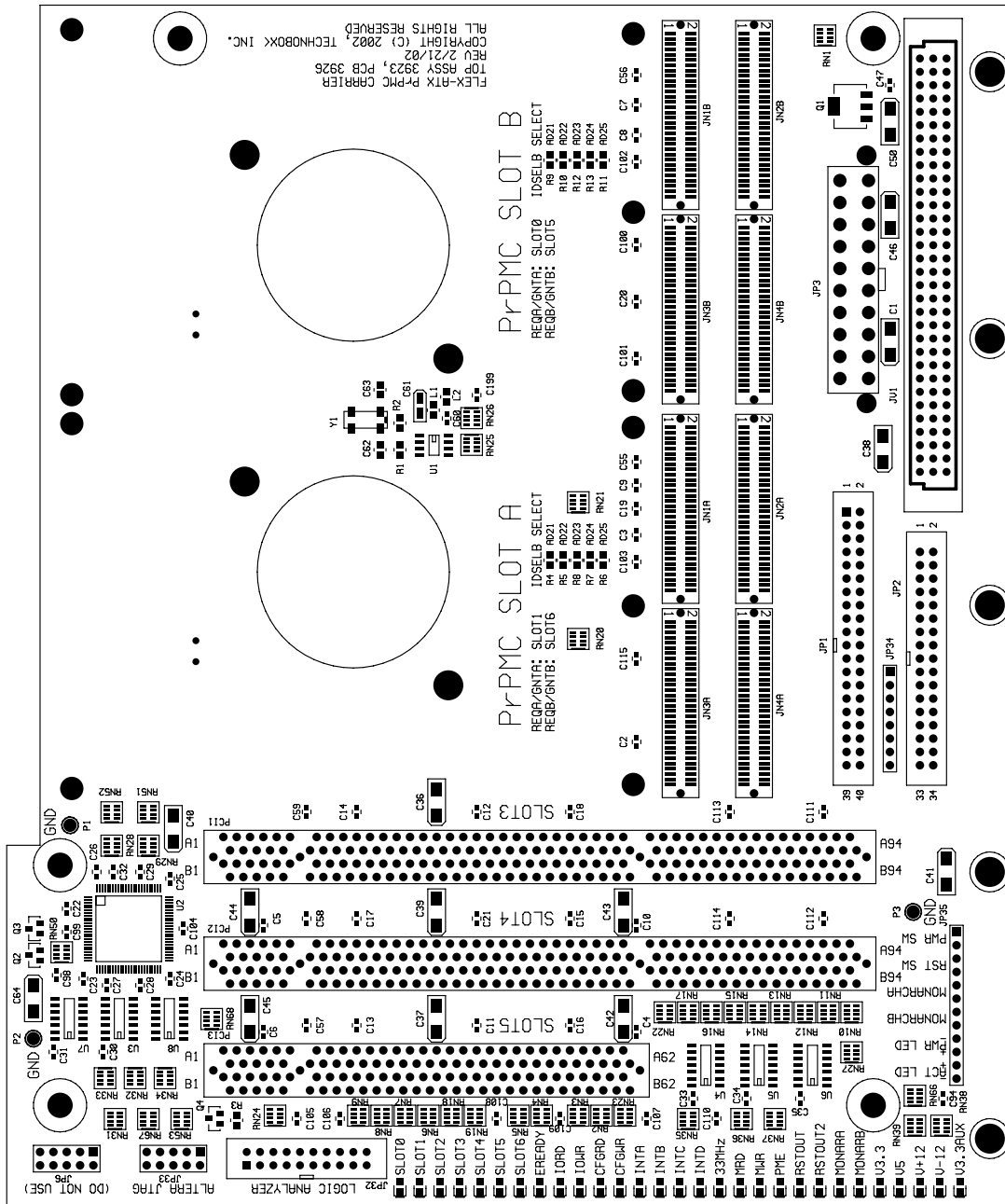

## Product Summary

Technobox Part Number:	3923 (PC cabinet, Power supply, peripherals purchased separately)
Typical Power Dissipation:	N/A
Power Supplies Required:	Per ATX Standard (+12, -12, +5, +3.3, +5aux)
PCI Signaling Environment:	3.3 Volt only, 33-/66-MHz, 32-/64-bit

**UNITRONIX Pty Ltd**

PO Box 486, Morisset NSW 2264

NSW: Tel: 61 2 4977 3511 Fax: 61 2 4977 3522

WA: Tel: 61 8 9455 2424 Fax: 61 8 9455 2458

unitsyd@unitronix.com.au www.unitronix.com.au