

55J1

28 Vin DC/DC Converter

50 Watt Single & Dual Outputs

Features



- High Power Density, Low Profile Packaging
- Full Output Power at +100°C Baseplate Temperature
- Switching Power Supply – Low Noise
- ESS Screening
- Designed and Manufactured Per NAVMAT Guidelines
- EMI Filtering Designed to MIL-STD-461
- Remote Error Sensing
- Remote Digital (TTL) Turn On/Off
- Transient Protection per MIL-STD-704

Contents

Specifications.....	1
Electrical.....	1
Physical/Environmental.....	2
Output Power (Table 1).....	2
Pinout Designations (J1) (Table 2).....	2
Connector Specifications.....	2
Output Wiring Diagram.....	3
Mechanical Layout.....	3
Mechanical Dimensions (Table 3).....	4
Ordering Information.....	4

Description

North Atlantic Industries 55J1 is a high power density, low profile, DC/DC Converter in 50 Watt single & dual output configurations. The 55J1 is ideally suited for rugged, military conduction cooled applications. All North Atlantic Industries DC/DC Converters are designed and qualified to the most stringent performance and environmental requirements.

Electrical Specifications

DC Input Characteristics:

Input	16 to 36 VDC; 40 VDC maximum with no damage (50 VDC maximum – Optional)
EMI/RFI Characteristics	Designed to meet the requirements of MIL-STD-461D; CE102
Input Transient Protection	Per MIL-STD-704D

DC Output Characteristics:

Output Power	50 Watts, See Table 1
Output Voltage	5 VDC to 28 VDC, See Table 1
Efficiency	72% minimum
Line Regulation	Within 0.1% for low to high line changes at constant load
Load Regulation	0.1% for 0 to 100% of rated load at nominal input line
PARD (Noise and Ripple)	50 mV p-p typical; 100 mV p-p maximum for 5V outputs (20 MHz bandwidth); 1% of the output voltage, with a maximum of 200 mV p-p, for all other outputs (20 MHz bandwidth)
Load Transient Recovery	Output voltage returns to regulation limits within 0.5 msec (typical), half to full load
Load Transient Under/Overshoot	0.35 Volt maximum from nominal output voltage set point for 3.3 V and 5.0 V outputs, all other outputs are 5%.

DC Output Characteristics (Continued):

Short Circuit Protection	Under any short circuit condition, output voltage drops to less than 1 volt, with automatic recovery
Current Limiting	120% ±10% typical
Over Voltage Protection	Automatic electronic shutdown if voltage exceeds 125% ±10% (Single Output); Dual output units protected against mis-wired sense lines.
Remote Error Sensing	Compensates for up to 0.5-volt drop on output leads
Remote Turn On/Off	TTL logic 1 inhibits (turns off) the output; a floating input acts as a logic 0 (output on)
Isolation Voltage	500 VDC input to output and input to case; 100 VDC output to case.
Insulation Resistance	50 Megohm at 50 VDC

Physical/Environmental Specifications

Temperature Range	Operating: -55°C to +100°C at 100% load (Temperature measured at baseplate; conduction via baseplate only); Storage: -55°C to +125°C
Temperature Coefficient	0.01% per °C
Shock	30 G's each axis, per MIL-STD-810C, Method 516.2, Procedure 1. Hammer shock per MIL-S-901C
Acceleration	6 G's per MIL-STD-810C, Method 513.2, Procedure 11, and 14 G's per Procedure 1
Vibration	Per MIL-STD-810C, Method 514.2, Procedure 1A
Reliability	(MTBF) 200,000 hours, ground benign, at 50°C baseplate
Humidity	95% at 71°C per MIL-STD-810C, Method 507.1 (non-condensing)
Altitude	40,000 feet per MIL-STD-810C, Method 504.1, Category 6 Equipment
Dimensions	See Table 3
Salt Fog	Per MIL-STD-810C, Method 509.1
Sand/Dust/Fungus	Per MIL-STD-810C
Enclosure	Aluminum housing to aluminum baseplate
Finish	Cover: Black anodized; Baseplate: chemfilm
Interface	Connections via a D-subminiature connector per Page 2 of this Data Sheet
Weight	Single Output = 9 ounces; Dual Output = 10 ounces

Table 1. Output Power

Single		Dual	
Volts	Amps	Volts	Amps
5.0	10.0	±5.0	5.0
6.5	7.6	±12.0	2.1
12.0	4.2	±15.0	1.7
15.0	3.4		
24.0	2.1		
28.0	1.8		

Table 2. Pinout Designations (J1)

Pin	Single	Dual	Pin	Single	Dual
1	+INPUT	-INPUT	9	-INPUT	+INPUT
2	+INPUT	N/C	10	-INPUT	N/C
3	-TTL (ON/OFF)	-TTL (ON/OFF)	11	CHAS GND	CHAS GND
4	+TTL (ON/OFF)	+TTL (ON/OFF)	12	+SENSE	-SENSE 1*
5	+OUTPUT	+SENSE 1*	13	-SENSE	-OUTPUT 1*
6	+OUTPUT	+OUTPUT 1*	14	+OUTPUT	-SENSE 2*
7	-OUTPUT	+SENSE 2*	15	-OUTPUT	-OUTPUT 2*
8	-OUTPUT	+OUTPUT 2*			

*note: for dual output versions refer to specific code on the code table for description of which output is # 1 and which is # 2

Connector Specifications

Connector	Part Number - Series
Unit Connector	DAMME15PR
Mating Connector	DAMM15S

Output – Wiring Diagram

Single Output

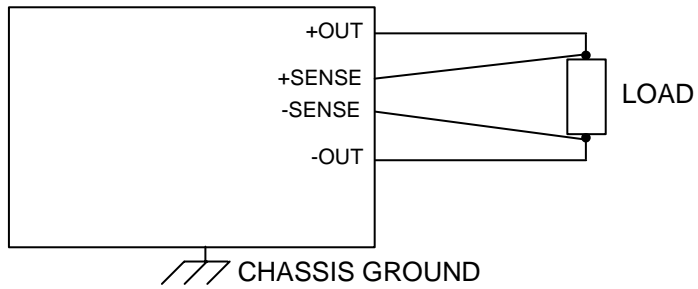

Dual Output

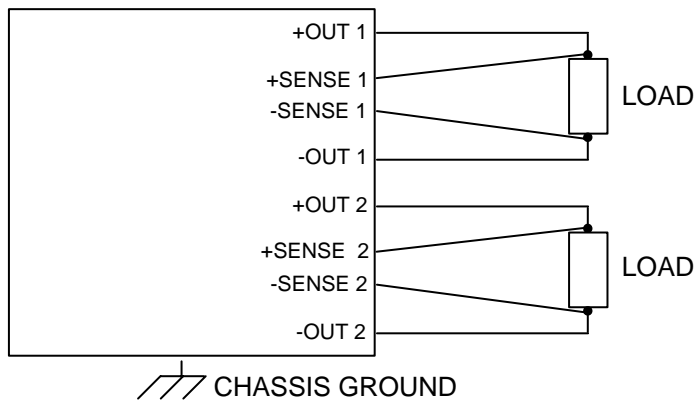

Mechanical Layout

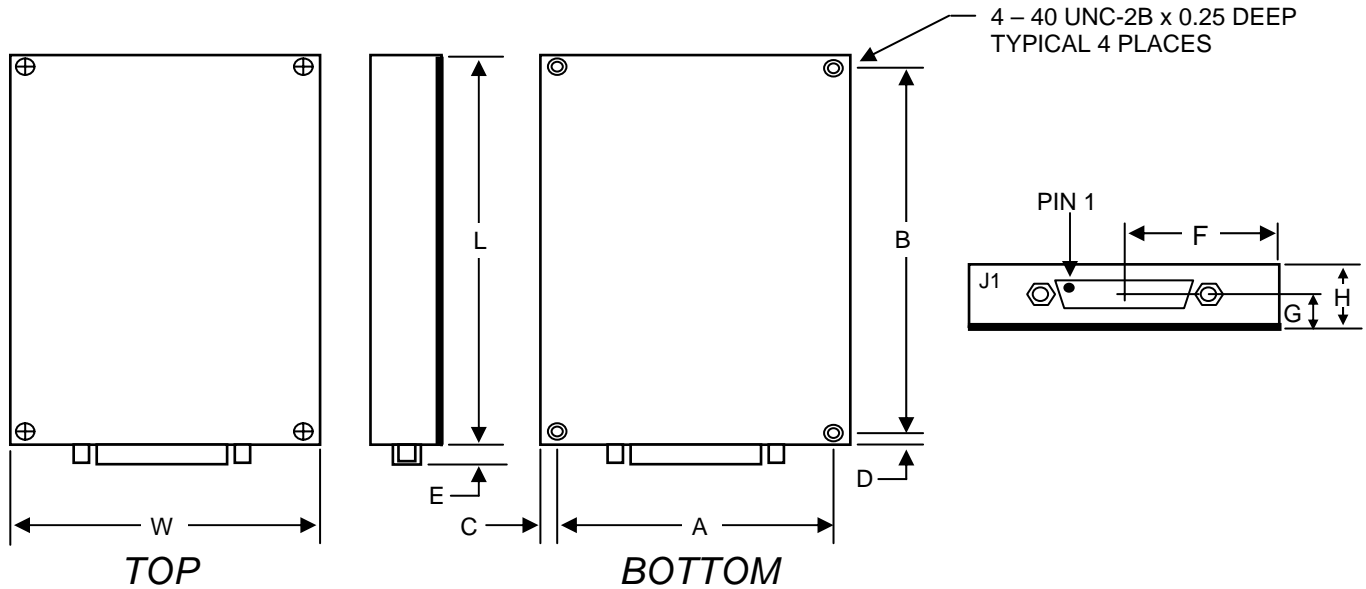

Mechanical Dimensions – See Table 3 (following)

Table 3. Mechanical Dimensions

Case*	Units	W	L	A	B	F
1	Inches	2.5	3.5	2.100	3.100	1.25
1	mm	63.5	88.9	53.34	78.74	31.8
2	Inches	3.00	3.85	2.600	3.450	1.50
2	mm	76.20	97.79	66.04	87.63	38.1

*Use Case 1 for Single Output Converter; Use Case 2 for Dual Output Converter

Notes

Dimensions C & D: 0.2" (5.1 mm)

Dimension E: 0.23" (5.84 mm)

Dimension G: 0.455" (11.56 mm)

Dimension H: 0.8" (20.3 mm)

Ordering Information for 55J01 Series (50 Watt DC/DC Converter)

55 J D1 - 005 M 0 - XX

CODE (Used only for "Specials") See Code Table Below

OPTIONS: 0 = Standard Testing (Includes ESS Temperature Cycling per NAVMAT)
 1 = Standard Testing plus ESS Vibration Testing (per NAVMAT)

RELIABILITY:

M = COTS-Mil-Type: -55°C to +100°C, Mil-Type Components, Designed to meet the Requirements of MIL-STD-461C, Designed to meet the requirements of MIL-STD-810C, Designed per NAVMAT Guidelines.

OUTPUT VOLTAGE(s): Single Output Dual Output

005 = 5 V	005 = ±5 V
006 = 6.5 V	012 = ±12 V
012 = 12V	015 = ±15 V
015 = 15 V	
024 = 24 V	
028 = 28 V	

000 = Special Voltage –
 See Code Table Below

OUTPUTS: S1 = Single
 D1 = Dual

WATTAGE: J = 50 W

SERIES: 55 = DC/DC (Low Voltage)

Example: 55JD1-012M0 = DC /DC (Low Voltage); 50 Watt; Dual Output; ±12 V; COTS-Mil-Type; Standard Testing

Consult Factory for Additional Options and/or Special Units

See Code Table next page

Code Table for "Specials"

Code	Code Description
01	Potted, Designed to meet Mil-Std-810C, Procedure 1, Category 6, 70,000 feet (Add 0.9 lbs to weight of unit)
02	Model # 55JD1-000M0-02. Dual Outputs as follows: Output # 1 = +12vdc @ 2.5amps Output # 2 = +5.2vdc @ 5amps
03	Model # 55JD1-000M0-03. Dual Outputs as follows: Output # 1 = +12vdc @ 2.5amps Output # 2 = +5.0vdc @ 5amps
04	55JS1-006M0 modified as follows: Output is +8vdc @ 6.25amps, potted with material to meet 1 meter immersion, 30 minutes, non-operating, 95% humidity. Configured with input/output cable per specified source control drawing. Cable is in lieu of "D" connector. Unit Part # is 55JS1-006M0-04
05	55JD1-000M1-05. Dual outputs as follows: Output # 1 = +28vdc @ 25 watts Output # 2 = +5vdc @ 25 watts Potted, Designed to meet Mil-Std-901, Grade B shock and Mil-Std 167, Type I vibration (Add approx. 0.9 lbs to weight of unit). Optional 100% vibration screening performed and unit includes thermal pad.
06	Model 55JS1-000M0-06. Standard 55JS1-024M0 modified to supply an output of 24vdc @ 1.1Amps for 30 seconds while the input voltage is at 11Vdc. Under normal conditions the input will be within 18 to 32Vdc.

UNITRONIX Pty Ltd

PO Box 486, Morisset NSW 2264

NSW: Tel: 61 2 4977 3511 Fax: 61 2 4977 3522

WA: Tel: 61 8 9455 2424 Fax: 61 8 9455 2458

unitsyd@unitronix.com.au www.unitronix.com.au

North Atlantic Industries, Inc.
110 Wilbur Place, Bohemia, NY 11716

631.567.1100/631.567.1823 (fax)
www.naii.com / e-mail:sales@naii.com

Cage Code:OVGU1

55J01A001 Rev M
Page 6 of 6