

55PQ2 DC-DC SERIES

- 28 Vin DC/DC Converter
- Up to 150 Watts
- Up to 4 Outputs, plus standby



Features

- High Power Density, Low Profile Packaging
- Wedglock Design
- Designed with component derating Per (NAVSO P3641)
- EMI Filtering Designed to MIL-STD-461E
- Remote Sensing
- Transient Protection per MIL-STD-704
- Standby output
- ANSI/VITA Signaling (*Optional*)
- Current Share (*Optional*)

Contents

Specifications.....	1
Electrical	1
Physical/Environmental.....	2
Input Pinouts (Table 1)	3
Output Pinouts (Table 2).....	3
Output Wiring Diagram	4
Mechanical Layout	5
Ordering Information	6
Tables 3 to 5 Output Power & Options	7

Description

NAI's 55PQ2 is a high power density, low profile, 28VIN DC/DC switch mode converter. This converter provides power up to 150 Watts with up to 5 outputs and addresses the power supply needs for **VME and cPCI systems**. The 55PQ2 is ideally suited for airborne, shipboard, ground mobile and C³I applications.

Electrical Specifications

DC Input Characteristics:

Input	16 to 36 VDC; 80 VDC maximum with no damage
EMI/RFI Characteristics	Designed to meet the requirements of MIL-STD-461E
Input Transient Protection	Per MIL-STD-704 A through D and MIL-STD-461E, CS106

DC Output Characteristics:

Output Power	Up to 150 Watts
Output Voltage	Quad outputs +3.3, +5,+/-12, ±15, +24 & +28vdc
Efficiency	70% Typical
Line Regulation	Within 0.1% for low to high line changes at constant load
Load Regulation	0.1% for 0 to 100% of rated load at nominal input line
PARD (Noise and Ripple)	50 mV p-p maximum (20 MHz bandwidth)
Load Transient Recovery	Output voltage returns to regulation limits within 0.5 msec (typical), half to full load
Load Transient Under/Overshoot	0.35 Volt maximum from nominal output voltage set point for 3.3 V and 5.0 V outputs, all other outputs are 5%.

Short Circuit Protection	Continuous Short circuit protection, with automatic recovery
Current Share <i>Optional</i>	Allows for increased system wattage or redundancy, by connecting 2 or more units

Signal Types (see ordering information section and Table # 4 to choose signal option sets):

Enable (standard on all versions)	$V_{IL} = 1V$ max, $V_{IH} = 3V$ min. Input has 1K Pull-down resistor. Floating or Low enables the switched outputs. High will disable the switched outputs.
DC Good (see option sets, table 4)	Open collector output capable of sinking 50 mA. Output will be low (conducting) when outputs are within 5% of nominal value
Power Fail Warning (PFW) (see option sets, table 4)	Open collector output capable of sinking 50 mA. Output will be low (conducting) when input is insufficient to produce full power
Over Current (OC) (see option sets, table 4)	Open collector output capable of sinking 50 mA. Output will be low (conducting) when outputs are not in over-current limit.
AC Fail (ANSI/VITA) Option Set 3, table 4	Signal from power supply indicating status of input
Sys Reset (ANSI/VITA) Option Set 3, table 4	Signal from power supply indicating reset (such as a power up) in progress
Reset (ANSI/VITA) Option Set 3, table 4	Input to power supply via switch; resets system without power off applied
Share OK Option Set 4, table 4	Signal from power supply which gives status during current share operation
Temperature Shutdown / Monitoring	via I ² C
Current Limiting	120% ±10% typical
OverVoltage Protection	Automatic electronic shutdown if voltage exceeds 125% ±10%
Remote Error Sensing	Compensates for up to 0.5-volt drop on +5v & 3.3v output leads
Remote Turn On/Off	TTL logic 1 inhibits (turns off) the output; a floating input acts as a logic 0 (output on)
Isolation Voltage	500 VDC input to output and input to case; 100 VDC output to case.
Insulation Resistance	50 Megohm at 50 VDC

Physical/Environmental Specifications

Temperature Range	Operating: -55°C to +85°C at 100% load (Temperature measured at card edge; conduction via card edge); Storage: -55°C to +125°C
Temperature Coefficient	0.01% per °C
Shock	30 G's each axis, per MIL-STD-810C, Method 516.2, Procedure 1. Hammer shock per MIL-S-901C
Acceleration	6 G's per MIL-STD-810C, Method 513.2, Procedure 11, and 14 G's per Procedure 1
Vibration	Per MIL-STD-810C, Method 514.2, Procedure 1A
Reliability (MTBF)	500,000 hours, ground benign, at 50°C baseplate
Humidity	95% at 71°C per MIL-STD-810C, Method 507.1 (non-condensing)
Altitude	50,000 feet per MIL-STD-810C, Method 504.1, Category 6 Equipment
Dimensions	See Mechanical Outline

Salt & Fog	Per MIL-STD-810C, Method 509.1
Sand/Dust/Fungus	Per MIL-STD-810C
Enclosure	Aluminum housing to aluminum baseplate
Finish	Chemfilm
Interface	Connections per Table 2
Weight	2 pounds max

Table 1. Input Connector Pin Designations (J1)

Signal	Pin(s)
+28vdc	4,5,6,12,13
+28vdc Return	7,8,14,15
Chassis Ground	1,2,9,10
N/C	3,11

Table 2. Output Connector Pin Designations (P2)

Signal	Pin(s)	Signal	Pin(s)
+5vdc	17,18,35,36,37	Over-Current / +5v current share / SCL (Opt 5) ^{*note}	7
Standby Out	19	+3.3v sense	4
+5v sense	16	+3.3vdc	1,2,3,20,21
Return	5,6,13,14,15,23,24,25,32,33	+5v sense rtn	34
-12v sense / -12v current share ^{*note}	12	-12v sense rtn / +12v current share ^{*note}	31
-12vdc	11,30	+12v sense	28
+12vdc	10,29	Converter enable	27
+12v sense rtn	9	DC Good / Share OK ^{*note}	26
Power fail warn / +3.3v current share / SDA (Opt 5) ^{*note}	8	+3.3v sense rtn	22

Note: For units with current share option, pin designations are per second signal name shown, for temperature shutdown option (5) use third name shown. Refer to Table 4, Option Sets.

Output Wiring Diagram

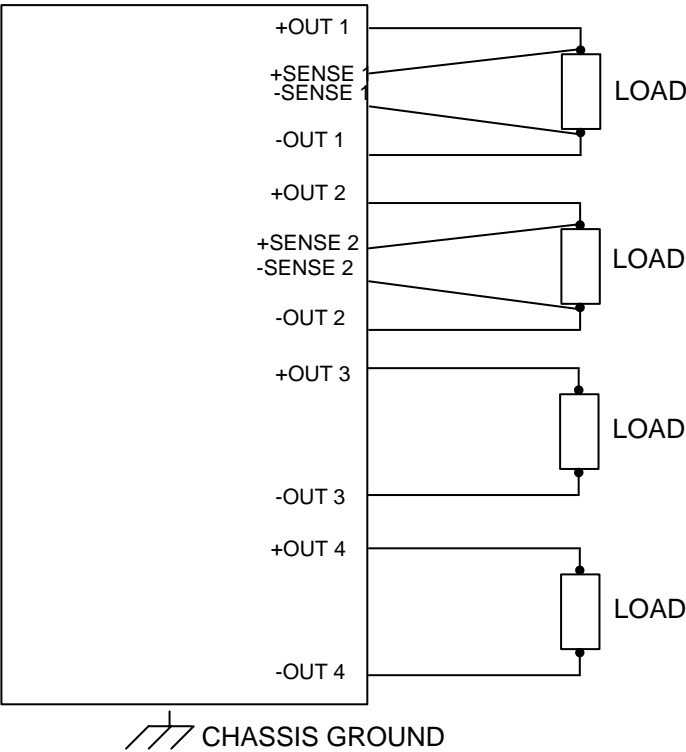

Mechanical Layout

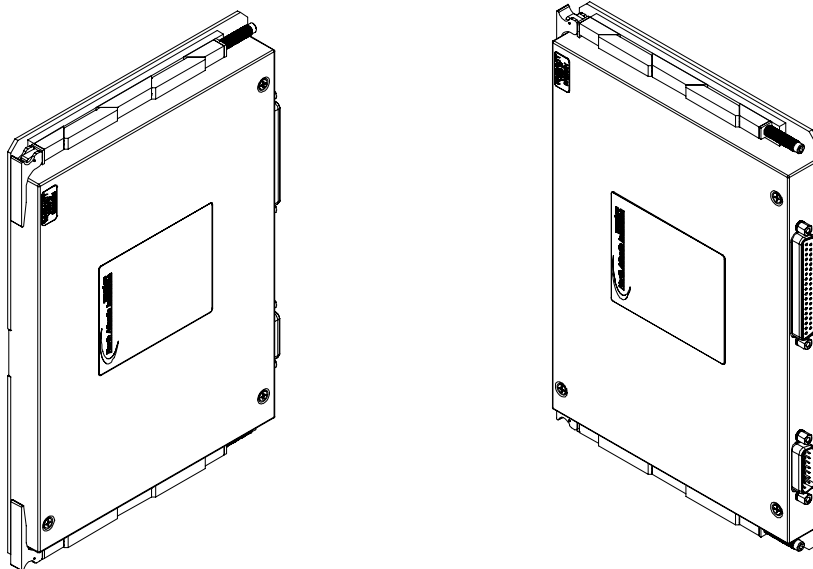
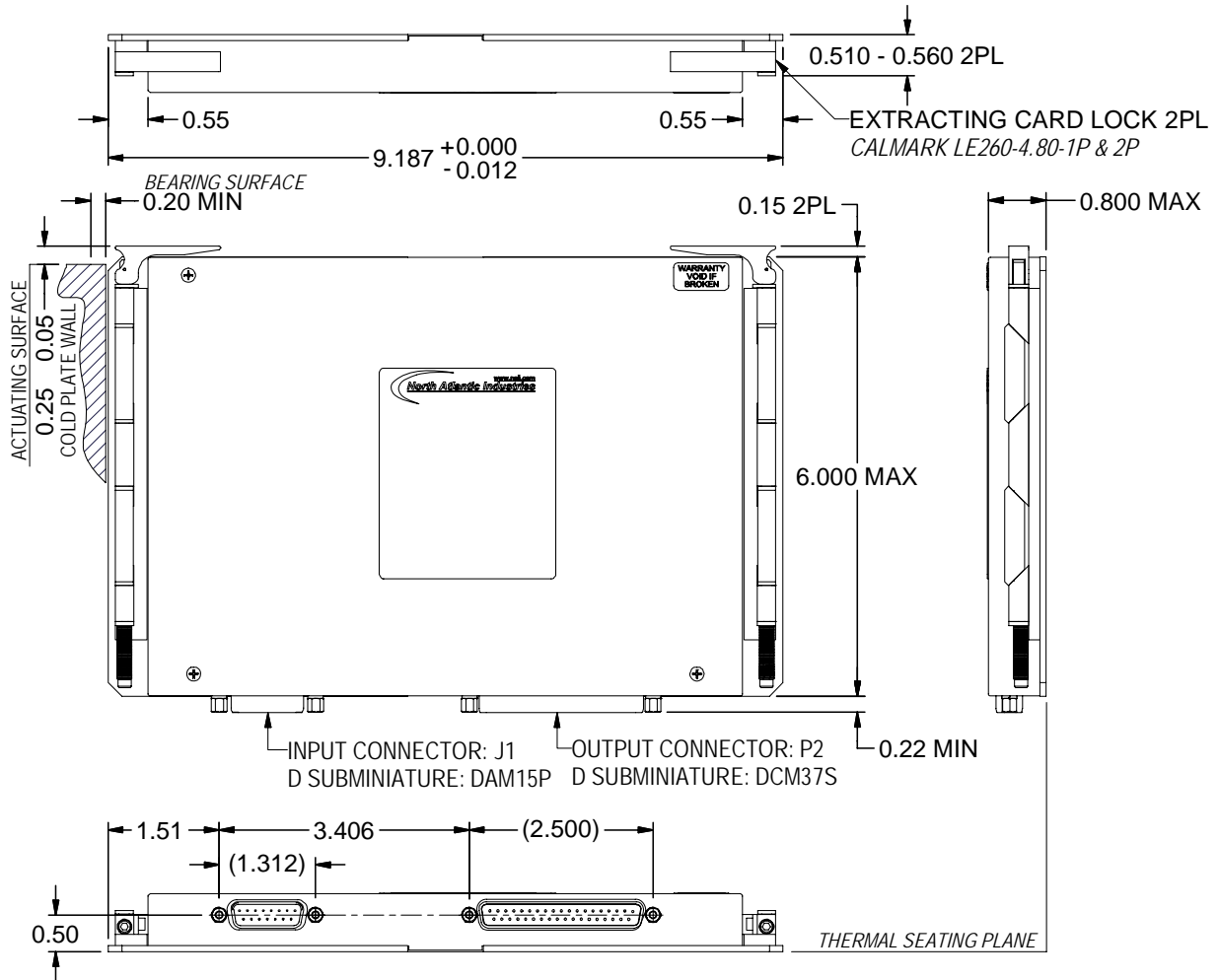

55PQ1_SBU-100
 4/5/06

Ordering Information for 55PQ2 (150 Watt DC/DC Converter)

For all Outputs,
refer to Table 3,
Output Power

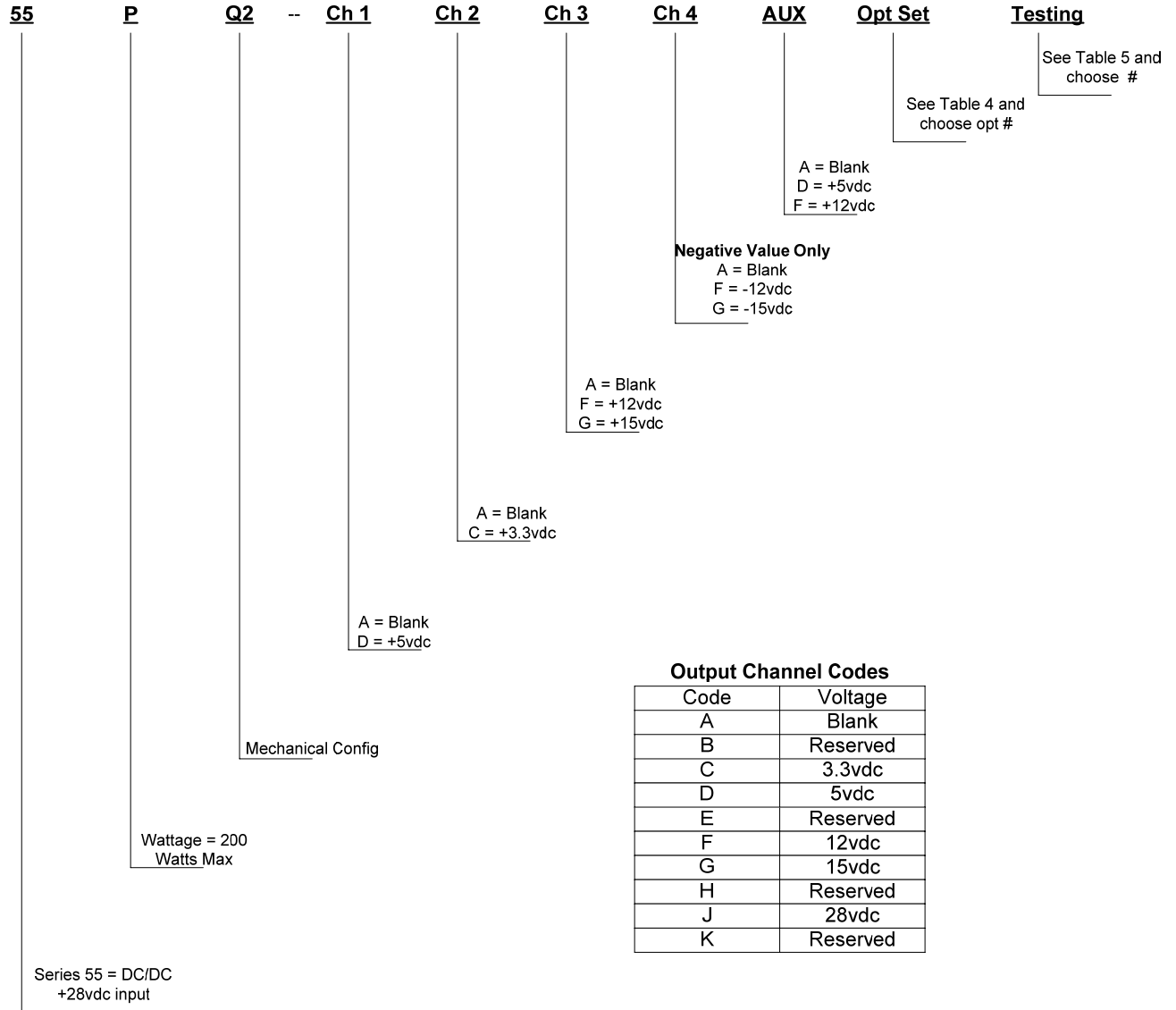

Output Channel Codes

Code	Voltage
A	Blank
B	Reserved
C	3.3vdc
D	5vdc
E	Reserved
F	12vdc
G	15vdc
H	Reserved
J	28vdc
K	Reserved

Refer to Tables 3 through 5 on next page

Examples:

Quad output unit with outputs of +5vdc, +3.3vdc, ±12vdc, Aux (standby) of +5vdc, option set 3 and standard testing:

Part number is 55PQ2-DCFFD30

Dual output unit with outputs of ±15, no Aux, option set 5 and optional testing

Part number is 55PQ2-AAGGA52

Table 3, Output Power

C1	C2	C3	C4	Aux	Total
50	40	24	24	5	143 watts

Table 4, Option Sets (refer to sheet 2 for signal descriptions)

Set #	Description
1	Standard, no additional options
2	Power Fail Warn (PFW), DC Good & OverCurrent
3	ANSI/VITA Signaling, includes AC Fail, Sys Reset & Reset
4	Current Share option, with Share OK Signal
5	Temperature monitoring & temperature shutdown when temperature reaches programmed limit (power on default 80°C) via I ² C bus using SCL and SDA signals. Unit also has DC Good Signal.
6	Current Share option, Share OK Signal (indicates DC output voltages and output current sharing is within tolerance).

Table 5, Testing Options

Option #	Description
0	Standard Testing, includes ESS Temperature cycling per NAVMAT
1	Optional Testing includes Standard Testing plus 100% vibration testing per NAVMAT

Consult Factory for Additional Options and/or Special Units

UNITRONIX Pty Ltd

PO Box 486, Morisset NSW 2264

NSW: Tel: 61 2 4977 3511 Fax: 61 2 4977 3522

WA: Tel: 61 8 9455 2424 Fax: 61 8 9455 2458

unitsyd@unitronix.com.au www.unitronix.com.au