

CASE STYLES

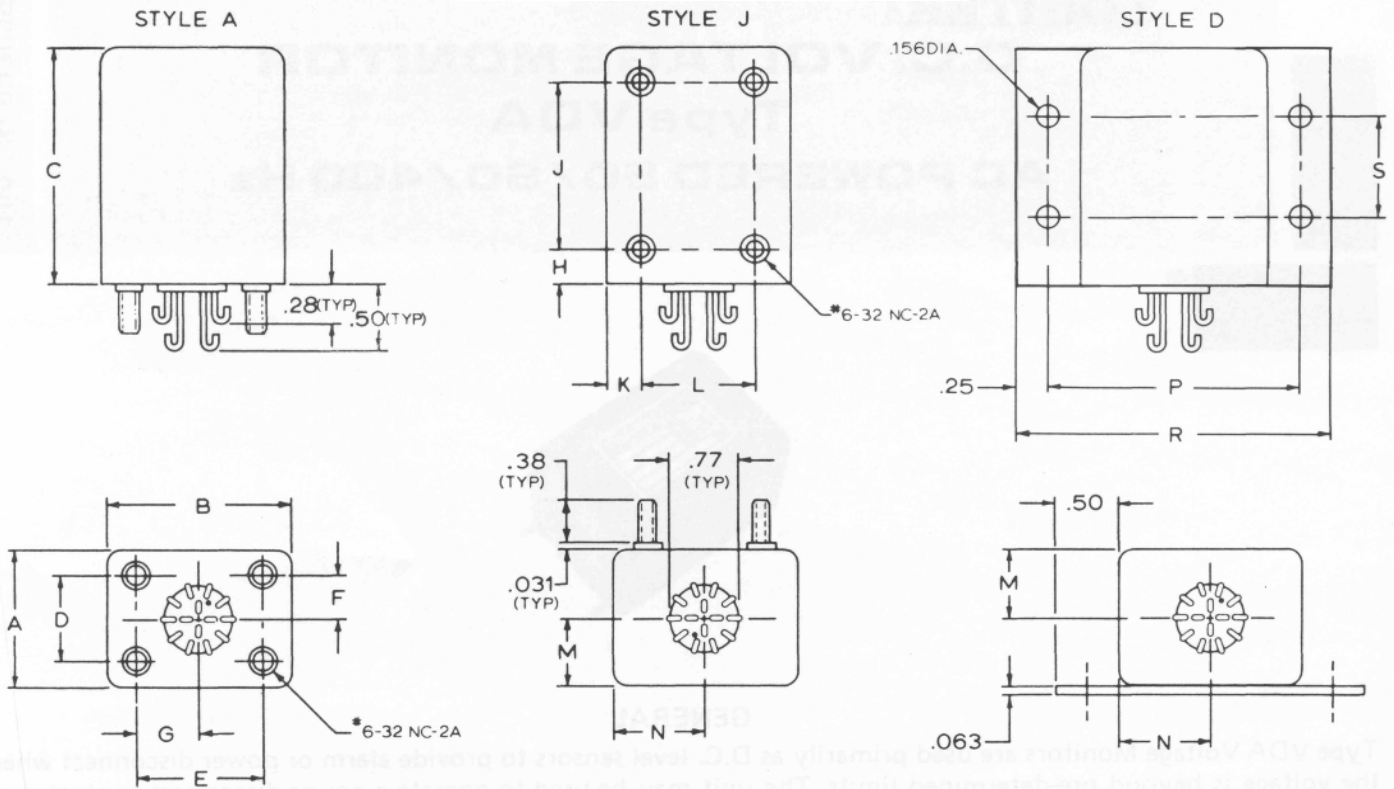

WIRING DIAGRAM

SYMBOL	
A	2.00
B	2.00
C	2.50
D	1.437
E	1.437
F	.718
G	.718
H	.31
J	1.875
K	.38
L	1.250
M	1.00
N	1.00
P	2.500
R	3.00
S	1.500

Tolerance .XXDEC ± .03 .XXX ± 0.010

ORDERING INFORMATION

To order, specify all parameter using the part numbering system shown below.

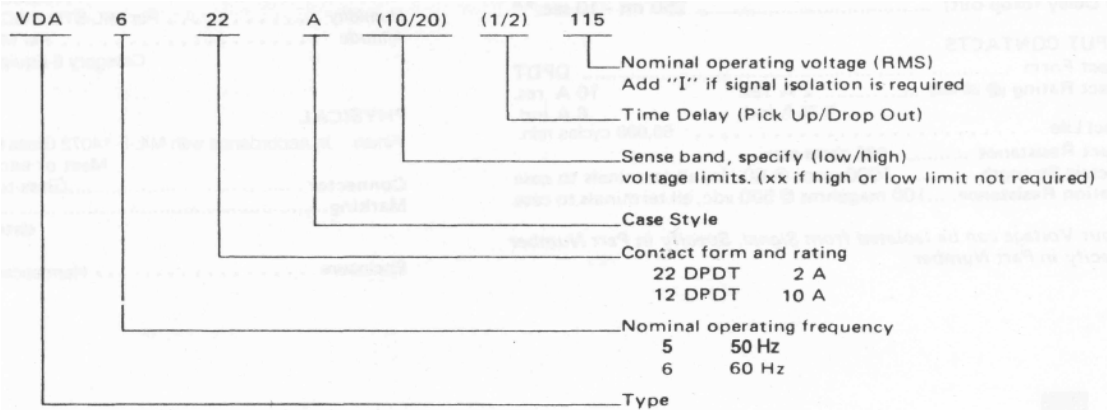

CASE DIMENSIONS

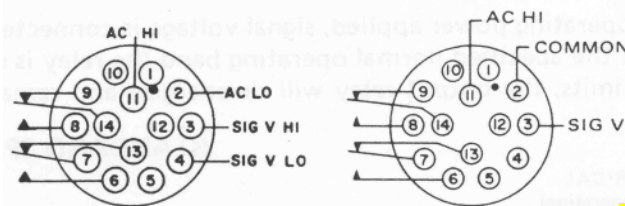

North Atlantic Industries, Inc.
110 Wilbur Place, Bohemia, NY 11716

631.567.1100/631.567.1823 (fax)
www.naii.com / e-mail:sales@naii.com

Cage Code:OVGU1

UNITRONIX Pty Ltd

PO Box 486, Morisset NSW 2264

NSW: Tel: 61 2 4977 3511 Fax: 61 2 4977 3522

WA: Tel: 61 8 9455 2424 Fax: 61 8 9455 2458

unitsyd@unitronix.com.au www.unitronix.com.au