



Data Sheet

VPX6-187 VPX

Single Board Computer



UNITRONIX Pty Ltd

PO Box 486, Morisset NSW 2264

NSW: Tel: 61 2 4977 3511 Fax: 61 2 4977 3522

WA: Tel: 61 8 9455 2424 Fax: 61 8 9455 2458

unitsyd@unitronix.com.au www.unitronix.com.au

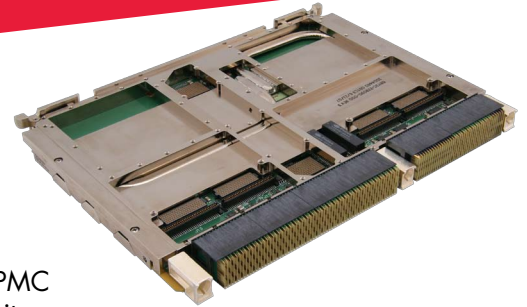

Features

- ◆ Freescale QorIQ™ P4080 up to 1.5GHz
 - Eight e500mc processor cores
 - Each core has 64KB L1 cache
 - Each core has 128MB L2 cache with ECC
 - Two DDR3 memory controllers with ECC
 - Four Gigabit Ethernet controllers
 - Two USB ports
 - Serial I/O controller
 - Two I2C channels
 - Three PCI Express® (PCIe) interfaces
 - One Serial RapidIO® (SRIO) interface
 - Integrated DMA controllers
- ◆ Up to 4GB DDR3 SDRAM with ECC
 - Dual-channel memory controllers
- ◆ 256 or 512MB Flash with write protection
- ◆ Permanent Alternate Boot Site (PABS) provides backup boot capability
- ◆ 512KB FRAM
- ◆ VITA 46 core fabric with both SRIO and PCIe interfaces
- ◆ OpenVPX Ready*
- ◆ Fabric Configurations
 - Four x4 SRIO interfaces up to 3.125GB/s, or two PCIe and two SRIO interfaces backwards compatible with the 185
 - Four x2 SRIO interfaces up to 3.125GB/s plus two x4 PCIe
- ◆ Four Gigabit Ethernet interfaces
 - 1 - Front panel - Standard product air-cooled only (configurable to backplane)
 - 3 - backplane - Option for dual 1000 BASEx
- ◆ Two XMC/ PMC mezzanine sites
 - One 133MHz PCI-X PMC or 8-lane PCIe XMC
 - One 8-lane PCIe XMC
- ◆ Four asynchronous EIA-232 serial ports
- ◆ Up to 4 HDLC/SDLC-capable sync/async EIA-232/422/485 serial channels
- ◆ Up to 14 LVTTTL discrete I/O signals
- ◆ Up to 16 EIA-422/485 differential discrete signals (eight inputs, eight outputs)
- ◆ Multi-board synchronous clock
- ◆ Two channel MIL-STD-1553 option
- ◆ Two channel Serial ATA (SATA) 1.0 option
- ◆ Two USB 2.0 ports
- ◆ Six general-purpose 32-bit timers in core functions FPGA
- ◆ Two 4-channel DMA engines
- ◆ Eight global timers organized as two groups of four in the P4080 Multicore Programmable Interface Controller (MPIC)
- ◆ Two avionics-style watchdog timers
- ◆ Real-time clock with VBAT switchover
- ◆ Six temperature sensors
- ◆ Supports 5V or 12V operation
- ◆ Continuum Software Architecture (CSA) firmware with extensive diagnostics
- ◆ VxWorks® 6.x Workbench® 3.x support
- ◆ WindRiver® Linux® 3.x
- ◆ Continuum Insights Multi-processor development tools
- ◆ Continuum IPC inter-processor communications
- ◆ Range of air- and conduction-cooled ruggedization levels available

* This product has been designed in accordance to the draft spec and should fit in selected OVPX backplane profiles, since the draft spec is still not formalized as an ANSI standard, things are subject to change.



Learn More

Web / sales.cwcembedded.com

Email / sales@cwembedded.com

**CURTISS
WRIGHT** Controls
Embedded Computing

Innovation In Motion.
cwembedded.com



Overview

The VPX6-187 is the next generation of modules from Curtiss-Wright Controls to employ the new open-architecture VITA 46 standard. VITA 46, also known as "VPX" was collaboratively developed by COTS industry leaders which included prime military integrators to marry high-speed serial interconnect such as SRIIO and PCIe. It is well suited to the military/aerospace which can take advantage of and utilize this form factor and feature set in their demanding applications. The VPX6-187 provides Single Board Computer (SBC) functionality to the Curtiss-Wright Controls VPX family that includes quad-processor DSP, FPGA accelerator and XMC/PMC carrier modules.

The VPX6-187 is based on Freescale's high-performance QorIQ P4080 SOC multi-core processor. Available in versions with up to eight Power Architecture Cores running at 1.5GHz, and up to 4GB of high-bandwidth DDR3 SRAM, the VPX6-187 provides high-performance processing, the massive 10GB/s bandwidth of VPX and a long list of

features and I/O interfaces to satisfy the most demanding requirements of embedded computing.

Available in a full range of environmental build grades, the VPX6-187 is targeted to the challenging data- and digital signal-processing needs of tactical aircraft, armored vehicles and harsh environment naval systems. For retrofit and technology insertion applications, the VPX6-187 offers a superset of the I/O features of earlier generations of Curtiss-Wright Controls VME 18x PowerPC™ SBCs. As a member of Curtiss-Wright Controls continuously evolving stream of PowerPC SBCs including the SVME/DMV-179, 181, 182, 183, 184, and the VPX6-185, the VPX6-187 supports the life-cycle model of successive technology insertions throughout a platform's lifetime.

The VPX6-187 will occupy a standard 0.8" slot and is also available in the VITA 48 (VPX RED1) format with covers to support two level maintenance LRM requirements. Air-cooled variants are delivered with 1" front panels.

Figure 1: VPX6-187 VPX Block Diagram

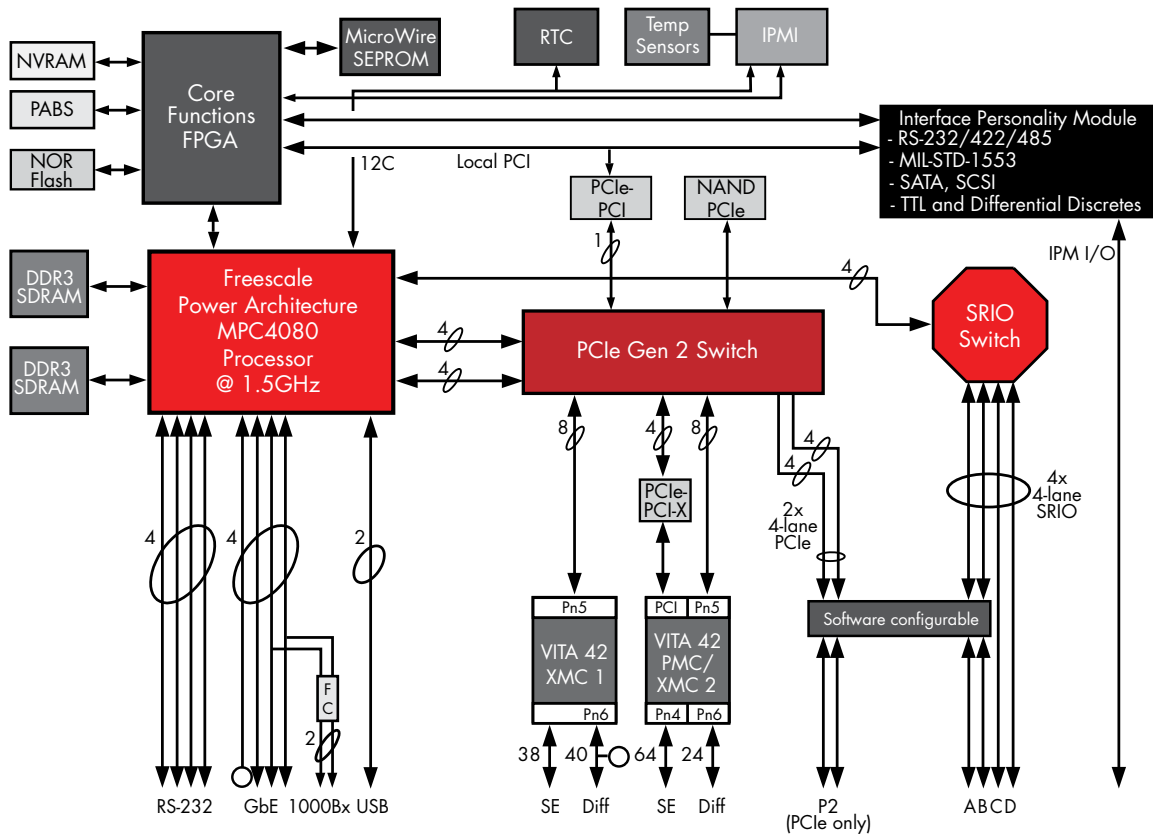



VPX Module Format

The Versatile Performance Switching (VPX) module format, governed by the VITA 46 specification and the associated VITA 48 Ruggedized Enhanced Design Implementation (REDI) was established to address the fundamental requirement to provide open-architecture modules that incorporate the high-speed serial interconnect technology that has become pervasive in high performance computing. The VPX standard was developed by the leading providers of military COTS modules to address the major issue of high-speed serial interconnect, as well as incorporating numerous improvements learned after years of integrating VME and CompactPCI (cPCI) modules. The VPX standard, in short provides:

- ♦ 3U and 6U Eurocard form factors preserve chassis mechanical designs
- ♦ Support four x4 serial interfaces as the primary fabric
- ♦ Support 128 differential pairs for modern high-speed interfaces such as DVI, SATA, SFPDP, SAS and custom sensor interfaces
- ♦ Optional support of VME for interoperability with legacy equipment
- ♦ Support of higher power modules and improved cooling
- ♦ Improved logistics with two-level maintenance and keying

The VPX module format provides many benefits to integrators of high-performance multi-processor systems for RADAR, electro-optical and signal intelligence applications. In particular SRIO is suited to high-bandwidth communications between processors in a VPX system, while PCIe functions as a fast connection between processors and the new generation of XMC modules which can easily be placed on VPX format carrier cards.

Eight Core Power Architecture Freescale QorIQ P4080 PowerPC

The processing function of the VPX6-187 is provided by the QorIQ P4080. The P4080 SOC includes the following function and features:

- ♦ Eight e500mc Power Architecture cores, each with a backside 128KB L2 Cache with ECC
 - 3 levels of instructions: User, Supervisor, and Ultravisor
 - Independent boot and reset
 - Secure boot capability
- ♦ Dual front side 1MB L3 Caches with ECC. One associated with each memory controller
- ♦ CoreNet bridges between the CoreNet fabric the I/Os, datapath accelerators, and high and low-speed peripheral interfaces
- ♦ Two 10GbE (XAUI) controllers
- ♦ Eight 1GbE controllers
- ♦ Two 64-byte DDR2/DDR3 SDRAM memory controllers with ECC
- ♦ Multi-core Programmable Interrupt Controller
- ♦ Four I2C controllers
- ♦ Four 2-pin UARTs
- ♦ Two 4-channel DMA engines
- ♦ Enhanced local bus controller (eLBC)
- ♦ Three PCIe 2.0 controllers/ports
- ♦ Two SRIO 1.2 controllers/ports
- ♦ Datapath Acceleration Architecture incorporating acceleration for the following functions
 - Packet Parsing, classification, and distribution
 - Queue Management for scheduling, packet sequencing, and congestion management
 - Hardware Buffer Management for buffer allocation and de-allocation
 - Encryption/decryption (SEC 4.0)
 - Regex Pattern Matching (PME 2.0)



Table 1 compares the key characteristics (and performance gains) of the P4080 to the previous generation VPX6-185 SBC based on the MPC864x processor.

Table 1: VPX6-187 to VPX6-185 Comparison

	185	187
Processor	Single MPC8641D	Single P4080
Number Cores	2x E600 cores @ 1.2GHz	8x E500mc @ 1.5GHz
Memory banks	x2, DDR2 at 500MHz	x2, DDR3 at 1066MHz
Memory bandwidth	8.6GB/s (DDR266)	17.05GB/s (DDR533)
DDR (read latency) (TS to TA)	~55ns	-
I/O fabric	4x SRIO or 2x SRIO, 2x PCIe	4x SRIO or 2x SRIO, 2x PCIe or 4x SRIO + 2x PCIe
XMC Sites	1 x8 PCIe + 1 x4 PCIe	2 x8 PCIe
PMC Sites	2 PCI-X	1x PCI-x
I/O Routing		
XMC/PMC Site	P64S + X12D	P64S + X12D
XMC Sites	-	X8D + 12D + 38S

VPX Fabric Interface

The VPX6-187 provides users with the option of using either SRIO or PCIe interfaces to connect with other VPX cards in a system be they payload or expansion cards. SRIO is suited for processor to processor or payload to payload communications and would be used to build a system with the VPX6-185, VPX6-187, CHAMP-AV6 and CHAMP-FX2 family of VPX products. PCIe is suited to connecting with PCIe and PCI-based peripheral devices. PCIe interfaces are designed to run at either 2.5GHz or 5GHz dependent on the pinout variant. SRIOs communicate at 3.125GHz. The VPX-187 makes use of its PCIe fabric interfaces to support the VPX6-215 ExpressReach XMC/PMC carrier card. The ExpressReach allows users to easily add extra XMC/PMC modules into a system by extending the local PCIe fabric of the VPX-187 across a VPX backplane. See Figure 2, VPX System using SRIO and PCIe. The VPX6-187 provides two fabric ports which may be configured to operate as SRIO or PCIe and two fabric ports that operate permanently as SRIO. The configuration of the ports is controlled by parameters stored in non-volatile memory. Changes to the port configuration are made via the CSA user interface. A system reboot is required to affect any changes to the port configuration.

Figure 2: VPX System with mixed PCI and SRIO

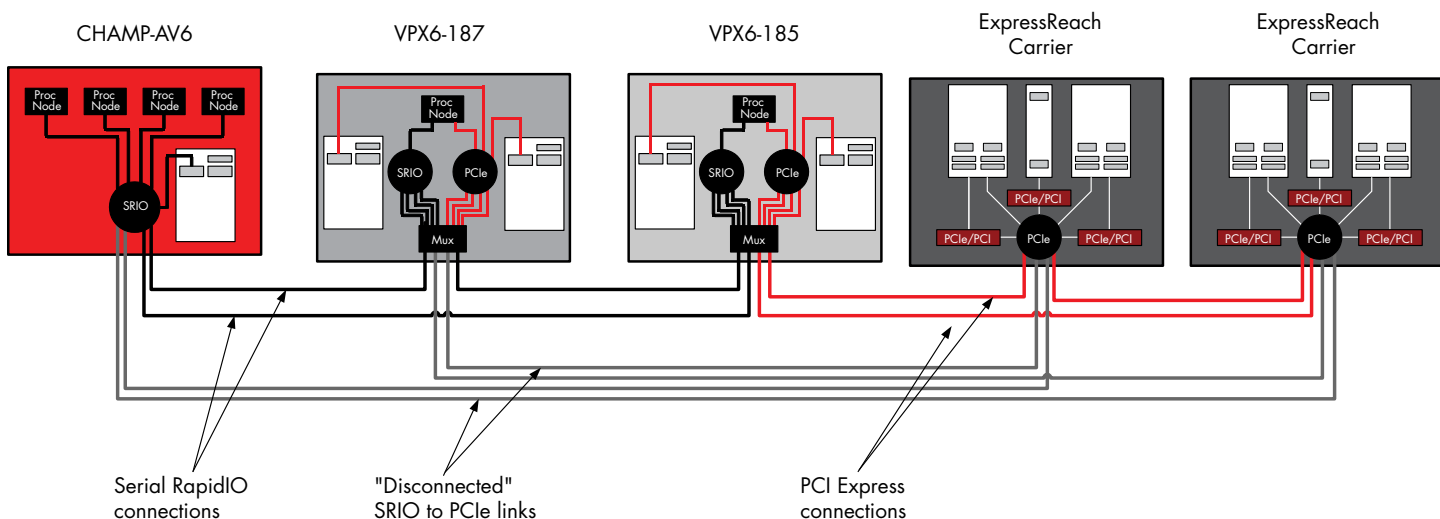



Proposed OpenVPX Profile Support

The VPX6-187 has been designed to be OpenVPX Ready*. Please contact factory for information on proposed slot profiles.

DoubleData Rate (DDR3) SDRAM

The VPX6-187 has two independent DDR3 memory controllers supporting two banks of DDR3 SDRAM. The VPX6-187 may be fitted with 1GB, 2GB or 4GB of DDR3 SDRAM. The DDR3 interface operates at a rate up to 1066MHz resulting in a peak bandwidth of 8.6GB/s per memory bank, 17.2GB/s total.

To preserve data integrity, the SDRAM is provided with Error Checking and Correcting (ECC) circuitry that detects and corrects all single-bit data errors, detects all double-bit errors, and detects all three- and four-bit errors within the same nibble. The SDRAM is accessible from the processor and from the PCIe and SRIO interfaces. Subject to the configuration of BSP settings controlling the memory management of the P4080 processor, the memory can be accessed from other boards via SRIO, local XMC/PMC devices and remote XMC/PMC devices on ExpressReach carrier cards.

NOR Flash Memory

The VPX6-187 is available with 256 or 512MB of Flash Memory. The Flash will retain data for 20 years at +85°C. Note: these figures assume the sector the data is in has less than 1,000 erase cycles. The data retention drops as erase cycle count increases. After 1,000 cycles, data retention is for 10 years. After 100,000 cycles, data corruption will likely be noticeable in one year. Read performance of the Flash array is optimized in order to minimize system boot up time for applications such as avionics mission computers where fast restarts after power interruptions are critical.

For absolute security against inadvertent Flash programming or corruption, a hardware jumper is provided to disable writing to Flash. The CSA firmware of the VPX6-187 provides Flash programming functions with support for downloading Flash images over Ethernet. See the separate CSA firmware data sheet for details. See the Non-volatile Memory Security section for more information on write protection and scrub features.

* This product has been designed in accordance to the draft spec and should fit in selected OVPX backplane profiles, since the draft spec is still not formalized as an ANSI standard, things are subject to change.

NAND Flash

The VPX6-187 comes configured with 8GB of NAND Flash.

Permanent Alternate Boot Site (PABS)

PABS provides a backup boot capability in the event that the firmware in the main Flash becomes corrupted. This can occur because of an error during reprogramming or an incorrect image being loaded. PABS provides users with a convenient mechanism to recover from corruption of the main NOR Flash without removing the card from the system in which it is installed. An on-board jumper and a backplane signal (ALT_BOOT) are provided to cause the card to boot from PABS, thus allowing a user to reinstall the standard firmware load. The PABS feature guarantees that a card will never need to be removed from a system to perform NOR Flash updates.

FRAM

A Ramtron FM22L16 Ferroelectric Random Access Memory (FRAM) provides fast, non-volatile storage of mission state data that must not be lost when power is removed. FRAM reads and writes like standard SRAM and as with all FRAM devices, writes occur at bus speed and are immediately non-volatile. The FRAM memory is non-volatile due to its unique ferroelectric memory process which means that data is retained after power is removed. It provides data retention for over 10 years. Fast write timing and high write endurance make FRAM superior to other types of memory. The FM22L16 includes a low voltage monitor that blocks access to the memory array when VDD drops below a critical threshold. The memory is protected against an inadvertent access and data corruption under this condition. The device also features software-controlled write protection.

Non-volatile Memory Security

The VPX6-187, as well as other Curtiss-Wright Controls Continuum Architecture products, provides for the management of non-volatile memory devices in classified circumstances. All of the non-volatile devices, Flash, PABS Flash, FRAM and FPGA PROM may be individually write-protected by a hardware jumper. The jumpers may be visually inspected to conform to security procedures. To facilitate with the management of sealed-box systems, a backplane signal (NVMRO) may be asserted to over-ride the hardware write protection. The CSA firmware of the VPX6-187 provides non-volatile scrub functions to perform a secure erase per NISPOM requirements.



The VPX6-187 I/O System

The VPX6-187 features a large number of I/O interfaces including EIA-232, EIA-422/485 serial, USB, Ethernet, MIL-STD-1553, SATA, TTL and differential discrete I/O. The details of the I/O interfaces are described in the following sections. The VPX6-187 provides for an I/O expansion facility with the inclusion of the Interface Personality Module (IPM). The IPM concept, carried forward from the VME-182, 183 and 184 SBCs as well as the VPX6-185, is a connectorized subassembly that can either simply provide physical-level transceivers for controller devices implemented in the Core Functions FPGA or it can host PCI peripherals such as a SATA interface device. Some of the optional I/O features are implemented with IPM modules. Refer to Table 2 for a summary of the I/O configurations that are available on the VPX6-187.

Four Gigabit Ethernet Interface, OpenVPX SERDES and Pinout Options

The VPX6-187 is equipped with up to four 10/100/1000 BASE-TX Ethernet interfaces, all implemented within the P4080. Three of the Ethernet ports are routed to the backplane connector P4. One port is factory configured to be present on the front panel connector (air-cooled cards) for standard product variants or to the backplane connector P4 for customer specific variants (note that this shares XMC site 1 differential I/O pairs). The Ethernet controllers integrate a number of features designed to minimize processor loading due to Ethernet traffic. These include dedicated DMA engines, support for jumbo packets up to 9KB, efficient buffer management schemes, checksum calculation for IP, TCP, and UDP, and interrupt coalescence. The VPX6-187 also supports two 1000BaseX (SERDES) Ethernet ports which is available as per OpenVPX Slot profile SLT6-PAY-4F1Q2U2T.

Dual Serial ATA Interface Option

The VPX6-187 optionally provides two SATA 1.0 (1.5Gb/s) interfaces based on the Silicon Image 3124 device. Each interface incorporates several performance-enhancing features such as:

- ◆ Independent DMA channel with 2K FIFO
- ◆ Independent command fetch, scatter/ gather, and command execution

See Table 2 for configurations that include SATA.

Four EIA-232 Serial Ports

All VPX6-187 configurations have a minimum of four EIA-232 serial channels. The EIA-232 serial ports (Channels 1, 2, 7, 8) support asynchronous communications with one transmit and one receive signal. All four ports are connected to both a front panel connector and the backplane connector. One serial port supports the use of the DTR signal to automatically detect the connection of a data terminal and can be used to control the boot-up sequence of the card if desired. The four serial ports are implemented with the P4080's dual DUARTs. The baud rate of all four ports can be set independently from 300 to 115200.

Four EIA-232/422/485 Serial Port Option

The VPX6-187 is available in configurations with one, two or four additional serial ports (channel numbers 3-6). These additional serial ports are implemented with 85230 Serial Communication Controller (SCC) cores in both the Core Functions FPGA and in all of the IPM modules. All of the serial ports support asynchronous communication with baud rates of 300 to 115200. All of the serial ports support synchronous HDLC/SDLC communications at up to 2.0MB/s. In synchronous mode a full range of data encoding schemes are supported. (NRZ, NRZI Mark, NRZI Space, FM0, FM1, Manchester, and Differential Manchester) The synchronous ports support separate transmit and receive clock signals and can use internal or external clocking, or clock encoded schemes. All of the serial ports support software selection of either EIA-232 (async only) or EIA-422/485 (sync or async) signal levels. See the Differential Discrete I/O section below for information on how the VPX6-187 provides the capability to control each of the EIA-422/485 drivers and receivers as differential-mode discrete signals for use as serial control signals or general purpose I/O. See Table 2 for configurations that include the optional 232/422/485 serial channels.

LVTTTL Discrete Digital I/O Option

The VPX6-187 optionally provides 14-bits of LVTTTL compatible discrete digital I/O. Each bit is individually programmable to be an input or output. Each I/O bit is capable of generating an interrupt upon a change of state, programmable to detect either edge. Each bit has a 10K pull-up resistor to 5V. The output drive current is 24 mA. See Table 2 for configurations that include the optional DIO signals.



Differential Discrete Digital I/O

The VPX6-187 provides the capability to control each of the EIA-422/485 drivers and receivers as differential-mode discrete signals via registers in the Core Functions FPGA. This allows flexibility in how the drivers and receivers are used. The choice of whether the drivers and receivers are attached to serial ports or used as discrete differential I/O is software selectable on a per-serial channel basis. When configured as discrete differential I/O, the drivers and receivers can be used as serial-line control signals (RTS, CD, etc.) in conjunction with another serial channel, or used as general-purpose differential mode control signals unrelated to serial I/O requirements. Differential discrete inputs can generate an interrupt upon a change of state, with programmable edge direction. Note that if the serial channel physical levels are set to EIA-232, then discrete digital I/O at EIA-232 levels is obtained.

Two USB 2.0 Ports

The VPX6-187 provide two USB ports integrated into the P4080. Each port can handle high-speed (480MB/s), full-speed (12MB/s), and low-speed (1.5MB/s) operation. When operating at low-speed or full-speed, each port is managed by independent OHCI-compliant controllers internal to the device. One EHCI-compliant controller manages any ports operating in high-speed mode.

One USB port is accessible on the front panel connector and the other is accessible on the P3 or P4 connector (variant dependent). Each port provides a +5V output to power external USB devices such as keyboards.

Two Channel MIL-STD-1553 Option

The VPX6-187 provides up to two MIL-STD-1553 channels implemented with DDC 65864 micro-ACE TE devices offering the following key features:

- ◆ Support for MIL-STD-1553A, MIL-STD-1553B Notice 2, and STANAG 3838 protocols
- ◆ BC, RT, MT modes independently selectable for each channel
- ◆ Choice of transformer-coupled (standard) or direct-coupled outputs (on a special order basis)
- ◆ MIL-STD-1760 amplitude compliant
- ◆ 64K words of RAM per channel, with parity
- ◆ PCI interface is 33MHz, 32-bit and supports burst writes with a FIFO for up to one complete MIL-STD-1553 message

- ◆ Transmit Inhibit input for each channel
- ◆ Bus Controller features:
 - Highly autonomous bus controller with built-in message sequence control engine for multi-frame message scheduling, branching, and asynchronous message insertion
 - Programmable inter-message gap size
 - Single frame or auto-repeat modes
 - Automatic retries
 - Time-tag can be transmitted with Synchronize With Data mode code
 - External Trigger input for each channel
- ◆ Remote Terminal features
 - Programmable illegalization of RT commands
 - Busy bit programmable on a sub-address basis
 - 16-bit time-tag option with options of 2, 4, 8, 16, 32, or 64 μ sec/LSB based on internal clock
 - External time-tag clock input
 - Time-tag can be set via Synchronize With Data mode code
 - External Subsystem Flag input
- ◆ Monitoring Terminal features
 - Selective message monitor mode, use for selecting monitoring based on RT address, Transmit/Receive bit, and Sub-address
 - Simultaneous RT and monitor modes The RT address for each channel can be set by software

A backplane configuration input is provided for each channel that can cause the RT address to be set by subset of the TTL discrete digital I/O lines. To meet the MIL-STD-1760 First Response requirement of an RT response within 150 msec, one of the MIL-STD-1553 channels initializes as an RT with the Busy status word bit set. This requires that the MIL-STD-1553 channel be configured to set the RT address in hardware.

Curtiss-Wright Controls' driver software for the VPX6-187's MIL-STD-1553 channels provides a flexible, easy to use, and robust applications programming interface (API). The driver supports BC, RT, and MT modes of operation, and offers a high degree of compatibility to the proven software driver provided for Curtiss-Wright Controls' popular PMC-601 MIL-STD-1553 module. Source code is provided for user reference. The MIL-STD-1553 driver for the VPX6-187 is sold separately from the hardware and the VPX6-187 BSPs. See separate data sheet for details.



Table 2: Summary of I/O Options

Mode	Front Panel (air-cooled only)	Backplane Connector P1 – P6
#0 (Standard Product)	<ul style="list-style-type: none"> • EIA-232 Serial channels 1,2,7,8 • Serial cable detect • Gigabit Ethernet port 4 • USB port 2 • Card Reset 	<ul style="list-style-type: none"> • EIA-232 Serial channels 1, 2, 7, 8 • Serial cable detect • Gigabit Ethernet ports 1-3 • Optional Ethernet port 4 • USB port 1 • Card Fail output • Alternate boot input • NVMRO input • Reset input • XMC1 Pn6 I/O (20 diff pairs + 38 single-ended) • PMC2 Pn4 I/O (64 pins) • XMC2 Pn6 I/O (12 diff pairs)
#6 (Standard Product)	Same	Same as Mode 0 with additional: <ul style="list-style-type: none"> • EIA-422/485 serial channels 3-6 • 14 DIO
#8 (By customer specific request)	Same	Same as Mode #9 only with MIL-STD-1553 channel 1
#9 (Standard Product)	Same	Same as Mode 0 with additional: <ul style="list-style-type: none"> • MIL-STD-1553 channels 1-2 • EIA-422/485 serial channels 3-4 • 14 DIO
#11 (Standard Product)	Same	Same as Mode 0 with additional: <ul style="list-style-type: none"> • MIL-STD-1553 channel 1 • Serial ATA channels 1-2 • EIA-422/485 serial channels 3-4 • 14 DIO
#12 (Standard Product)	Same	Same as Mode #11 but without MIL-STD-1553

Real-Time Clock (RTC)

A Maxim/Dallas Semiconductor DS3231 RTC chip provides the RTC function. It contains registers for century, year, month, day, hours, minutes, and seconds. The RTC is capable of generating alarm interrupts. The RTC draws its power from 3V3_AUX. In the event of loss of backplane 3V3_AUX power, the RTC will automatically switch over to draw power from the backplane VBAT line (P1-G3).

Multi-board Synchronous Clock

The VPX6-187 includes a special purpose counter which may be synchronized with corresponding counters on other boards in the same system. This common time base allows a developer to time-stamp messages and/or data buffers, with the knowledge that the local time is maintained at the

same value by all the boards in the system. The counter can be set to roll-over to a pre-load value and interrupt on roll-over. This feature is typically most valuable for debugging and instrumenting multi-board applications code, which can present challenges in coordinating the distribution of data items between processors. The MBSC makes use of the VITA 46 reference clock and does not require any special backplane wiring. See the section on Continuum Insights Multiprocessor tools for information on how the MBSC can be used to coordinate timing between multiple boards.

Extensive Timing Resources

The VPX6-187 provides a large number of timing resources to facilitate precise timing and control of system events. The list of available timers is given in Table 3.



Table 3: VPX6-187 Timing Resources

Timer	Implementation	Type	Size	Tick Rate / Period	Maximum Duration
PowerPC Time Base Register	One Per CPU	Free Running Counter	64	125MHz/8nsec	4,676 yrs
PowerPC Decrementer	One Per CPU	Presetable, Readable Downcounter	32-bit	125MHz/8nsec	34.35 sec
General Purpose #0-7	P4080 MPIC	Presetable, Readable Downcounter with auto-read and stop options, divide by 8, 16, 32 and 64	32-bit	divide 16	114 sec
RTC Alarm	Real-time clock	Alarm Interrupt	-	-	-
Watchdog timers (1 per CPU)	Core Functions FPGA	Presetable, readable downcounter with interrupt or reset on terminal count	25-bit	1MHz/1usec	33.55 sec
System Timers #1-6	Core Functions FPGA	Presetable, readable downcounter with interrupt on terminal count	32-bit	50MHz/20nsec	85.9 sec

Avionics Watchdog Timers

The VPX6-187 provides two watchdog timers. Each watchdog timer is a pre-settable down-counter with a resolution of 1 μ sec. Time-out periods from 1 msec to 33 seconds can be programmed. Initialization software can select whether a watchdog exception event causes a software interrupt, a processor reset, a card reset or a system reset. Once enabled to cause a reset, the watchdog cannot be disabled. A watchdog event indicator discrete signal is output to the backplane.

The watchdog timer can be used in two ways. As a standard watchdog timer, a single time period is programmed which defines a maximum interval between writes to the watchdog register. For increased system integrity, the watchdog can optionally be configured to operate in "Avionics" mode whereby a minimum interval between writes to the watchdog register is also enforced. In other words, writing to the watchdog register too soon or too late causes an exception event.

General Purpose DMA Controllers

The P4080 provides two four channel DMA controller that available for general purpose use. The DMA controller can be used for transferring blocks of data between the SDRAM, Flash memory, device bus peripherals, SRIO-mapped memory and the PCI busses. The DMA controllers support direct and descriptor-driven chained operation. The DMA controllers can support source and destination striding. The

DMA controllers also feature a bandwidth management feature to allow the user to control the distribution of bandwidth between the four DMA channels.

XMC/PMC Sites

The VPX6-187 is equipped with two mezzanine sites. One mezzanine is capable of supporting a IEEE 1386 PMC or VITA 42.3 XMC module with 64-bits of Pn4 I/O and 12-pairs of differential Pn6 I/O from that site to the backplane connectors as per VITA 46.9. The second mezzanine is designed to support only an XMC with maximum I/O providing 20 differential pairs and 38 single-end signals routed as per VITA 46.9.

On conduction-cooled cards, the XMC/PMC sites adhere to the VITA 20- 2001 (R2005) conduction-cooled PCI Mezzanine Card (PMC) standard specifications. To optimize the thermal transfer from XMC/PMC modules to the base card the standard VPX6-187 thermal frame incorporates both the Primary and Secondary thermal interfaces as defined by VITA 20-2001.

The VPX6-187 is capable of hosting Processor PMCs in non-Monarch mode as described in the VITA 32-2003 draft standard (the Monarch# signal is pulled to VIO). The VPX6-187 does not support the optional second PCI agent, the optional EREADY signal, or the optional RESETOUT# signal.

Table 4 XMC/PMC site specifications provides details on the capabilities of both mezzanine sites.



Table 4: VPX6-187 PMC/XMC Specifications

Function	Site 1	Site 2
Location	Top of card	Bottom of card
PCI interface	-	PCI-X 64-bit 133MHz via 4-lane PCIe/PCI bridge
PCIe interface	8-lane per VITA 42.3 2GB/s peak simultaneous transmit and receive	Up to 8-lane per VITA 42.3 2GB/s peak simultaneous transmit and receive
Pn4 I/O	-	64-bits to VITA 46 P5 per VITA 46.9 rule 5-5, pattern P64 (P5-64S)
Pn6 I/O	20 different pairs and 38 single-ended to VITA 46 P3 and P4 as per VITA 46.9 X8D+12D+38S (See Note 1)	12 differential pairs to VITA 46 P6 per VITA 46.9 rule 5-5, pattern x12D (P6-x12d)
Differential routing	100 Ohm differential, 50 Ohm nominal for Pn3, Pn4 and Pn6 I/O signals	
VIO	-	Jumper select for 3.3V or 5V
3.3V power	Provided from on-board PSU, 13W maximum to any one site. 20W total maximum. The 3.3V is sequenced with the main board power.	
5.0V power	Drawn from backplane 5.0V (VS3) 20W maximum to any one site, 30W maximum total. The 5V is sequenced with the main board power.	

Note
 1. The VPX6-187 has an option to route the 4th Gigabit Ethernet to the backplane. In this configuration the Gigabit Ethernet signals replace the upper four XMC differential pairs of site 1.

Status Indicators and Controls

The VPX6-187 SBC provides run/fail status by asserting a backplane signal and illuminating a red front panel LED in the event the diagnostics detect a card failure. There are also a software controlled green LED that the application can use to indicate status of CPU cores. A card reset signal is available on the backplane connectors and on the front panel connector on air-cooled cards. The front panel cable for the VPX6-187 includes a push button switch that interfaces to this signal to allow the card to be reset without doing a full system reset.

Debug Interfaces

For debugging purposes, the VPX6-187 provides an optional test IPM and cables. There are two debug interfaces provided. The first is traditional JTAG COPs interface where the developer can connect the card to an in-circuit emulator via a standard 2x11 connector. The second interface is to the high-speed Aurora debug port on the P4080. This connection is made through a high-speed standard SAMTEC ASP-137969-01 connector.

Consult Curtiss-Wright Controls for more information if you need to use a COP emulator with the VPX6-187.

Temperature Sensors

The VPX6-187 provides temperature sensors to measure board and processor temperatures. The temperature sensors are located at each edge of the card, one sensor close to the P4080 and one on the processor. The sensors are accessed through the IPMI interface, such that they can be queried by either the processor or IPMI controller.

Software Support

Continuum Software Architecture (CSA)

The VPX6-187 is supported by a suite of firmware, RTOS BSPs, communication libraries and signal processing libraries. The Continuum Software Architecture is Curtiss-Wright Controls' suite of firmware and BSP APIs that is common to SBCs (VME, cPCI and VPX) and multi-processor boards. Developers of mixed systems will find a common set of features and software interfaces for all future processing products from Curtiss-Wright Controls. The Continuum Software Architecture is comprised of:

Continuum Firmware Monitor

The monitor provides a command line interface over serial port or Ethernet to allow a user to perform a variety of system integration activities with the card. The monitor provides debug and display commands, diagnostic results display and exerciser controls, non-volatile memory programming and declassification and programming of parameters used to control boot-up and diagnostics.



Continuum Built-in-Test (BIT)

BIT is a library of diagnostic routines to support Power-up BIT (PBIT), Initiated BIT (IBIT), and Continuous BIT (CBIT) designed to provide 95% fault coverage.

Operating System Software

The VPX6-187 is supported with an extensive array of software items, which cover all facets of developing application code for the board. Users have the option of choosing to develop with a variety of operating systems and development tools. The following operating systems are supported or planned for the VPX6-187.

- ♦ VxWorks 6.x, Workbench 2.x from Wind River
Part number DSW-187-0006-CD
- ♦ Curtiss-Wright Controls developed Wind River Linux is available (3.x) - part number: DSW-187-6100-GPP

Continuum Inter-Processor Communications (IPC) Library

The IPC Library is a library of functions designed to enable high-performance, low-latency message passing. IPC allows processors to communicate task-to-task, on the same card over local interconnect or between boards over a system level interconnect. IPC supports several transport mechanisms including PCI/PCIe, StarFabric and SRIO. Applications developed on CHAMP-AV2/3/4/6 or SVME/DMV-183/184 and VPX6-185 will port to the VPX6-187 with no changes related to the IPC layer.

Continuum IPC provides low-overhead block data transfers, segmented block data transfers and signaling between processors to assist in high-bandwidth data movement. See the Continuum IPC Library data sheet for more details.

Continuum Insights Multiprocessor Development Tools

Complex systems with many processing nodes and networked interconnect architecture require specialized tools to debug and verify their operation. The Continuum Insights tools facilitate the development of such systems by providing a graphical representation of the configuration, real-time performance and network traffic of systems under development. Based on the Eclipse IDE and Wind River Systems' Workbench platform development tools, the Insights tools provide:

- ♦ Instrumentation and analysis tools to collect real-time system event data. A post run-time analysis tool allows developers to debug and verify critical interaction among multiple processors. Event data can be collected from processing nodes in the system synchronized to a common precision time-base.
- ♦ Run-time system monitoring with graphical display of threads, processor utilization, task allocations and fabric performance of individual nodes or clusters of nodes. The monitoring tool encourages real-time user interaction to control processes or data transfers by displaying results in a "dashboard-like" display format.
- ♦ Network analysis tool to view the system physical topology, measure network bandwidth loads, manage and optimize packet routing with awareness of IPC-defined end-points so developers can easily correlate traffic to the system software.



Cables and Rear Transition Modules

The VPX6-187 features a high-density front panel connector on air-cooled versions of the board and makes use of existing cables. A cable is available, part number CBL-185-FPL-000 that breaks out the signals to a number of standard connectors. The cable provides four 9-pin DE-9 connectors for EIA-232 channels, one RJ-45 connector for Gigabit Ethernet, one USB connector and a card reset push-button.

To gain access to the backplane I/O signals of the VPX6-187, a Rear Transition Module (RTM) will be available, part number RTM6-185-000 or RTM-187-000. The RTM6 is a 6Ux80mm (1101.10 compliant) module with a rear face plate and injector/ejector handles that plugs into the rear of the VPX backplane to make connections with the I/O signals emanating from the VPX6-187. The RTMs features a 100-pin

high density connector that in conjunction with a breakout cable provides access to all of the base-card I/O and IPM module I/O. Different breakout cables are available for each basecard/IPM combination. The RTM provides additional high-speed connectors to provide access to PMC/XMC I/O.

Figure 3: RTM6-185 and cable set

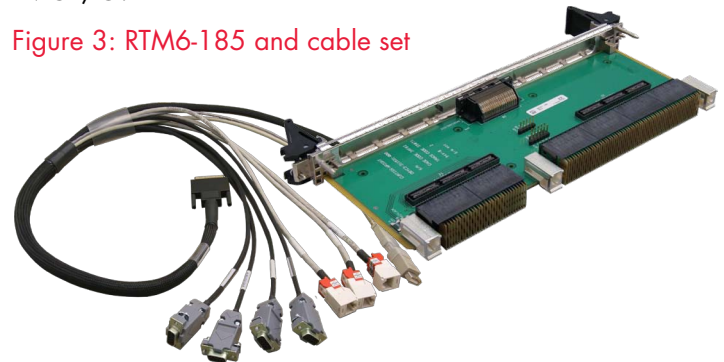

Table 5: VPX6-187 Cables and RTM

Cable Number	Connects To	Description
CBL-185-FPL-000	VPX6-185 Front Panel Cable	Front panel break-out cable for VPX6-185 and 187 providing four 9-pin D connectors for RS-232 ports, 1x RJ-45 jack for GbE, 1x USB Type A receptacle, and 1x push-button reset switch.
CBL-185-IPM-006	VPX6-185 RTM IPM Mode 6 Cable	Breakout cable for VPX6-185 and 187 in pin-out mode 6. Provides separate branches for 2x 9-pin D connectors for RS-232 ports and 4x 25-pin D connectors for RS-422/485 ports. This cable connects to the high-density connector for IPM-specific I/O on RTM6-185-000.
CBL-185-IPM-009	VPX6-185 RTM IPM Mode 9 Cable	Break-out cable for VPX6-185 and 187 in mode 8 (single MIL-STD-1553) and mode 9 (dual MIL-STD-1553) versions. Provides separate branches and connectors for the transformer-coupled MIL-STD-1553 signals, MIL-STD-1553 configuration inputs, 2x RS-232/422/485 ports, and 25-pin female D connector for TTL discretes. Connectors for MIL-STD-1553 signals are 3-lug Twinax bulkhead jack connectors (Trompeter part number BJ79-47). This cable connects to the high-density connector for IPM-specific I/O on RTM6-185-000.
CBL-185-IPM-011	VPX6-185 RTM IPM Mode 11 Cable	Break-out cable for VPX6-185 and 187 in mode 11.
CBL-185-IPM-012	VPX6-185 RTM IPM Mode 12 Cable	Break-out cable for VPX6-185 and 187 in mode 12.
CBL-185-RPL-000	VPX6-185 Rear Panel Cable (RTM)	Break-out cable for VPX6-185 RTM providing 4x RS232 ports on DE-9 connectors, 3x GbE ports on RJ45 jacks, 1x USB on USB plug, 1x push button reset switch and 1x DB25 pin contacts (male) offering DIO, CARDFAIL and ALT_BOOT.
CBL-187-RPL-000	VPX6-187 Rear Panel Cable (RTM) (in 1000Bx mode)	Break-out cable for VPX6-187 RTM providing 4x RS232 ports on DE-9 connectors, 1x GbE ports on RJ45 jacks, 1x USB on USB plug, 1x push button reset switch and 1x DB25 pin contacts (male) offering DIO, CARDFAIL and ALT_BOOT.
RTM6-185-000	RTM for the VPX6-185 and 187	RTM for the VPX6-185 - contains 2 PMC/XMC I/O interface connectors and a dual ultra SCSI connector for basecard and IPM I/O. Access is provided to VPX6-185 IPM I/O, board I/O (serial ports, Ethernet, USB), and XMC and PMC sites.
RTM6-187-000	RTM for the VPX6-187	RTM for the VPX6-187 - contains 2 PMC/XMC I/O interface connectors and a dual ultra SCSI connector for basecard and IPM I/O. Access is provided to VPX6-187 IPM I/O, board I/O (serial ports, Ethernet, USB), and XMC and PMC sites.
RIM-185-000	PMC RTM Interface Module (RIM)	PMC RTM RIM for the RTM6-185. This RIM provides a generic connection to the VPX6-185 PMC sites of the VPX6-185 RTM. 64-pins of PMC I/O is provided on a front panel 78-pin DSUB connector for easy access. QTY 2 PMC RIM modules are provided.



Power Consumption

See Table 6 for power consumption figures for the VPX6-187 standard product variant base-cards. Power consumption increases as operating temperature rises. Table 6 figures are for the highest rated operating temperature while executing a test application generating CPU processing loads and data traffic representative of a typical customer application.

The VPX6-185 is designed to run off 5V or 12V, and does not draw current from the other voltage rails for normal operation. It does draw current of 3.3V_AUX, which is less than 500mA. Hence, power consumption in the table below is for 5V or 12V only. The PMC site always draws power from the 5V rail. The XMC site is provided with VPWR (either +5V Or +12V) variant dependent.

See Table 7 for power consumption figures for the Interface Personality Modules available with the VPX6-187.

Table 6: Variant Power Requirements

Ruggedization Level	Part Number	Reference Configuration	Typical Power (W)
Level 0 Air-cooled	VPX6-187-A01B200	P4080 @ 1.5GHz 2GB DDR3 8GB NAND AC0	TBD
	VPX6-187-A01C200	P4080 @ 1.5GHz 2GB DDR3 8GB NAND 1000BX AC0	TBD
Level 100 Air-cooled	VPX6-187-A11B200	P4080 @ 1.5GHz 2GB DDR3 8GB NAND AC100	TBD
	VPX6-187-A11C200	P4080 @ 1.5GHz 2GB DDR3 8GB NAND 1000BX AC100	TBD
Level 200 Conduction-cooled	VPX6-187-C21B200	P4080 @ 1.5GHz 2GB DDR3 8GB NAND C200	TBD
	VPX6-187-C21C200	P4080 @ 1.5GHz 2GB DDR3 8GB NAND 1000BX C200	TBD

Notes:

1. Typical power is measured power while running stress test software that exercises CPU and board functions including AltiVec. The actual power consumption observed will vary by application.
2. For thermal design considerations, Curtiss-Wright Controls recommends adding 5% to the typical power consumption figures. For power supply sizing, Curtiss-Wright Controls recommends adding 20% to the typical power consumption figures.

Table 7: IPM Power Requirements

Ruggedization Level		Typical Power (Watts) (see note)
All	Mode 6 IPM	2
All	Mode 9 IPM with both MIL-STD-1553 channels at 50% Tx time	5
All	Mode 9 IPM with both MIL-STD-1553 channels at 25% Tx time	3
All	Mode 11 IPM with MIL-STD-1553 channels at 50% Tx time	4
All	Mode 11 IPM with MIL-STD-1553 channels at 25% Tx time	3
All	Mode 12 IPM	2

Notes:

1. For thermal design considerations, Curtiss-Wright Controls recommends adding 5% to the typical power consumption figures. For power supply sizing, Curtiss-Wright Controls recommends adding 20% to the typical power consumption figures.



Specifications

The tables below show the power, dimensions and weight characteristics of the card.

Table 8: VPX6-187 Dimensions and Weight

Dimensions and Weight		
Option	Dimensions	Weight (grams)
Air-cooled 0.8"	per VITA 46 draft 0.8" pitch	~600 (target)
Air-cooled 1.0" option	per VITA 46 draft 1.0" pitch	~650 (target)
Conduction-cooled	per VITA 46 draft 0.8" pitch	~775 (target)
Conduction-cooled LRM	per VITA 46 draft 0.85" pitch	~900 (target)

Notes: The air-cooled format is designed to fit chassis with 0.8" slot pitch. For convenience it is offered with a 1" front panel to accommodate installation in 1" pitch chassis.

Air-cooled cards available in temperature ranges 0 and 1.*

Conduction-cooled cards available in temperature ranges 1 and 2.

Conduction cooled cards available in a covered, 2-level maintenance LRM configuration.

* Refer to Ruggedization Guidelines data sheet for more information.

Table 9: VPX6-187 Cooling Requirements

Cooling Air Requirements		
Configuration	Temperature Range	Air-Flow
Dual-core up to 1.5GHz	-40°C to 71°C	~15 CFM (target)

Air-flow is specified for sea-level conditions. The temperature refers to the inlet temperature at the card. The air-flow specifications are for worst case (highest power) conditions, without any PMC/XMCs installed. Curtiss-Wright Controls can supply additional recommendations for specific power/temperature/altitude scenarios and pressure drop characteristics of the VPX6-187 support the design and testing of cooling subsystems.

Ruggedization Levels

Air-cooled cards are available in levels 0, 100.

Conduction-cooled cards are available in levels 100 and 200 and a 2-level maintenance (LRM) configuration with ESD protective covers. See the Curtiss-Wright Controls ruggedization guidelines factsheet for more information.



Ordering Information

The VPX6-187 is ordered with the following part numbers. VPX6-187-UVWXYZ, where U, V, W, X, Y and Z denote cooling method, temperature range, mechanical format and functional configuration respectively. Not all possible configurations are offered, consult Curtiss-Wright Controls for available configurations.

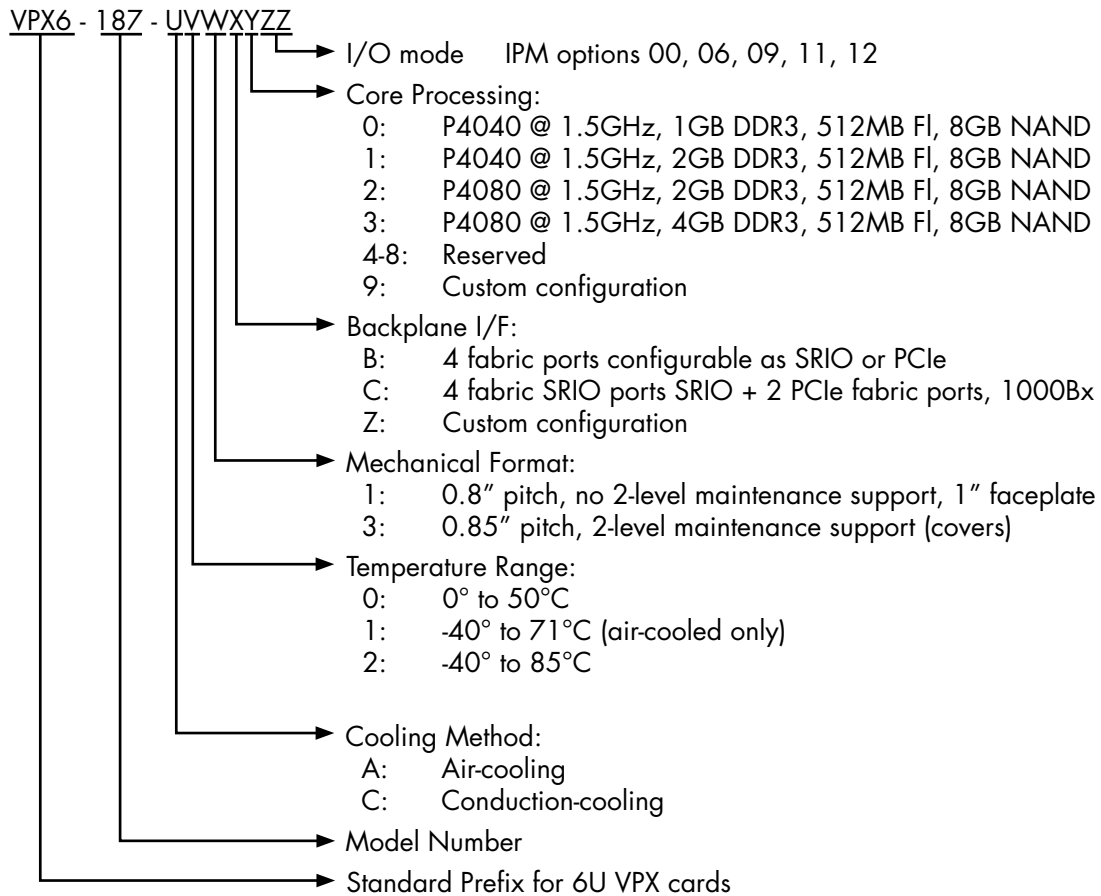



Warranty

This product has a one year warranty.

Contact Information

To find your appropriate sales representative, please visit:

Website: www.cwcmbedded.com/sales

Email: sales@cwcmbedded.com

For technical support, please visit:

Website: www.cwcmbedded.com/support1

Email: support1@cwcmbedded.com

The information in this document is subject to change without notice and should not be construed as a commitment by Curtiss-Wright Controls Embedded Computing. While reasonable precautions have been taken, Curtiss-Wright Controls assumes no responsibility for any errors that may appear in this document. All products shown or mentioned are trademarks or registered trademarks of their respective owners.