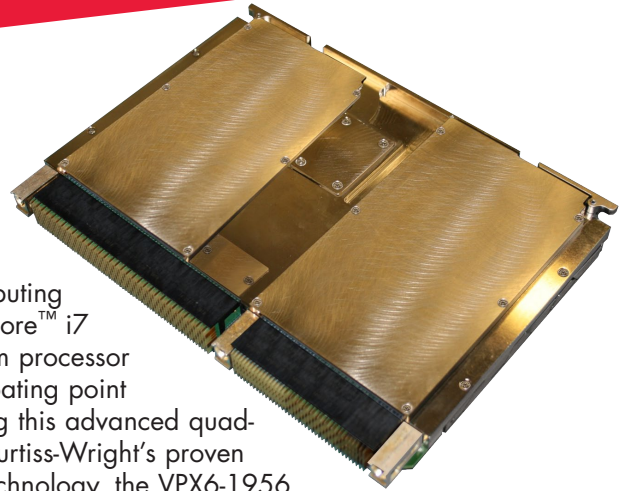

Photo courtesy of  
General Dynamics  
Land Systems Inc.

Fact Sheet

# VPX6-1956

## VPX™ Intel® Core™ i7 Quad-Core Single Board Computer



- ◆ 6U VPX™ form factor
- ◆ Intel® Core™ i7 Quad-Core 32nm processor
  - 2.1 GHz
  - Quad-Core CPU
  - 6 MB L3 cache
  - Intel AVX Floating Point
- ◆ Up to 16 GB DDR3 SDRAM
- ◆ 16-32 GB NAND flash drive
- ◆ Trusted COTS ready
- ◆ Intel VT-d & TxT support
- ◆ Two XMC/PMC sites
- ◆ Intel Graphics: (3) DVI
- ◆ Additional I/O:
  - (2) Gigabit Ethernet
  - (1) AC97 Audio port
  - (2) RS-232
  - (2) RS-422
  - (8) GPIO
  - (5) USB
  - (4) SATA
- ◆ Backplane fabric:
  - (4) 4x SRIO
  - (1) 16x PCIe2 or
  - (2) 8x PCIe2
- ◆ Ruggedized air-cooled and conduction-cooled
- ◆ Windows® XPe/7, Linux®, VxWorks™

The VPX6-1956 from Curtiss-Wright Controls Embedded Computing supports Intel® Core™ i7 Quad-Core 32nm processor with Intel AVX floating point libraries. Utilizing this advanced quad-core CPU and Curtiss-Wright's proven ruggedization technology, the VPX6-1956 is designed for high performance operation in harsh environments. With a 21 GB/s (peak) DDR3 memory subsystem connected directly to the processor, the Intel Quad-Core 32nm device is able to maximize the throughput of the Intel AVX floating point units. This Intel Quad-Core 32nm processor is also equipped with more cache than any previous CPU, allowing it to process larger vectors at peak rates than previous processor technologies. Supplying up to 16 GB of SDRAM and up to 32 GB of flash, the VPX6-1956 is ideal for handling applications with demanding storage, data logging and sensor processing needs.

The VPX6-1956 features high-bandwidth fabrics including Serial RapidIO® (SRIO) and Gen2 PCI Express® (PCIe) to the P1 & P2 connectors. This provides contemporary connectivity between the VPX6-1956 and additional boards in a high performance computing environment. The VPX6-1956 is supported with an extensive suite of industry-preferred software such as VxWorks™, Linux®, and Windows® XPe/7.



Learn More

Sales Info: [sales.cwembedded.com](mailto:sales.cwembedded.com)

Sales Email: [sales@cwembedded.com](mailto:sales@cwembedded.com)

ABOVE & BEYOND



**CURTISS  
WRIGHT** Controls  
Embedded Computing

[cwembedded.com](http://cwembedded.com)



Photo courtesy of  
General Dynamics  
Land Systems Inc.

Fact Sheet

# VPX6-1956

## Features

- ◆ Intel Quad-Core 32nm processor
- ◆ 6 MB L3 Advanced Transfer Cache
- ◆ Up to 16 GB DDR3 SDRAM with ECC
- ◆ Single-slot, 6U board with (2) XMC/PMC sites
- ◆ Intel Trusted Execution Technology (TxT)
- ◆ Intel Virtualization Technology (VT-d)
- ◆ Trusted COTS ready

## I/O Interfaces

- ◆ (2) Gigabit Ethernet
- ◆ AC97 Stereo Audio port
- ◆ (2) RS-232
- ◆ (2) RS-422
- ◆ (8) GPIO
- ◆ (5) USB
- ◆ (4) SATA
- ◆ (1) 16x PCIe2 or (2) 8x PCIe2
- ◆ (4) 4x SRIO

Figure 1: VPX6-1956 Block Diagram

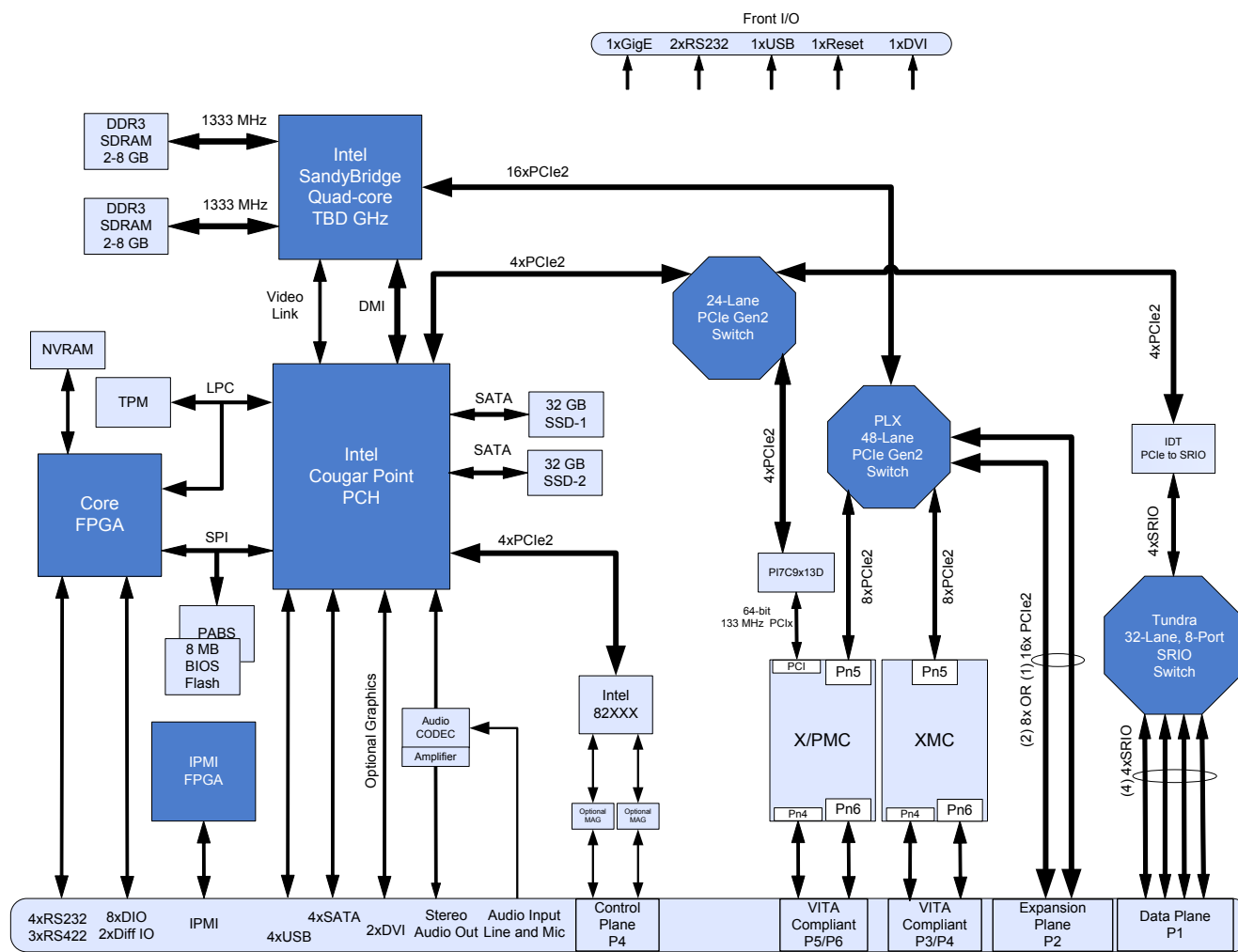

© Copyright 2011, Curtiss-Wright Controls  
All Rights Reserved. MKTFS-EC-VPX6-1956-030411v4-PRELIM

**UNITRONIX Pty Ltd**  
 PO Box 486, Morisset NSW 2264  
 NSW: Tel: 61 2 4977 3511 Fax: 61 2 4977 3522  
 WA: Tel: 61 8 9455 2424 Fax: 61 8 9455 2458  
 unitsyd@unitronix.com.au www.unitronix.com.au