

## 2<sup>nd</sup> Generation Intel® Core™ Processor Single Board Computer



### APPLICATIONS

The TR 80x/39x is a PC-compatible high performance 3U VPX processor board supporting the 2<sup>nd</sup> generation Intel® Core™ processor and the Intel® Series 6 mobile class chipset with up to 8 Gbytes of DDR3-1333 ECC SDRAM. The TR 80x/39x features an XMC site and a range of I/O interfaces including two SATA600 channels, dual 1000Base-BX, RS232/422/485 and USB interfaces. The board provides a flexible PCI Express® (PCIe) backplane fabric interface that can be configured in several ways from eight x1 PCIe ports to a single x8 PCIe port making it

suitable for use in both distributed systems and centralized switching systems as defined in OpenVPX (VITA 65). For rugged applications two VPX-REDI conduction-cooled versions are available, the TR 80x/39x-RCS is a VPX-REDI Type 1 Two-Level Maintenance conduction-cooled board and the TR 80x/39x-RCT is VPX-REDI Type 2. The board is suitable for a range of applications within industrial control, transport, aerospace, security and defense applications. To simplify integration many standard operating systems are supported.

### HIGHLIGHTS

- 3U VPX (VITA 46.0) N-Series single board computer:
  - air-cooled
  - 0°C to +55°C operating temperature
  - use in commercial (non-rugged) applications
  - 3U VPX 0.8 inch slot
  - optional rear transition module available
- I/O interfaces compatible with several OpenVPX profiles
- 2<sup>nd</sup> generation Intel® Core™ processor:
  - 4-core 2.1 GHz Intel Core i7-2715QE processor
  - 2-core 1.5 GHz Intel Core i7-2610UE processor
  - 2-core 2.2 GHz Intel Core i7-2655LE processor
  - 2-core 2.5 GHz Intel Core i5-2515E processor
- Up to 8 Gbytes DDR3-1333 SDRAM with ECC
- Configurable PCI Express® (PCIe) fabric interface supports:
  - 8 x1 PCIe ports, 2 x4 PCIe ports, 1 x4 + 4 x1 PCIe ports or a 1 x8 PCIe port
  - compatible with OpenVPX module profiles
  - supports up to six non-transparent links
- Optional XMC module interface with rear I/O:
  - XMC module interface (x8 PCI Express® Gen 2)
  - XMC rear I/O P2w1-X24s+X8d+X12d
- 2 x SerDes (1000Base-BX) ports or 1 x SerDes plus 1 x Gigabit Ethernet ports or 2 x Gigabit Ethernet ports
- 2 x SATA600 mass storage interfaces
- Up to 2 x serial interfaces and up to 3 x USB 2.0 interfaces
- Analog graphics interface via rear, optional DisplayPort interface via front panel
- Watchdog and long duration timers
- Optional Built-In Test (BIT) supports:
  - Power-on BIT, Initiated BIT, Continuous BIT
- Front panel I/O:
  - 1 x USB 2.0, 1 x RS232, 1 x 10/100/1000 Mbps Ethernet and 1 x DisplayPort
- Compatible with the FR 331/306 VPX Switch
- Ruggedized conduction-cooled versions (RCx-Series):
  - conduction-cooled to VITA 48.2
  - -40°C to +85°C operating temperature (at card edge)
  - conformally coated
- Support for Linux®, Windows® 7, Windows® Embedded Standard 7, Windows® XP, Windows® XP Embedded, QNX® and VxWorks®

## VPX Single Board Computer

- 3U VPX SBC (N-Series) utilizing the 2<sup>nd</sup> generation Intel® Core™ processor:-
  - air-cooled
  - optional rear panel transition module
- compatible with several OpenVPX module profiles
- for ruggedized VPX-REDI (RCx-Series) version:-
  - conduction-cooled to VITA 48.2
  - -40°C to +85°C at card edge
  - conformally coated
  - see TR 80x/39x-RCx datasheet

## Central Processor

- 4-core 2.1 GHz Intel® Core™ i7-2715QE processor
- 2-core 1.5 GHz Intel® Core™ i7-2610UE processor, 2.2 GHz Intel® Core™ i7-2655LE processor or 2.5 GHz Intel® Core™ i5-2515E processor
- common processor features are:-
  - 32nm process technology
  - 1333 MHz Front Side Bus
  - Intel 64 technology (64-bit computing)
- shared Last-Level on-die cache:
  - 2.1 GHz Intel Core i7-2715QE - 6 Mbytes
  - 1.5 GHz Intel Core i7-2610UE - 4 Mbytes
  - 2.2 GHz Intel Core i7-2655LE - 4 Mbytes
  - 2.5 GHz Intel Core i5-2515E - 3 Mbytes
- utilizes Intel® Series 6 mobile class chipset with Intel® QM67 Platform Controller Hub (PCH)

## SDRAM

- supports up to 8 Gbytes DDR3-1333 ECC SDRAM:-
  - up to 8 Gbytes soldered
  - peak bandwidth of 20 Gbytes/s
  - dual channel architecture
- accessible from processor or VPX fabric

## XMC Interface

- 1 x XMC site, in a single VPX slot (VITA 42.0):-
  - XMC (Switched Mezzanine Card) interface supported by x8 PCI Express® Gen 2 (VITA 42.3)
  - rear I/O P2w1-X24s+X8d+X12d (VITA 46.9)
  - +5V powered
  - XMC version only supports the 2-core processor
- full XMC site is available as a factory build option

## Mass Storage Interfaces

- 2 x SATA600 interface via P1 connector:-
  - transfer rate up to 600 Mbytes/s
- optional on-board SATA300 NAND Flash Disk Module

## Ethernet Interfaces

- factory build option for 2 x 1000 Mbps IEEE802.3z SerDes (1000Base-BX) ports via P1:-
  - with software switchable option for 1 x 10/100/1000 Mbps Ethernet port (with magnetics) plus 1 x SerDes port
- alternative factory build options for 2 x 10/100/1000 Mbps Ethernet ports:-
  - one port with and one port without magnetics or
  - both ports with magnetics
- implemented by Intel® 82580DB Ethernet controller
- optional 10/100/1000 Mbps Ethernet:-
  - implemented using the Ethernet controller within the PCH and via an Intel® 82579 PHY
  - via RJ45 connector on front panel

## Graphics Interface

- implemented by PCH
- analog VGA accessed via P2 rear I/O:-
  - resolutions up to 2048 x 1536 @ 75 Hz
- optional DisplayPort connection on front panel
  - resolutions up to 2560 x 1600 @ 60 Hz
- support for Microsoft® DirectX 10
- support for OpenGL 2.0 under Windows® and Linux

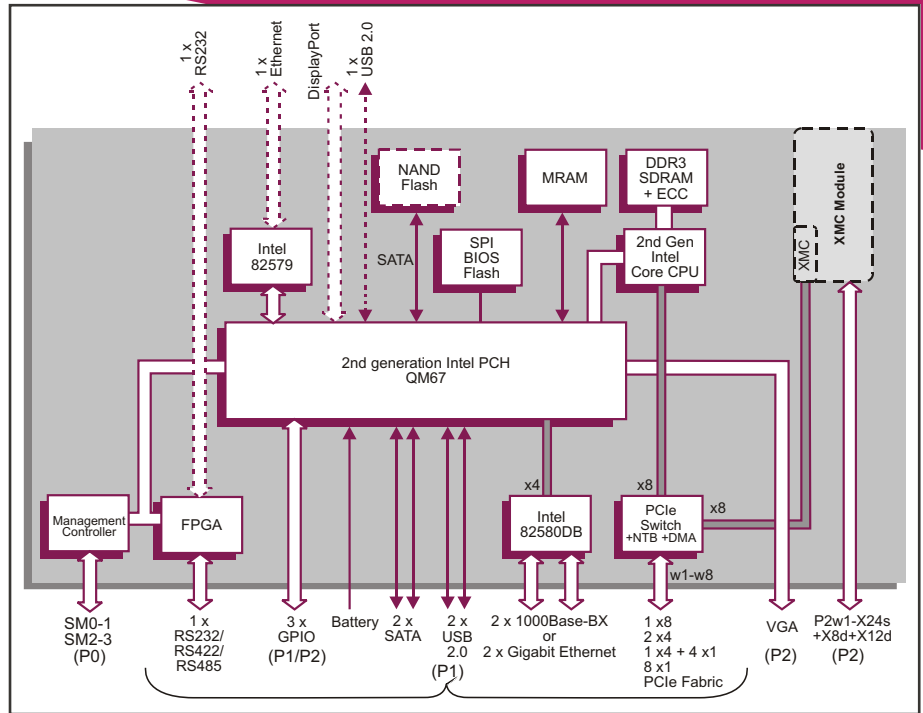

## Serial Interfaces

- 1 x RS232/422/485 channel accessed via P1:-
  - supporting Tx/Rx CTS/RTS in RS-232 only
  - supporting Transmit Control in RS-485 mode
- optional 1 x RS232 channel accessed via front panel, full modem support
- 16550 compatible UARTs

## VPX Backplane Interface

- P0, P1 and P2 support OpenVPX configuration
- configurable PCI Express® (PCIe) fabric interface supports:-
  - 8 x1 PCIe ports, 2 x4 PCIe ports, 1 x4 + 4 x1 PCIe ports, or a 1 x8 PCIe port
  - compatible with OpenVPX module profiles
  - PCI Express Gen 1 and Gen 2 from CPU
- supports up to six non-transparent links for multi-processing configurations
- 2 channel DMA engine for fast data block moves

## Other Peripheral Interfaces

- PC Real Time Clock
- long duration timer; watchdog timer
- CPU temperature monitor; voltages monitor; accessed via System Management interface
- 2 x USB 2.0 interfaces accessed via P1
- optional 1 x USB 2.0 interface via front panel
- 3 x GPIO signals via P1 and P2

## Software Support

- support for Linux®, Windows® 7, Windows® Embedded Standard 7, Windows® XP, Windows® XP Embedded, Windows® Server 2008, QNX® and VxWorks®

## Optional Built-In Test (BIT) Support

- Power-on BIT (PBIT)
- Initiated BIT (IBIT)
- Continuous BIT (CBIT)

## Firmware Support

- Insyde Software InsydeH20™ BIOS
- comprehensive Power-On Self-Test (POST)
- LAN boot firmware included

## Optional VPX Switch

- SBC compatible with FR 331/306 VPX Switch

## Safety

- PCB (PWB) manufactured with flammability rating of 94V-0

## System Management

- System Management interface:-
  - implements SM0-1 and SM2-3 hardware
- on-board System Management Controller
- supports 8 Kbytes of non-volatile memory

## Non-Volatile Memory

- 8 Mbytes of BIOS SPI Flash EPROM
- 128Kbytes MagnetoResistive RAM (MRAM)

## Electrical Specification (Estimated)

- typical current figures (Intel Core i5-2515E processor with 4 Gbytes SDRAM)
  - +5V@ 8A, voltage +5% / -2.5%
  - +3.3V@ 3A, voltage +5% / -2%
  - +12V AUX and -12V AUX routed to XMC site

## Environmental Specification

- operating temperature:-
  - VITA 47 Class AC1, 0°C to +55°C
  - air-cooled
- storage temperature:-
  - VITA 47 Class C1, -40°C to +85°C
- operating altitude:-
  - 0 to 15,000 feet (0 to 4,572 meters)
- relative humidity (operating/storage):-
  - 5% to 95%, non condensing

## Mechanical Specification

- 3U VPX form-factor (VITA 46.0, VITA 48.0)
- 3.9 inches x 6.3 inches (100mm x 160mm)
- slot width (VITA 46.0):-
  - 0.8 inches
- connectors to VITA 46.0 for P0, P1 and P2
- operating mechanical:-
  - shock - VITA 47 Class OS1, 20g
  - random vibration - 0.002g<sup>2</sup>/Hz

## ORDERING INFORMATION

Order Number	Product Description (Hardware)
TR 805/392-yz	4-core Core i7 processor, N-Series
TR 803/39x-yz	2-core Core i7 or Core i5 processor, N-Series

For the order number suffix (yz) options please contact your local sales office:  
 where y = Ethernet I/O where z = SDRAM size; front I/O type  
 y - rear Ethernet configuration z - up to 8 Gbytes SDRAM; front I/O

For accessories please contact your local sales office.

For further information on the VPX (N-Series) and VPX-REDI (RCx-Series) boards please contact your local sales office.

All companies and product names are trademarks of their respective organizations. Specification subject to change; E and OE. RoHS 2002/95/EC compliant.