

2nd Generation Intel® Core™ Processor Dual PMC/XMC VITA 41.4 Controller

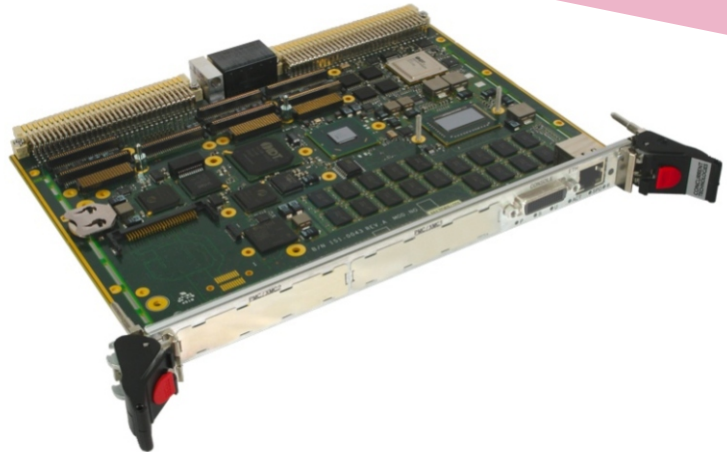

APPLICATIONS

The VX 81x/09x is a PC-compatible high performance VME/VXS processor board supporting the 2nd generation Intel® Core™ processor and the Intel® Series 6 mobile class chipset all with up to 16 Gbytes of DDR3-1333 ECC SDRAM. This single slot board features two PMC/XMC sites, and a variety of interfaces including an optional on-board mass storage. The board supports VITA 41.4 dual x4 PCI Express® backplane fabric interfaces and VITA 41.6 Gigabit IEEE 802.3

(1000 Base-BX) ports. The VX 81x/09x is suitable for a range of applications within the defense, industrial control, telecomms, telemetry, scientific and aerospace markets. For harsher environments, extended temperature, ruggedized air-cooled and ruggedized conduction-cooled versions are supported. To simplify integration, many industry standard operating systems are supported.

HIGHLIGHTS

- 2nd generation Intel® Core™ processor:
 - 4-core 2.1 GHz Intel Core i7-2715QE processor
 - 2-core 1.5 GHz Intel Core i7-2610UE processor
 - 2-core 2.2 GHz Intel Core i7-2655LE processor
 - 2-core 2.5 GHz Intel Core i5-2515E processor
- Up to 16 Gbytes DDR3-1333 SDRAM with ECC
- 2 x SATA interfaces via P0 rear I/O and 2 x SATA interfaces via P2 rear I/O, plus optional on-board drive
- CompactFlash® site on-board
- 2 x PMC/XMC module interfaces:
 - 32/64-bit, 33/66/100 MHz PCI/PCI-X™
 - 2 x XMC module interfaces (x8 PCI Express®)
 - one site supporting Pn4 rear I/O (VITA 35)
- Dual independent displays via front panel and P2 rear I/O
- 2 x serial channels and 6 x USB 2.0 interfaces
- 2 x 10/100/1000Mbps Ethernet channels
- 8 Mbyte BIOS SPI Flash EPROM
- VME64/VME320 interface supporting A64/A32/A24/A16/D64/D32/D16/D8(E0), MBLT64, 2eSST and 2eVME
- Optional VXS P0 connector supporting fabric interfaces:
 - dual x4 PCI Express links (data plane, VITA 41.4) or option for x8 fabric lanes from Pn6 switched via P0
 - dual 1000 Base-BX ports, control plane (VITA 41.6)
- Optional Built-In Test (BIT) support:
 - Power-on BIT, Initiated BIT, Continuous BIT
- Extended temperature versions (E-Series, K-Series):
 - E: -25°C to +70°C, air-cooled
 - K: -40°C to +85°C, humidity sealant, air-cooled
- Ruggedized versions (RA-Series, RC-Series):
 - RA: -40°C to +75°C, conformally coated, air-cooled
 - RC: -40°C to +85°C, conformally coated, conduction-cooled (at card edge) to ANSI/VITA 30.1-2002
- Single slot
- Support for Linux®, Windows® 7, Windows® Embedded Standard 7, Windows® XP, Windows® XP Embedded, Windows® Server 2008, QNX®, VxWorks®, Solaris™ and LynxOS®

VME/VXS Single Board Computer

- VME/VXS SBC utilizing the 2nd generation Intel® Core™ processor:-
 - air-cooled
 - optional rear transition module
- supports VITA 41.4 and VITA 41.6 fabric interfaces
- for ruggedized versions, see separate datasheets:-
 - rear plug compatible
 - conduction-cooled: VX 81x/09x-RC
 - air-cooled: VX 81x/09x-RA

Central Processor

- 4-core 2.1 GHz Intel® Core™ i7-2715QE processor
- 2-core 1.5 GHz Intel® Core™ i7-2610UE processor, 2.2 GHz Intel® Core™ i7-2655LE processor or 2.5 GHz Intel® Core™ i5-2515E processor
- common processor features are:-
 - 32nm process technology
 - 1333 MHz Front Side Bus
 - Intel 64 technology (64-bit computing)
- shared Last-Level on-die cache:
 - 2.1 GHz Intel Core i7-2715QE - 6 Mbytes
 - 1.5 GHz Intel Core i7-2610UE - 4 Mbytes
 - 2.2 GHz Intel Core i7-2655LE - 4 Mbytes
 - 2.5 GHz Intel Core i5-2515E - 3 Mbytes
- utilizes Intel® Series 6 mobile class chipset with Intel® QM67 Platform Controller Hub (PCH)

SDRAM

- supports up to 16 Gbytes DDR3-1333 ECC SDRAM:-
 - up to 16 Gbytes soldered
 - peak bandwidth of 20 Gbytes/s
 - dual channel architecture
- accessible from processor or VME/VXS interfaces

Fabric Interfaces

- 2 x4 PCI Express® VXS data plane (VITA 41.4), including DMA and transparent/non-transparent modes:-
 - implemented by PCI Express® switch via dual x4 PCI Express links (Gen 1 or Gen 2)
- build option to support XMC site 1 Pn6 interface to VXS data plane via an active multiplexer:-
 - 1 x4, 2 x4 or 1 x8 fabric links
 - up to 6.25 Gbits/s
- 2 x 1000 Base-BX control plane (VITA 41.6):-
 - implemented by Intel® 82580EB Ethernet Controller via x2 PCI Express link (Gen 2)
- fabric interfaces via optional P0 rear I/O

Ethernet Interfaces

- 2 x 10/100/1000 Mbps Ethernet channels:-
 - implemented by Intel® 82580EB Ethernet Controller via x2 PCI Express link (Gen 2)
 - access via front panel RJ45 and via P0 I/O

Mass Storage Interfaces

- 2 x SATA600 channels via P0 rear I/O
- 2 x SATA300 channels via P2 rear I/O*
- optional 2.5-inch drive, occupies PMC site 2
- SATA to EIDE interface supports on-board CompactFlash™ site

PMC/XMC Interfaces

- 2 x PMC/XMC sites:-
 - PMC sites support 32/64-bit, 33/66/100MHz PCI-X operation and PCI 3.3V or 5V signaling
 - XMC sites support x8 PCI Express link (Gen 1 or Gen 2)
 - XMC sites powered from 5V supply
- PMC/XMC site 1 I/O via front panel and utilizes Pn4 via P2 rear I/O (VITA 35)
- PMC/XMC site 2 I/O via front panel

Serial Interfaces

- 2 x serial channel interfaces:-
 - 1 x RS232 accessed via a 60-way high-density connector on front panel
 - 1 x RS232/RS422/RS485 via P2 rear I/O*
- 16550 compatible UARTs

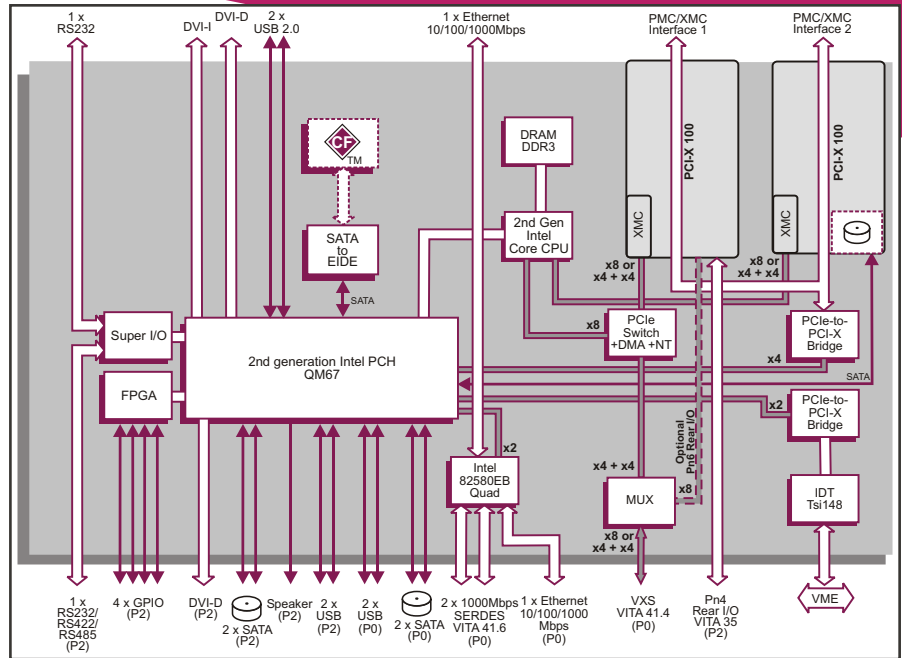

Dual Display Graphics Interfaces

- implemented by Intel chipset
- independent dual display channels:-
 - DVI-I and DVI-D interfaces, via 60-way high-density connector on front panel
 - DVI-D interface, via P2 rear I/O*
- digital, up to 1600 x 1200, 16M colors
- analog, up to 2048 x 1536, 16M colors
- support for Microsoft® DirectX 10
- support for OpenGL 2.0, Windows and Linux

Other Peripheral Interfaces

- PC-compatible Real Time Clock
- 6 x USB 2.0 interfaces:-
 - 2 accessed via a 60-way high-density connector on front panel
 - 2 via P2 rear I/O*
 - 2 via P0 rear I/O
- 4 x GPIO via P2 rear I/O* with processor interrupt capability
- watchdog timer
- legacy speaker interface
- 1 x 32-bit Long Duration Timer with processor interrupt capability

Software Support

- support for Linux®, Windows® 7, Windows® Embedded Standard 7, Windows® XP, Windows® XP Embedded, Windows® Server 2008, VxWorks®, QNX®, Solaris™ and LynxOS®

Firmware Support

- Insyde Software InsydeH20™ BIOS:-
 - includes Compatibility Support Module
- based upon Intel® Platform Innovation Framework for EFI
- comprehensive Power-On Self-Test (POST)
- LAN boot firmware included

BIOS EPROM

- 8 Mbyte of BIOS SPI Flash EPROM

Optional Built-In Test (BIT) Support

- Power-on BIT (PBIT)
- Initiated BIT (IBIT)
- Continuous BIT (CBIT)

Safety

- PCB (PWB) manufactured with flammability rating of 94V-0

VME/VXS Interface

- compatible with VME64x and VXS:-
 - P1 and P2 connectors compatible with VME64x and VXS systems
 - P0 connector compatible with VXS systems
- optional VXS P0 provides VITA 41.4 and VITA 41.6 fabric interfaces
- VME bus interface implemented using IDT Tsi148 PCI-X VME64/VME320 bridge
- VME Master/Slave
- A64/A32/A24/A16/D64/D32/D16/D8(E0), MBLT64, 2eSST and 2eVME support
- auto system controller detect
- full interrupter/interrupt handler support

Electrical Specification (Estimated)

- requires 5V supply only, +5/-3%
- +5V @ 10A (typical current figure with 2.2 GHz Intel Core i7-2655LE processor, 8 Gbytes SDRAM)
- 3.3V, +12V and -12V supplies not utilized

Environmental Specification

- operating temperatures:-
 - 0°C to +55°C (N-Series)
 - -25°C to +70°C (E-Series: 2.2 GHz or 1.5 GHz)
 - -40°C to +85°C (K-Series: 1.5 GHz)
- storage temperature: -40°C to +85°C
- 5% to 95% Relative Humidity, non condensing (operating or storage):-
 - K-Series includes humidity sealant

Mechanical Specification

- 6U form-factor
- single slot, front panel width 0.8 inch (20.3mm)
- utilizes 160-way connectors for P1 and P2
- optional VXS P0 connector
- IEEE 1101.10 handles
- shock: 20g, 11ms, ½ sine
- vibration: 5Hz-2000Hz at 2g, 0.38mm peak displacement

*P2 rear I/O : A P2 connector build option is supported to isolate the signals on P2 rows Z and D, this allows the board to be installed in special backplanes, e.g. Race+®

ORDERING INFORMATION

Order Number	Product Description (Hardware)
VX 815/09x-yz	4-core Core i7 processor
VX 813/09x-yz	2-core Core i7 or Core i5 processor

For the order number suffix (yz) options please contact your local sales office:
 Where y = P0/Pn6 configurations
 y - VXS P0 and Pn6 configurations
 Where z = SDRAM size
 z - up to 16 Gbytes