

## SINGLE BOARD COMPUTER with MULTI-FUNCTION I/O

### FEATURES

- SBC with multi-function I/O in a single 6U VME slot
- Automatic background BIT (module-dependant)
- VME Bus and/or Dual Gigabit Ethernet Interfaces
- Front and/or Rear I/O Support
- Designed for Commercial and Rugged applications
- Software Support Kit(s) and Driver(s) are available

### Processor Options

- **Freescal PowerPC MPC8536 @ 1.25 GHz Processor**
  - 1 GB SDRAM
  - 256 MB Flash
  - Dual Gigabit Ethernet
  - Serial/USB/SATA/PCIe/SD Support
  - VxWorks 6.x BSP
- **Analog Devices (ADI) BF533 @ 500 MHz Processor**
  - Extremely Low Power High Performance Processor
  - Windows PC Development – ADI Visual DSP++
  - Ethernet, RS232, USB, I<sup>2</sup>C, Differential and TTL I/O

Conduction Cooled



Convection Cooled

### DESCRIPTION

The 64EP3 is a single slot, 6U VME, low-power/high-performance Single Board Computer (SBC) with configurable multi-function I/O. Powered by a choice of Freescale's 1.25 GHz MPC8536 PowerPC (U3) or Analog Devices' 500 MHz BF533 (U2) processor modules, the 64EP3 offers an extremely low power, cost-conscious SBC solution for today's demanding, space-constrained and resource limited embedded systems. Four I/O module slots enable integrators to mix-n-match a variety of I/O and communication functions. The functions include Digital I/O (Discrete, Differential, TTL), Analog I/O (A/D, D/A, RTD, Strain Gage), Motion Control and Sensor Interfaces (Synchro/Resolver/LVDT/RVDT Measurement and Simulation, Encoder/Counter), and Communication Interfaces (RS-232/422/485, MIL-STD-1553, CANBus and ARINC 429/575). The 64EP3 SBC configured with up to four modules allows systems integrators to confidently manage monitor and process a host of sensor interfacing requirements with NAI's flexible, leading-edge, fully programmable and continuous background built-in-test (BIT) enabled I/O function modules.

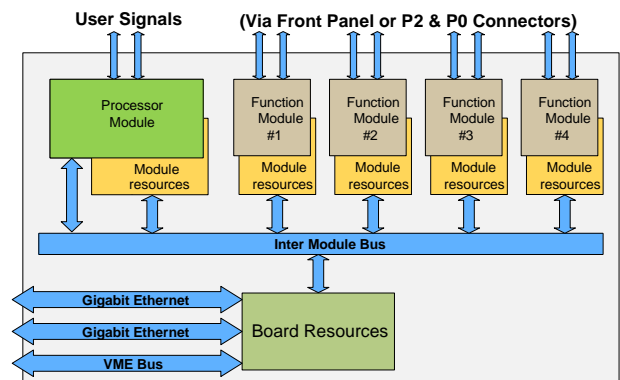

The 64EP3 SBC with multi-function I/O and full complement of I/O libraries and drivers are ideally suited for a multitude of commercial and rugged embedded processing and I/O systems. The 64EP3 SBC with Master VME Bus capability may be utilized with other NAI high-density, multi-function I/O boards to provide a complete, expandable, low power/high performance, programmable solution for sensor and communication data acquisition, management, processing and distribution. All I/O sensor data is available on the VME Bus or Gigabit Ethernet.

Advantages of using the 64EP3 SBC for board or system-level solutions:

- Process and control of I/O functions without the need of a separate SBC or mission computer
- Direct processing and control of I/O functions via MIL-STD-1553, RS232/422/485, CANBus, ARINC 429/575 and/or other functions
- Reduction of raw data to offload main mission computer—enabling performance of customer-specific algorithms such as FFT and digital filtering
- Ability to manage and process control/servo loops without mission computer intervention

## GENERAL BOARD SPECIFICATION

Power – +5VDC

•Operating Temp – 0° C to 70° C or -40° C to 85° C

•Size – 233mm x 20mm x 160mm (6U)

### PROCESSOR MODULES

Processor	Module	Flash	SDRAM	Frequency	Software Support
PowerPC MPC8536	U3	256MB	1GB DDR2	1.25 GHz	Wind River BSP / VxWorks 6.x / Library
ADI Blackfin® BF533	U2	8MB	512KB	500 MHz	ADI Visual DSP++ / Function Library

### AVAILABLE FUNCTION MODULES

Notes: 1 – Indicates wide selection (See part number in Operations Manual.)

Module	Module	Channels	Input Scaling	Resolution	Accuracy (±)	Sampling (programmable)
A/D Converter	C1	10	±1.25,2.5,5 or 10 VDC	16 bit	0.05% FS	200 KHz max
	C2	10	±5,10,20 or 40 VDC	16 bit	0.1% FS	200 KHz max
	C3	10	0-25 mA	16 bit	0.1% FS	200 KHz max
	C4	10	±6.25,12.5,25 or 50 VDC	16 bit	0.1% FS	200 KHz max
	CA	10	(Channels 1-6 are C2 type and Channels 7-10 are C3 type)			
D/A Converter	F1	10	±10 or 0-10 VDC	16 bit	0.05% FS	15µs max
	F3	10	±5 or 0-5 VDC	16 bit	0.05% FS	10µs max
	F5	4	±25 or 0-25 VDC	16 bit	0.05% FS	10µs max
	J3	10	±1.25 or 0-1.25 VDC	16 bit	0.05% FS	10µs max
	J5	10	±2.5 or 0-2.5 VDC	16 bit	0.05% FS	10µs max
	J8	4	±20 to ±100 VDC	16 bit	0.15% FS	350µs max
D/S	Module 6 <sup>1</sup>	Channels 3	Frequency 47 Hz – 10KHz	Resolution 16 bit	Accuracy (±) ±0.1°	Power 0.25 VA/channel
DLV	Module 5 <sup>1</sup>	Channels 3	Frequency 47 Hz – 10KHz	Resolution 16 bit	Accuracy (±) 0.2% FS	Power 0.1 VA/channel
Discrete I/O	Module K6	Channels 16	Input Range 0 – 60 VDC	Output Range 0 – 60 VDC	Programmable Input or Output	
TTL	Module D7	Channels 16	Input Range 0 – 5.5 V	Output level TTL/CMOS	Programmable Input or Output	
Differential Transceiver	Module D8	Channels 11	Input Range (422) -10V to +10V	Input Range (485) -7V to +12V	Output Range (422/485) -0.25V to +5V	
Encoder	Module E7	Channels 4	Signal Voltage 24 VDC	Resolution 32 bit	Counter Modes SSI, Encoder, Quadrature	
LVDT	Module L <sup>1</sup>	Channels 4	Frequency 360 Hz to 20 KHz	Resolution 16 bit	Accuracy (±) 0.025% FS	Interface 2 or 3/4 wire
S/D	Module S <sup>1</sup>	Channels 4	Frequency 50 Hz to 20 KHz	Resolution 16 bit	Accuracy (±) 1 arc-min	Tracking Rate 190 RPS
RTD	Module G4	Channels 6	Update rate 16.7 Hz/channel	Resolution 16 bit	Accuracy (±) 0.05% FS	Interface 2, 3 or 4 wire
Strain Gage	Module G5	Channels 4	Update rate 2.3 Hz – 2.4 KHz	Resolution 16 bit	Accuracy (±) 0.1% FS	Interface Conventional 4-arm bridge
ARINC 429/575	Module A4	Channels 6	Frequency 100 KHz or 12.5 KHz	Input/output RX/TX	Message Buffer 256 word Tx/Rx	
MIL-STD-1553	Module N7	Channels 2	Operational Modes BC,RT, BM, BM/RT	Onboard RAM 128Kbyte per ch	Coupled Transformer	
	Module N8	Channels 2	Operational Modes BC,RT, BM, BM/RT	128Kbyte per ch	Direct	
CANBus	Module P6	Channels 4	CAN protocol Version 2.0B	Message Buffer 16K RX/TX	Data rate (Prog) 1 Mb/s max.	Notes Bosch® IP Core
RS-232/422/485	Module P8	Channels 4	Communication Async/Sync	Data rate (Sync) 4 Mbits/s per ch.	Data rate (Async) 1 Mbit/s per ch	Tx/Rx Buffer 32 KB Part modem
Reference	Module W <sup>1</sup>	Channels 1	Frequency 47 Hz – 10KHz	Accuracy +/- 3%	Voltage 2 – 115 VRMS	Power 6 VA

### PART NUMBER DESIGNATION

64EP3 – XX XX XX XX XX X X X –XX

Slot # 1 2 3 4 5

#### MODULE (SLOT) 1 through 4 DEFINITION

Enter Function Module Designation (i.e.C1) for each slot (1 through 4; enter "Z0" if slot is not populated)

#### MODULE (SLOT) 5 DEFINITION

Enter Processor Module Designation (i.e. U2 or U3)

#### MECHANICAL

F = Front Panel and Rear I/O (P2 & P0)    A = VME64 Blank Front Panel with Rear I/O (P2 & P0)  
 S = Front Panel Rear P2 I/O (No P0)        R = VME64 Blank Front Panel with Rear P2 I/O only (No P0)  
 P = Rear I/O only (P2 & P0)                B = VME64 Front Panel and Rear I/O (P2 & P0)  
 G = Rear P2 I/O only (No P0)              T = VME64 Front Panel and Rear P2 I/O only (No P0)  
 W = P with Wedge locks                    D = VME64 Blank Front Panel, Low profile extractors with Rear I/O (P2 & P0)

#### ENVIRONMENTAL

C = 0 TO 70 °C  
 E = -40 TO +85 °C  
 H = E with conformal coating  
 K = C with conformal coating

#### DUAL ETHERNET MOTHERBOARD (MB) ONLY

0 = No Ethernet  
 1 = MB Port A to Front Panel  
 2 = MB Port A to Rear P0  
 3 = MB Port A to Front and MB Port B to P0  
 4 = MB Port A and Port B to Rear P0

#### Combined w/ SLOT 5 Ethernet Options

(Specific w/ module type Ethernet options only (i.e. U3)  
 A = MB Port A to Front and U3 Port B to P0  
 B = MB Port A to P0 and U3 Port B to P0  
 C = U3 Port A to P0 and U3 Port B to P0

#### SPECIAL OPTION CODE (or leave blank)

## Processor (Module U2) Blackfin® Processor and General Purpose I/O Resource for User Operational Programs and Control

Processor:	The BF533, from the ADI Blackfin family, offers support for overall system processing. The U2 is an extension of the multifunction board architecture which uses Blackfin processors to implement the motherboard, module and signal processing functions. The Blackfin is an ideal choice for this use due to its wide application and availability of third party software and design services.
FPGA:	A moderate scale FPGA (Altera Cyclone II family) is added to provide additional flexibility for system functions.
Processor clock rate	500 MHz
Flash Memory:	8 MB for program and data storage
Ferro-Electric RAM:	8 KB for non volatile data storage
SDRAM:	16 MB for program execution
SRAM:	512KB for real time cache
Power:	5V @ 1150 mA (Est. / Typ. Duty cycle)
Weight :	2 oz. (57g)

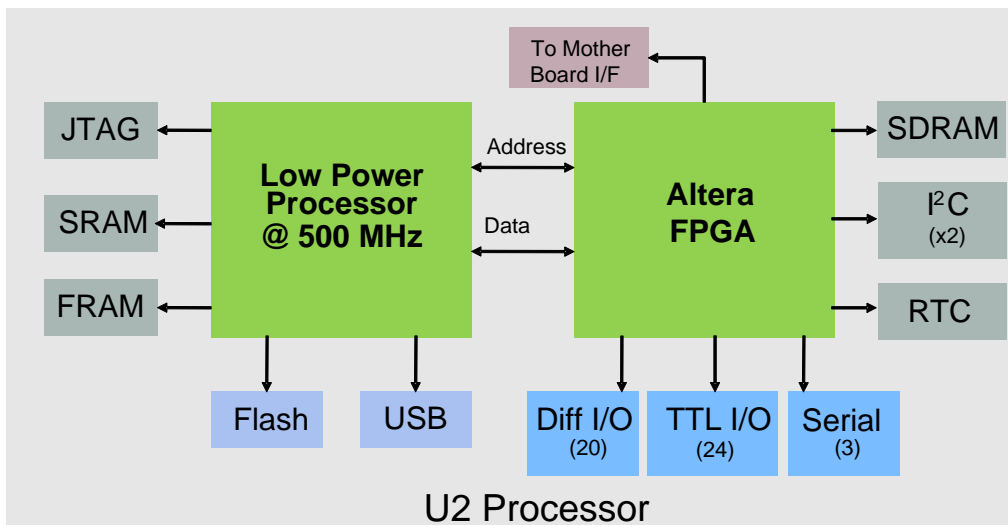

U2 Processor Module Block Diagram

### U2 Processor Description

Based on the Analog Devices Blackfin® BF-533 DSP processor, users can confidently take advantage of the powerful Analog Devices, Inc. (ADI) Visual DSP++ Development Environment. Boards fitted with the U2 Processor allow users to develop application code in support of their I/O and communication intensive application without the need for a separate Single Board Computer. The U2 coupled with NAI's extensive I/O function capabilities and software library support offers developers a real time embedded system environment. Additionally, this low power high performance solution can interface directly to the I/O, perform embedded algorithms and communicate directly to system and sub-system computers. Operating system run-time and overhead are reduced due to direct DSP control. Additional core interfaces added to the FPGA allow for a flexible communication interface selection for controlling I/O specific modules. Reference U2 Programmer's guide for detailed operation documentation.

### User Requirements/Utility Library

- Analog Devices Visual DSP++ 4.5 (or later version)
- Blackfin Emulator
- NAI I/O and Communications Library support

## Processor (Module U3)    **PowerPC Processor and General Purpose I/O Resource for User Operational Programs and Control**

Processor:	The MPC8536, high-performance member of the PowerQUICC III™ processor family combines a computation-intensive super-scalar Power Architecture™ processor core with high-performance system peripherals and advanced power management techniques. Integrates SATA, USB, multi-lane PCI Express, Gigabit Ethernet, and DDR memory to increase data bandwidths, reduce valuable board real estate, and lower overall power consumption.
Processor Clock Rate:	1.25 GHz
NAND Flash:	256 MB for data storage
Ferro-Electric RAM:	8 KB for non-volatile data storage
SDRAM:	1 GB for program execution
SPI FLASH :	16 MB for program and data storage
Power:	5V @ 1650 mA (Est. / Typ. Duty cycle)
Weight :	2 oz. (57g)

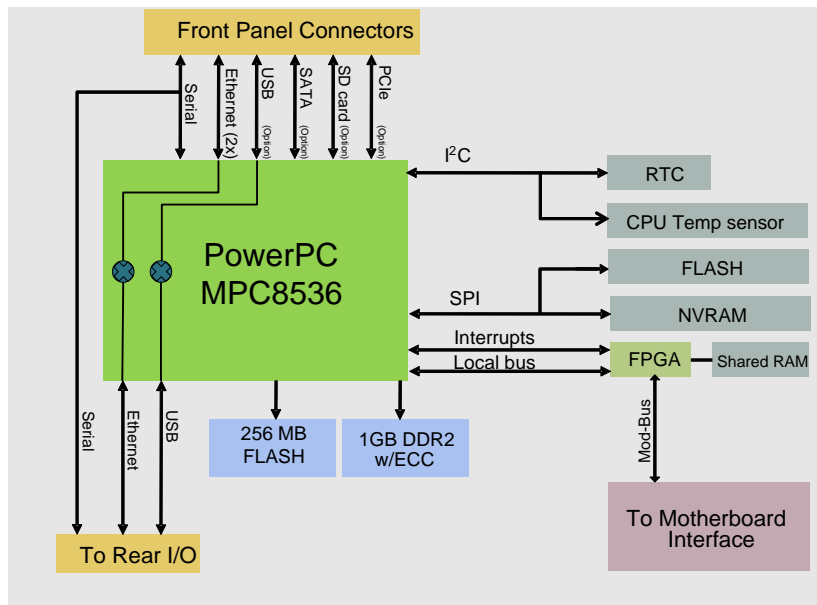

U3 Processor Module Block Diagram

### **U3 Processor Description**

Based on FreeScale™ MPC8536 processor, users can confidently take advantage of the familiar VxWorks RTC environment for developing control and application software. Boards fitted with the U3 Processor allow users to develop application code in support of their I/O and communication intensive application without the need for a separate Single Board Computer. The U3 coupled with NAI's extensive I/O function capabilities and BSP/library support offers developers a real time embedded system environment. Additionally, this solution can interface directly to the I/O, other cards on the system bus (Bus-Master capability), perform embedded algorithms and communicate directly to system and sub-system computers. Operating system run time and overhead are reduced due to direct processor control.

### **User Requirements/Utility Library**

- VxWorks 6.x Development Environment
- NAI U3 VxWorks 6.x BSP
- NAI I/O and Communications Library support

### **UNITRONIX Pty Ltd**

PO Box 486, Morisset NSW 2264  
**NSW:** Tel: 61 2 4977 3511 Fax: 61 2 4977 3522  
**WA:** Tel: 61 8 9455 2424 Fax: 61 8 9455 2458  
 unitsyd@unitronix.com.au www.unitronix.com.au