

56SQ1

- AC/DC Power Supply
- VME
- Up to 430 Watts
- Ruggedized



Features

- High Power Density, Low Profile Packaging
- ESS Screening (Burn-In) and Temperature Cycling
- Designed and Manufactured Per NAVMAT Guidelines
- EMI Filtering Designed to MIL-STD-461E
- Remote Error Sensing
- Remote Digital (TTL) Turn On/Off
- Transient Protection per MIL-STD-1399
- VME and cPCI with ANSI/VITA Signaling (AC Fail & Sys Reset)
- Holdup Time
- Current Share
- Power Factor Correction

Contents

<i>Specifications</i>	1
<i>Electrical</i>	1
<i>Physical/Environmental</i>	2
<i>Output Power (Table 1)</i>	3
<i>Input Pin-Out (Table 2)</i>	3
<i>Output Pin-Out (Table 3)</i>	3
<i>Connectors (Table 4)</i>	3
<i>Ordering Information</i>	4
<i>Output Diagram Example</i>	5
<i>Mechanical Layout (with dimensions)</i>	6

Description

The NAI 56SQ1 is a high power density, low profile VME power supply which accepts a 115/208Vac, single phase input. The 56SQ1 is ideally suited for VME & CPCI applications and is **designed to fit within a standard 6U rack**. All NAI power supplies are designed and qualified to the most stringent performance and environmental requirements.

Electrical Specifications

Input Characteristics:

Input	115/208 Vac, Single Phase nominal; Input voltage range 100Vac to 242Vac; Auto-Sensing
Frequency Range	47Hz to 440Hz
EMI/RFI Characteristics	Designed to meet the requirements of MIL-STD-461E – CE102, CS101, CS114 a & b, CS116 – Note: Using shielded cable with 60db attenuation input & output lines
Input Transient Protection	Per MIL-STD-1399 sec.300A; For nominal 115 VAC input
Power factor	.90 min

DC Output Characteristics:

Output Power	See Table 1
Output Voltage	See Table 1
Efficiency	75% typical
Line Regulation	Within 0.1% or 10mv (whichever is greater) for low to high line changes at constant load
Load Regulation	0.1% or 10mv (whichever is greater) for 0 to 100% of rated load at nominal input line; with remote sense

PARD (Noise and Ripple)	50mv p-p max. Measurements are made with a 20 Mhz bandwidth instrument connected on load wires < 5 inches from power supply and terminated with 1uF capacitors across load lines
Load Transient Recovery	Output voltage returns to regulation limits within 0.5 msec, half to full load
Load Transient Under/Overshoot	5% of nominal output voltage set point (1.4v max)
Short Circuit Protection	Protected for continuous short circuit with automatic recovery
Current Limiting	All outputs 105% to 130%
OverVoltage Protection	Automatic electronic shutdown if outputs exceed 125% ±10%
Holdup Time	20 milliseconds standard; 50 milliseconds optional
Remote Error Sensing	Sensing pins compensate for up to 0.5-volt drop on 5Vdc & 3.3Vdc output leads
Isolation Voltage	1000 VDC input to output and input to case; 100 VDC output to case.
Insulation Resistance	50 Megohm at 50 VDC
Current share (All Outputs) <i>Optional</i>	Can be used for adding additional power or for redundancy

Signal Types:

PFW	Open collector output capable of sinking 50 mA. Output will be low (conducting) during normal operation and it will go high prior to the outputs dropping out
Enable	$V_{IL} = 1V$ max, $V_{IH} = 3V$ min. Input has 1K Pull-up resistor. Low enables the switched outputs. High or Float will disable the switched outputs.
DCGood	Open collector output capable of sinking 50 mA. Output will be low (conducting) when outputs are within 5% of nominal value.
OC	Open collector output capable of sinking 50 mA. Output will be low (conducting) when outputs are not in over-current limit.
Share Ok <i>OPTIONAL</i>	Provides status of outputs during current share operation
AC Fail (ANSI/VITA) <i>OPTIONAL</i>	Signal from power supply indicating status of input
System Reset (ANSI/VITA) <i>OPTIONAL</i>	A signal from power supply indicating a reset (such as a power up) is in progress
Reset (ANSI/VITA) <i>OPTIONAL</i>	Input to power supply via a switch; resets the system without a power off applied

Physical/Environmental Specifications

Temperature Range	(Standard configurations) Operating: -40°C to +85°C at 100% load (Temperature measured at baseplate; conduction via baseplate only); Storage: -55°C to +125°C
Temperature Coefficient	0.01% per °C
Shock	25 G's each axis, per MIL-STD-810C, Method 516.2, Procedure 1
Vibration	Per MIL-STD-810C, Method 514.2, Procedure 1A. <i>Vibration per NAVMAT guidelines performed on an AQL basis; 100% vibration screening available</i>
Humidity	95% at 71°C per MIL-STD-810C, Method 507.1 (non-condensing)
Altitude	40,000 feet per MIL-STD-810C, Method 504.1, Category 6 Equipment
Dimensions	See Sheet 6
Salt Fog	Per MIL-STD-810C, Method 509.1
Sand/Dust/Fungus	Per MIL-STD-810C
Enclosure	Aluminum housing to aluminum Baseplate
Finish	Chemfilm
Interface	Connector per Table 4
Weight	4lbs Typical

Table 1. Output Power

Designation	Volts	Amps	Description
V1	+5.0	30	Switched
V2	+12	4	Switched
V3	-12	4	Switched
V4	+3.3**	30	Switched
V5*	+5	1	Standby *
V5*	+12	0.3	Standby *

*Note: Unit is available with either +5vdc or +12vdc Standby output. See ordering information of sheet 4.

**This voltage can be configured to +3.3, +5, +12, +15, +24 or +28vdc @ up to 150 watts.

Table 2. Input Pinout Designations (J1)

Pins	Signal Name
1, 2, 9, 10	Line Input
4, 5, 12, 13	Neutral
7, 8, 15	Ground
3, 6, 11, 14	Reserved

Table 3. Output Pinout Designations (J2)

Pin(s)	Signal	Pin(s)	Signal
A1, A2, A3	Out (V1)	8	V2 Current Share
A4, A5	V1, V2, V3 & V5 Rtn	9	V1 Current Share
A6	V4 Rtn	10	V4 Current Share
A7	Out (V4) *note1	11	V3 Current Share
1	Enable	12	Standby Out (V5)
2	DCGood	13	Out (V3)
3	+3.3 DCGood / System Reset **note2	14	V3 Sense
4	PFW / ACFAIL**note2	15	V2 Sense
5	V4 Sense	16	Not used
6	V1 Sense	17	Out (V2)
7	Sense Rtn		

*Note 1: V4 is isolated from other outputs. The return line can be connected at either the system motherboard or at the unit connector. The sense return is internally connected for the V4 output and becomes common when all other grounds are connected together.

** Note 2: ACFail and System Reset are only available with ANSI/VITA signaling option in place of standard signaling

Table 4. Connectors

Connector/Pins	Part Number - Series
Input Unit Connector	DAMM15P
Input Mating Connector*	DAMM15S
Output Unit Connector	DDMG24HSJA197
Output Mating Connector*	DDM24W7P
Output Connector Pins*	DM53745-110

*Not Supplied

Ordering Information for 56SQ1 (430 Watt VME Power Supply)

56 **S** **Q1** **M** **0** - **XX**
CODE (See Code Table Below)

OPTIONS: 0 = +5vdc @ 1A Standby Output
 1 = +12vdc @ 0.3A Standby Output

RELIABILITY: COTS Mil-Type

OUTPUT: Quad output, plus standby

WATTAGE: S = 400 W

SERIES: 56 = AC/DC

Code Table

Code	General Code Description	Unit Height	Temp Range
01	<ul style="list-style-type: none"> Outputs: +5vdc @ 46 amps, +3.3vdc @ 33 amps, ±12vdc @ 2 amps each & -5vdc @ 1amp. 75 milliseconds holdup time at full power 	2.0"	0° to 50° C
02	<ul style="list-style-type: none"> Standard unit with optional Current share option installed 	1.6"	-40° to +85°C
03	<ul style="list-style-type: none"> Standard unit with optional ANSI/VITA signaling in place of standard signaling 	1.6"	-40° to +85°C
04	<ul style="list-style-type: none"> Outputs : +5.2vdc @ 30 amps, +3.3vdc @ 30A, ±12vdc @ 4A each and standby output of +5.4vdc @ 1A Optional ANSI/VITA signaling in place of standard signals 	1.6"	-40° to +85°C
05	<ul style="list-style-type: none"> Outputs of +5vdc @ 150 watts, +12vdc @ 48 watts, -12vdc @ 48 watts, +28vdc (isolated) @ 150 watts and +5vdc @ 1Amp standby. Current share option Optional ANSI/VITA signaling in place of std signals Includes 100% vibration screening 50 milliseconds of holdup time 	2.0"	-40° to +85°C
06	<ul style="list-style-type: none"> Outputs of +5vdc @ 10Amps, +12vdc @ 2Amps, -12Vdc @ 2Amps, +26Vdc @ 2Amps (unswitched) and +5vdc @ 1Amp standby. The +26v output remains on when other outputs are turned off via the enable and will remain on as long as there is sufficient input power. Standard signaling options, PFW, DCGood, Enable and OC Enable polarity is changed as follows: A high or an open will enable the switched outputs; a low disables the switched outputs 50 milliseconds of holdup time 	2.0"	-40° to +85°C

56SQ1 Output Diagram Example

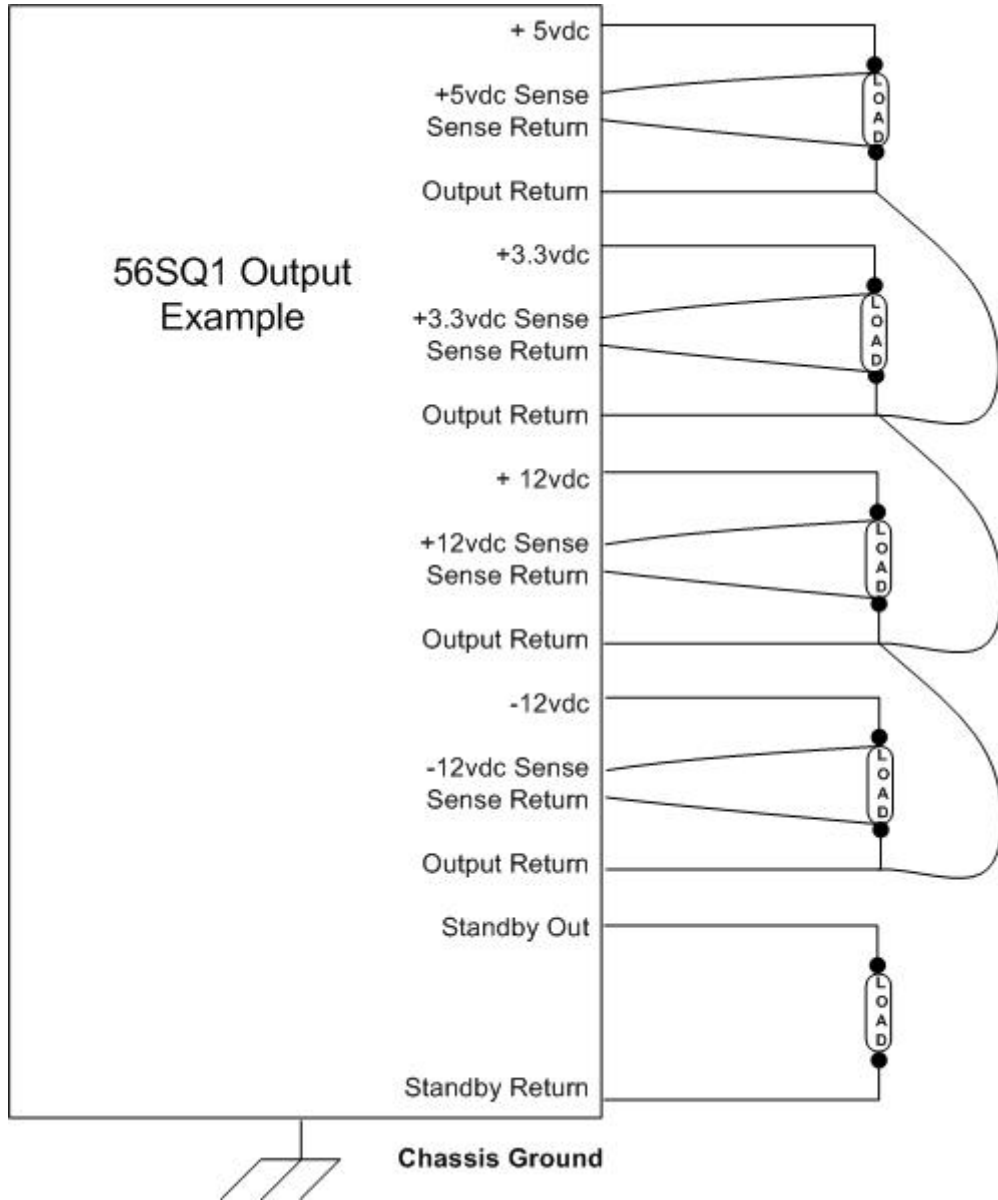

Mechanical Layout

Mechanical Dimensions 56SQ1

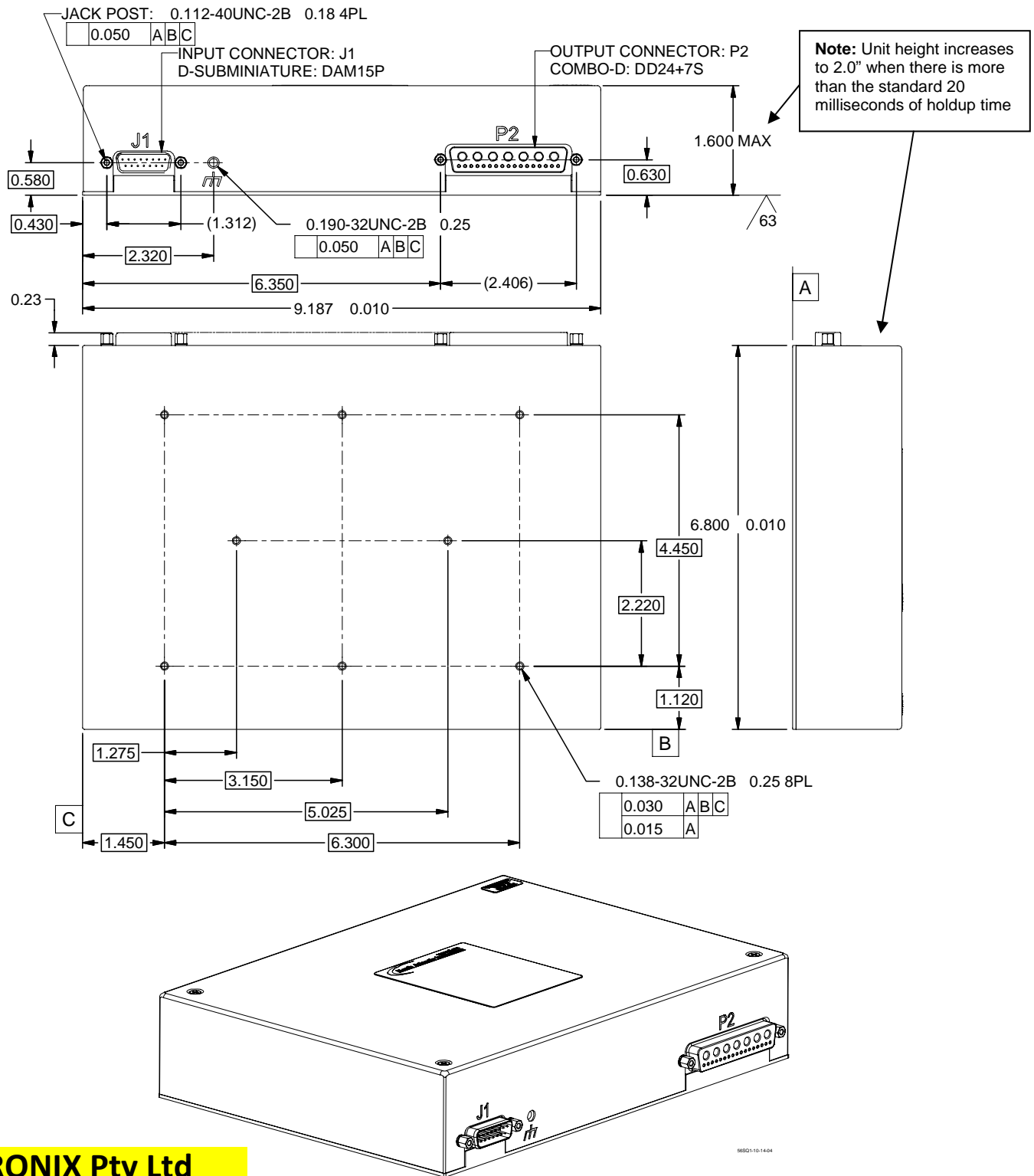

UNITRONIX Pty Ltd
 PO Box 486, Morisset NSW 2264
 NSW: Tel: 61 2 4977 3511 Fax: 61 2 4977 3522
 WA: Tel: 61 8 9455 2424 Fax: 61 8 9455 2458
 unitsyd@unitronix.com.au www.unitronix.com.au