

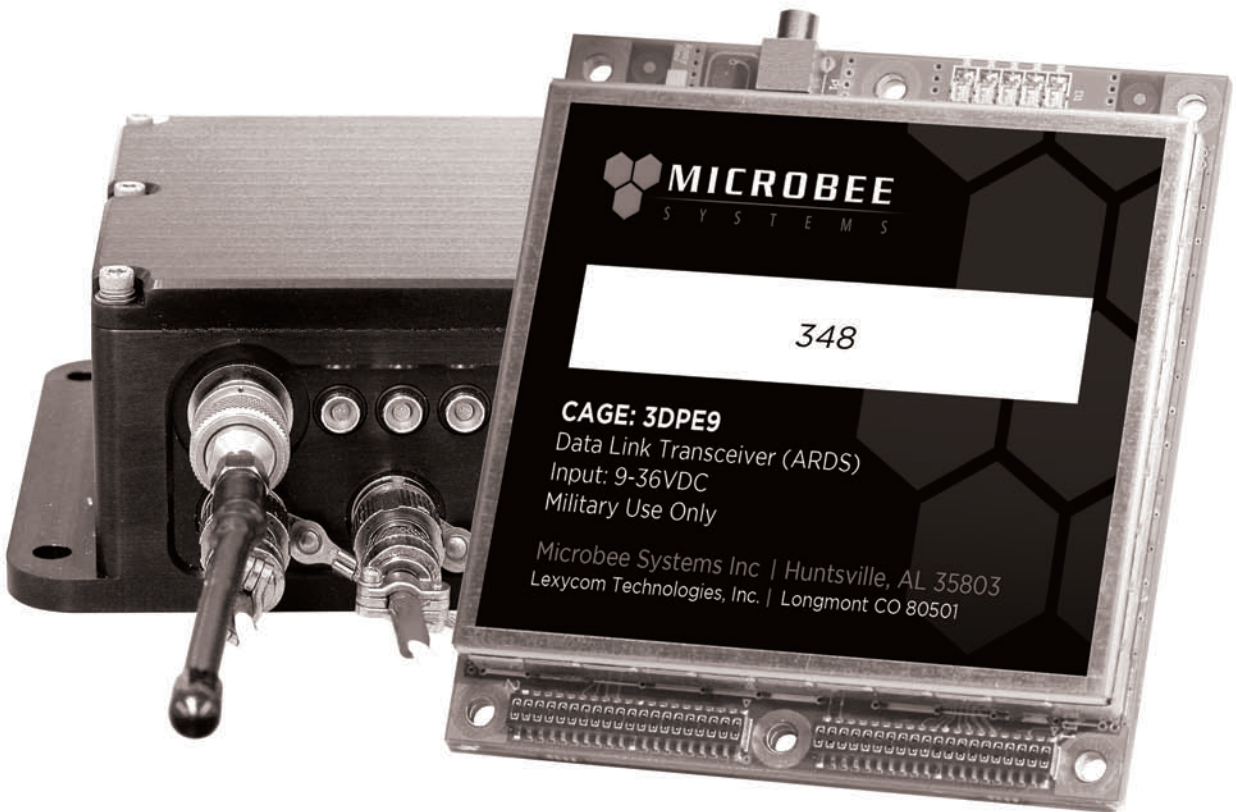

TELION 1300

SOFTWARE DEFINED DATA RADIO



TELION 1300

SOFTWARE DEFINED DATA RADIO

OVERVIEW

The Telion 1300 is a fully digital software-defined radio transceiver with a medium scale FPGA onboard for fully customizable SDR solutions. Supporting virtually any type of RF channel waveform, the Telion features Spread Spectrum Frequency Hopping (hops as fast as 100,000 times/second), Direct Sequence or Hybrid at 1350-1390 MHz with a frequency resolution of 25 kHz. RF channel throughput is adjustable according to the application needs from 2.4 kb/s to 1.3 Mb/s with a wide selection of digital data interfaces. The unit is available as an OEM Module, PC/104 Module or in a highly MIL Type Ruggedized Enclosure. The Telion-1300 is also equipped with an on-board encryption engine, randomizer, and encoder.



TELION 1300

SOFTWARE DEFINED DATA RADIO

SPECIFICATIONS

GENERAL CHARACTERISTICS

Frequency band of operation

1350-1390 MHz

RF channel throughput

Defined by the loaded software

-1.28634 Mb/s for ARDS waveform

-Other Waveforms 100 kb/s to 1.3 Mb/s

Signal OC-BW

Depends on the type of modulation chosen and RF bit rate selected. From 12.5 kHz to 2.6 MHz.

In ARDS-compliant mode:

-3 dB 800 kHz

-20 dB 1.8 MHz

-40 dB 5.8 MHz

-60 dB 10 MHz

Modulation types supported

Supports SOQPSK (ARDS-compliant), MSK, GMSK, FSK, AM, FM

Error correction

In ARDS-compliant mode:

Convolutional code, $r = 1/2$, G1 = G1-1011011; G2-1111001

On Rx - Viterbi, hard decision, $k = 7$

Error detection

Transceiver can support user-defined CRC protocol. Several standard protocols are supported;

CRC16 (by default)

CRC24 (ARDS-compliant, MIL-STD 188-184)

CRC32

Interleaving/De-interleaving

In ARDS-compliant mode:

36x47 matrix Interleaver/De-interleaver

TELION 1300

SOFTWARE DEFINED DATA RADIO

SPECIFICATIONS

GENERAL CHARACTERISTICS CONTINUED

Network topologies supported

TDMA (ARDS-compliant), Push-to-Talk, Point-to-Point, Point-to-Multipoint, proprietary TDMA (including Masterless TDMA)

RF Network security

The following parameters are user selectable, providing required network security:

- Hop Rate as fast as 100,000 times per second
- Fast frequency hopping option
- Number of data bytes within each RF packet
- Deviation/modulation index for the RF channel transmissions
- Hop table up to 128 frequency channels long; each frequency channel is user selectable

Encryption

Available cryptography (AES, DES, and 3DES algorithms)

Methods available to user to overcome in-band interference

User has ability to:

- Select fast frequency hopping vs. slow frequency hopping
- Select frequency channels for their network, which overlap the in-band interfering signal the least
- Select different hopping rate (including single channel operation)
- Select different number of data bytes per each RF packet

TRANSMITTER

Frequency band

1350-1390 MHz

Output power

Programmable with 1 dB steps, up to 1 Watt

Maximum duty cycle

In ARDS-compliant mode:

< 20%. Otherwise, up to 100% (either CW or modulated)

TELION 1300

SOFTWARE DEFINED DATA RADIO

SPECIFICATIONS

TRANSMITTER CONTINUED

Current in transmit mode at maximum output power

- 1.8A @ 4 VDC
- 1 A @ 6 VDC
- 500 mA @ 12 VDC

RECEIVER

Frequency band

1350-1390 MHz, 25 kHz channel spacing

Sensitivity

In ARDS mode:

- 97 dBm @ 10^{-4} (no FEC)
- 102 dBm @ 10^{-4} (with FEC)

In Proprietary modes:

- 110 dBm @ 10^{-4} (no FEC, 130 kbps)
- 97 dBm @ 10^{-4} (no FEC, 1.3 Mbps)

Frequency Stability

<1.5 ppm

Demodulation techniques

In ARDS-compliant mode:

Coherent

In Proprietary modes:

Depends on the type of the signal desired for the communications.

Maximum input signal level

At least 0 dBm (sinusoidal signal of this amplitude within the frequency band of transceiver's operation will not result in permanent damage of the transceiver's hardware).

TELION 1300

SOFTWARE DEFINED DATA RADIO

SPECIFICATIONS

RECEIVER CONTINUED

RF selectivity

- 3 dB 40 MHz
- 20 dB 72 MHz
- 60 dB 120 MHz

Current in full receive mode

- 350 mA @ 4.5 VDC
- 250 mA @ 6 VDC
- 125 mA @ 12 VDC

1st IF Selectivity

- 3 dB 2.6 MHz
- 20 dB 4.5 MHz
- 60 dB 12 MHz

2nd IF Selectivity

In ARDS mode:

- 3 dB 900 kHz
- 20 dB 1.98 MHz
- 40 dB 5.4 MHz
- 60 dB <6.5 MHz

In Proprietary mode:

Reconfigurable and determined by the characteristics of the digital filters.

Image rejection

80 dB

Spurious rejection

60 dB

TELION 1300

SOFTWARE DEFINED DATA RADIO

SPECIFICATIONS

ELECTRICAL + MECHANICAL CHARACTERISTICS

Input voltage range

9-36 VDC

Operating temperature range

-40°-+80° C

Humidity

Up to 95%, non-condensing

RF connector

OEM Module & PC/104, MCX, Enclosure, TNC

Data connectors

Board-level transceiver provides 30-pin high density data connector, 3.3V CMOS

Data interfaces

Serial, SDLC, Ethernet Ports; IO is not 5V Tolerant

Port 1

ARDS-compliant mode

CDU operation, menu driven, asynch, NRZL, 2-line operation, 19200-8-N-1 fixed settings.

Can be used for software updates.

PTT mode

Diagnostics port, asynch, NRZL, 2-line operation, command driven, SMNP-like command set., 57600-8-N-1 fixed settings.

Other

Secondary data port or diagnostics port, transparent or command-based operation, up to 921.6 kb/s, various parity, number of databits, and number of stop bits.

Port 2

ARDS

Data port, SDLC/RS232 switchable (non-dynamic, defined at power-up).

SLDC, 806.4 kbs.

PTT

Diagnostics port, asynch, NRZL, 2-line operation, command driven, SMNP-like command set, 57600-8-N-1 fixed settings.

Other

Secondary data port or diagnostics port, transparent or command-based operation, up to 921.6 kb/s, various parity, number of databits, and number of stop bits.

TELION 1300

SOFTWARE DEFINED DATA RADIO

SPECIFICATIONS

ELECTRICAL + MECHANICAL CHARACTERISTICS

Data interfaces

Ethernet Port (optional)

10/100Base-T, full/half duplex, MDI/MDI-X auto crossover

In the ARDS-compliant mode some of the IO lines are used as follows:

- TransmitBlinking Pulse
- Select SDLC/RS232
- TimeSlot Pulse

In PTT and masterless-TDMA modes one of the IO lines is used for 1PPS input.

Programming the transceiver

Via CDU/Diagnostics port using SNMP-like protocol. Configuration software is included.

Dimensions (board level)

3.18" x 2.89" x 0.47"

ENCLOSURE

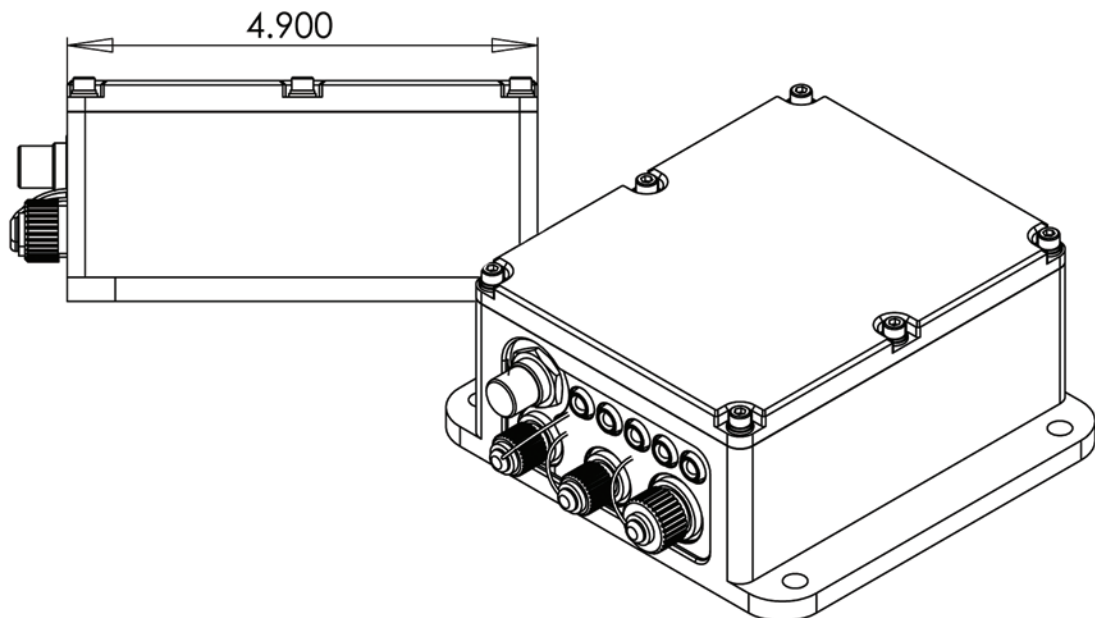

TELION 1300

SOFTWARE DEFINED DATA RADIO

ENCLOSURE

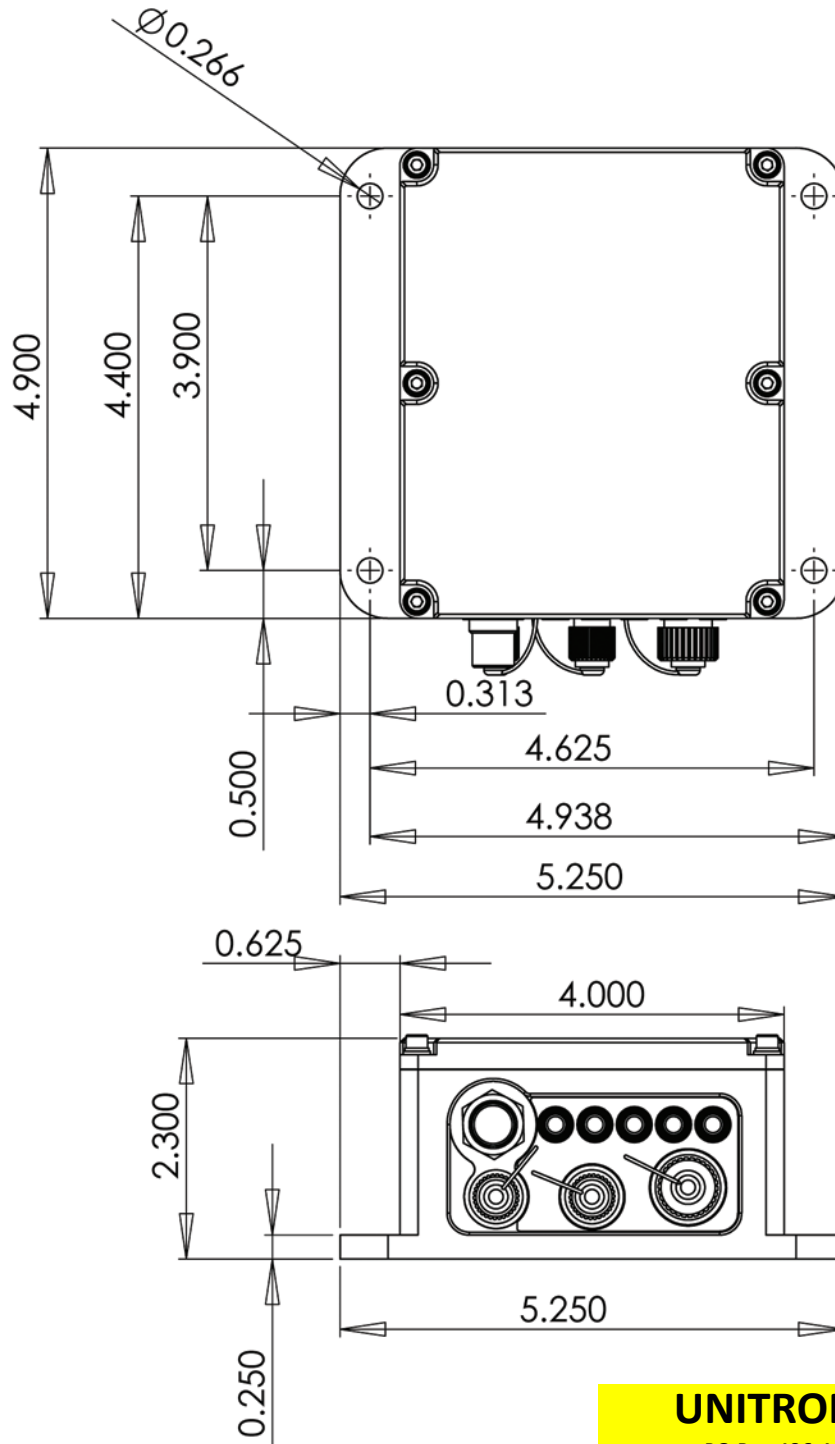

UNITRONIX Pty Ltd

PO Box 486, Morisset NSW 2264

NSW: Tel: 61 2 4977 3511 Fax: 61 2 4977 3522

WA: Tel: 61 8 9455 2424 Fax: 61 8 9455 2458

unitsyd@unitronix.com.au www.unitronix.com.au