

## Intel® Core™ 2 Duo Processor, Dual PMC, Rugged Conduction-Cooled



### APPLICATIONS

The PP 452/03x-RC is a PC-compatible, high functionality, dual PMC, single XMC (PCI Express™ Mezzanine Card), ruggedized conduction-cooled CompactPCI® board supporting the Intel® Core™ 2 Duo processor and the Intel® E7520 server class chipset. The processor contains two CPU cores and shared L2 cache. The PP 452/03x features 4 Gbytes DDR2 ECC SDRAM and a variety of I/O interfaces. The PP 452/03x-RC will operate in a system slot, a peripheral slot or independently from the CompactPCI bus. The board supports two Gigabit

Ethernet ports, and is compliant with the PICMG® 2.16 specification. Full system monitoring is provided by the PICMG 2.9 compliant IPMI interface. The PP 452/03x-RC, as a ruggedized conduction-cooled board, is suitable for a range of demanding applications within the defense, industrial control, telemetry, transportation, and aerospace markets. To simplify the board's integration many popular standard operating systems are supported. This board is rear I/O plug compatible with the PP 452/03x and PP 452/03x-RA families.

### HIGHLIGHTS

- Ruggedized 6U single board computer:
  - conduction-cooled to IEEE 1101.2
  - supports 2 conduction-cooled PMC modules conforming to ANSI/VITA 20
  - -40°C to +85°C operating temperature, designed to VITA 47 Class C4
  - conformally coated
- 1.5 GHz Intel® Core™ 2 Duo processor:
  - 667 MHz Front Side Bus
  - 4 Mbytes L2 cache
  - Intel® 64 Technology (64-bit computing support)
- 4 Gbytes of dual channel DDR2-400 ECC SDRAM
- 1 x PMC/XMC site and 1 x PMC site, both with rear user I/O:
  - both PMC sites support 32/64-bit; 33/66MHz PCI-X
  - XMC site supports up to x8 PCI Express™
- 2 x SATA150 interfaces via rear
- EIDE onboard mass storage interfaces:
  - onboard soldered Flash drive
  - option for removable Flash drive
  - option for removable CompactFlash® carrier
- 3 x Universal Serial Bus (USB 2.0), 1 x RS232 interfaces
- 2 x 10/100/1000Mbps Ethernet interfaces:
  - Dual Gigabit Packet Switching Backplane (PICMG 2.16)
- Watchdog timer and Long Duration Timer
- CompactPCI controller:
  - operates in system slot or peripheral slot
  - 32/64-bit at 33/66 MHz CompactPCI interface
- Option to bypass CompactPCI bus (Satellite Mode)
- IPMI (Intelligent Platform Management Interface)
- PICMG 2.9 (System Management Specification)
- Single slot (for all option combinations)
- Non-ruggedized air-cooled versions available:
  - see PP 452/03x datasheet
  - rear plug compatible with ruggedized versions
  - useful for bench development
  - use in commercial (non-rugged) applications
- Ruggedized air-cooled version (RA-Series) planned:
  - see PP 452/03x-RA datasheet
  - -40°C to +75°C, conformally coated
- Support for Linux®, Windows® XP, Windows® XP Embedded, Windows® Server 2003, Windows® 2000, QNX®, Solaris™ and VxWorks®

## Ruggedized dual PMC/XMC controller

- conduction-cooled to IEEE 1101.2
- supports 2 x conduction-cooled PMC/XMC modules conforming to ANSI/VITA 20
- conformally coated

## Central Processor

- Intel® dual-core processor
- 1.5 GHz Intel® Core™ 2 Duo processor L7400:-
  - 4 Mbytes of secondary (L2) on-die cache
  - 667 MHz Front Side Bus
- Intel® 64 Technology (64-bit computing)
- uses µFC-BGA 478 (micro Flip-Chip Ball Grid Array) package
- utilizes Intel® E7520 server class chipset:-
  - uses Intel® 6300ESB I/O Controller Hub
- provision for XDP debug port

## SDRAM

- supports 4 Gbytes DDR2-400 ECC SDRAM:-
  - 4 Gbytes soldered on-board
  - up to four bit error correction
  - peak bandwidth of 6.4 Gbytes/s
  - dual channel architecture
- accessible from processor and CompactPCI bus

## Mass Storage Interfaces

- 2 x SATA-150 interfaces via J5
- on-board EIDE interfaces:-
  - 4 Gbytes on-board soldered Flash disk
  - option for 4 Gbytes Flash Disk Module
  - option for ruggedized CompactFlash™ carrier (uses PMC site)

## Ethernet Interfaces

- 2 x rear interfaces implemented by Intel® 82574L controllers via x1 PCI Express™ links:-
  - support for PICMG 2.16 R1.0 - Packet Switching Backplane (PSB)
- supports 10 Base-T, 100 Base-TX, 1000 Base-T

## PMC/XMC Interfaces

- 1 x PMC/XMC site and 1 x PMC site
- common features for both PMC sites:-
  - 32/64-bit, 33/66 MHz PCI/PCI-X operation
  - 3.3V or 5V PCI signaling levels
  - PMC connectors used for rear I/O
- XMC (PCI Express™ Mezzanine Card) site interface supported via x8 PCI Express link

## Serial Interface

- 1 x RS232 serial channels:-
  - Tx, Rx, RI, CTS, RTS, DSR, DTR and DCD signals via J5
- 16550 compatible UART

## Other Peripheral Interfaces

- PC Real Time Clock (Year 2000 compliant)
- watchdog timer
- 1 x 32-bit Long Duration Timer with processor interrupt capability
- system fan monitor; CPU temperature monitor; voltages monitor:-
  - accessible via IPMI
- 5 GPIO signals accessed via J5
- 3 x USB 2.0 interfaces accessed via J5
- independent legacy speaker output via J3

## Flash EPROM

- 1 Mbyte of BIOS Flash EPROM - 8-bits wide

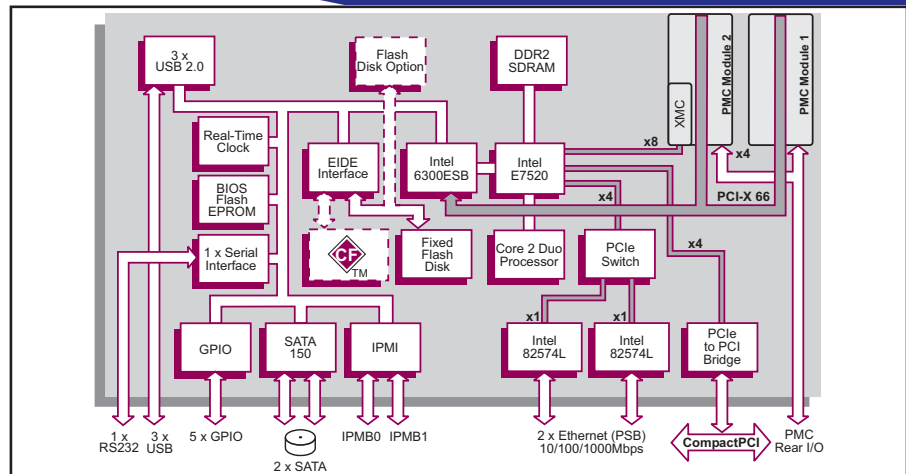

## Firmware Support

- Phoenix® Server BIOS
- comprehensive Power-On Self-Test (POST)
- LAN boot firmware included

## Software Support

- support for Linux®, Windows® XP, Windows® XP Embedded, Windows® Server 2003, Windows® 2000, QNX®, Solaris™ and VxWorks®

## CompactPCI Interface

- compliant with PICMG 2.0 R3.0; 3.3V or 5V signaling levels (universal signaling support)
- 33/66 MHz, 32/64-bit interface accessed via J1/J2 connectors
- PCI Express to PCI bridge for off-board accesses
- J4 connector not fitted
- PICMG 2.1 R2.0 Hot Swap compliant
- operates as a System Slot controller or in a Peripheral slot
- option to disable CompactPCI interface (Satellite Mode):-
  - receives power from CompactPCI bus
  - board can be hot swapped

## IPMI

- PICMG 2.9 R1.0 (System Management Specification):-
  - implements the IPMB0 interface
  - implements an IPMB1 interface
- on-board Baseboard Management Controller
- supports 8 Kbytes of non-volatile memory

## Electrical Specification

- +5V@3.1A (typical at 1.5 GHz with 4 Gbytes DRAM); +5% / -3%
- +3.3V@5.5A; +5% / -3%
- +12V@0.01A; -12V@0.01A
- +12V and -12V routed to PMC slots

## Safety

- PCB (PWB) manufactured with flammability rating of 94V-0

## Environmental Specification

- operating temperatures (VITA 47 Class CC4):-
  - -40°C to +85°C

- storage temperatures (VITA 47 Class C4)
  - -55°C to +105°C
- 5% to 95% Relative Humidity, non condensing (operating and storage)
- altitude (operating):
  - -1,000 to 50,000 feet (-305 to 15,240 metres)
- ruggedized and commercial air-cooled versions, see separate datasheets
  - rear plug compatible
  - commercial: PP 452/03x (available)
  - air-cooled: PP 452/03x-RA (planned)

## Mechanical Specification

- 6U form-factor: 9.2inches x 6.3inches (233mm x 160mm)
- single-slot: 0.8inches (20.3mm)
- connectors: IEC-1076-4-101 for J1-J5
- operating shock (VITA 47, conduction-cooled): 40g, 11ms, 1/2 sine
- operating random vibration (VITA 47 Class V3): PSD increasing at +3dB/octave (5Hz to 100Hz) PSD = 0.1 g<sup>2</sup>/Hz (100Hz to 1kHz) PSD decreasing at -6dB/octave (1kHz to 2kHz)

(PSD = Power Spectral Density)

## ORDERING INFORMATION

Order Number	Product Description (Hardware)
PP 452/031-xyRC	1.5 GHz Core 2 Duo Processor L7400 ruggedized conduction-cooled SBC

Replace the order number suffix (xy) with selections from the following:

where x =  
 1 - 3.3V PMC, Ethernet via rear panel  
 2 - 3.3V PMC, Ethernet via PICMG 2.16  
 3 - 5V PMC, Ethernet via rear panel  
 4 - 5V PMC, Ethernet via PICMG 2.16

where y = memory size  
 2 - reserved  
 3 - 4 Gbytes

AD 200/002-10RC	Ruggedized Dual CompactFlash Carrier
AD 230/001-04RC	Ruggedized EIDE 4Gbytes Flash Disk Module