

Intel® Core™ 2 Duo Processor, 3U SBC, Rugged Conduction-Cooled



APPLICATIONS

The TP 402/35x-RC is a PC-compatible high performance, high functionality, ruggedized 3U CompactPCI® board supporting the Intel® Core™ 2 Duo processor, 1.5 GHz or 1.06 GHz. It utilizes the Intel 3100 embedded server chipset to support up to 4 Gbytes of soldered DDR2 ECC SDRAM. This single slot board features a XMC site and a variety of interfaces including dual Serial ATA150, dual Gigabit Ethernet, RS232/422 and USB. The TP 402/35x-RC is a ruggedized conduction-cooled board

operating in temperatures ranging from -40°C to +85°C, where it is suitable for a range of demanding applications within the defense, industrial control, telecomms, telemetry, transportation, scientific and aerospace markets. Ruggedized or non-ruggedized air-cooled versions are also available. To simplify the board's integration many popular industry standard operating systems are supported.

HIGHLIGHTS

- Ruggedized 3U single board computer:
 - conduction-cooled to ANSI/VITA 30.1-2002
 - -40°C to +85°C operating temperature
 - conformally coated
- 1.06 GHz or 1.5 GHz Intel® Core™ 2 Duo processor:
 - 64 Kbytes L1 cache
 - 4 Mbytes L2 cache
 - Intel® 64 Technology (64-bit computing support)
 - low power processor
- 2 or 4 Gbytes of soldered DDR2-400 registered ECC SDRAM
- XMC module interface with rear I/O:
 - XMC module interface (x4 PCI Express®)
- 2 x 10/100/1000Mbps Ethernet interfaces accessed via J2
- 5 x Serial ATA150 channels:
 - 2 x channels accessed via J2
 - 1 x channel for on-board Flash disk
 - 2 x channels routed to optional Flash Disk Module
- 2 serial channel interfaces accessed via J2
- 2 x USB 2.0 interfaces accessed via J2
- Watchdog and long duration timer
- CompactPCI controller:
 - operates in the system slot or in a peripheral slot
 - 32-bit at 33/66 MHz CompactPCI interface
- Option to bypass CompactPCI bus (Satellite Mode)
- Option for graphics on separate PMC card:
 - graphics PMC mounted on single slot 3U PMC carrier
 - analog and digital graphics via PMC rear I/O
 - ruggedized or non-ruggedized versions
- Ruggedized air-cooled version (RA-Series):
 - -40°C to +75°C
 - conformally coated
 - see separate TP 402/35x-RA datasheet
- Non-ruggedized air-cooled versions:
 - rear plug compatible with the ruggedized version
 - useful for bench development
 - use in commercial (non-rugged) applications
 - see separate TP 402/35x datasheet
- Support for Linux®, Windows® XP, Windows® XP Embedded, Windows® Server 2003, Windows® 2000, QNX®, LynxOS® and VxWorks®

Ruggedized Single Board Computer

- conduction-cooled to ANSI/VITA 30.1-2002
- conformally coated
- air-cooled versions available

Central Processor

- 1.06 GHz Intel Core 2 Duo Processor U7500 or 1.5 GHz Intel® Core™ 2 Duo processor L7400:-
 - using a FC-BGA 478 (micro Flip-Chip Ball Grid Array) package
 - 64 Kbytes of primary (L1) on-die cache
 - 4 Mbytes of shared secondary (L2) on-die cache
 - 667 MHz Front Side Bus (FSB)
 - Intel® 64 Technology (64-bit computing support)
- utilizes 64-bit Intel® 3100 server chipset:-
 - single chip chipset with integrated memory and I/O controllers
- provision for ITP debug port

DRAM

- 2 or 4 Gbytes soldered DDR2-400 registered ECC SDRAM using:-
 - single channel memory
 - single-bit error correction
 - peak bandwidth of up to 3.2 Gbytes/s
- accessible from processor or CompactPCI® bus

Hard/Flash Disk Interfaces

- 5 x Serial ATA150 interfaces:-
 - transfer rate up to 150 Mbytes/s
- 2 x channels accessible via J2
- 1 x channel routed to on-board 512 Mbytes Flash disk
- 2 x channels routed to optional Flash Disk Module:-
 - one or two Flash disk drives
 - appear as one or two hard disk drives
 - uses XMC site

Ethernet Interfaces

- 2 x channels supporting:-
 - 10 Base-T, 100 Base-TX, 1000 Base-T
 - implemented by Intel® 82571EB via x4 PCI Express® port
 - both channels accessed via J2

XMC Interface

- 1 x XMC site, all in a single 4HP slot:-
 - XMC (Switched Mezzanine Card) interface supported via x4 PCI Express port
 - rear panel I/O via J2
 - not available with Flash Disk Module fitted

Optional Graphics Interface

- optional ruggedized PMC card mounted on ruggedized 3U CompactPCI PMC carrier:-
 - see separate IO PMC/722-RC and TP CRx/PMC-RC datasheets
- for IO PMC/722-RC:-
 - implemented by Silicon Motion SM722
 - analog and digital graphics accessed via PMC rear I/O
 - 8 Mbytes video memory
 - resolutions up to 1280 x 1024; supporting up to 16M colors

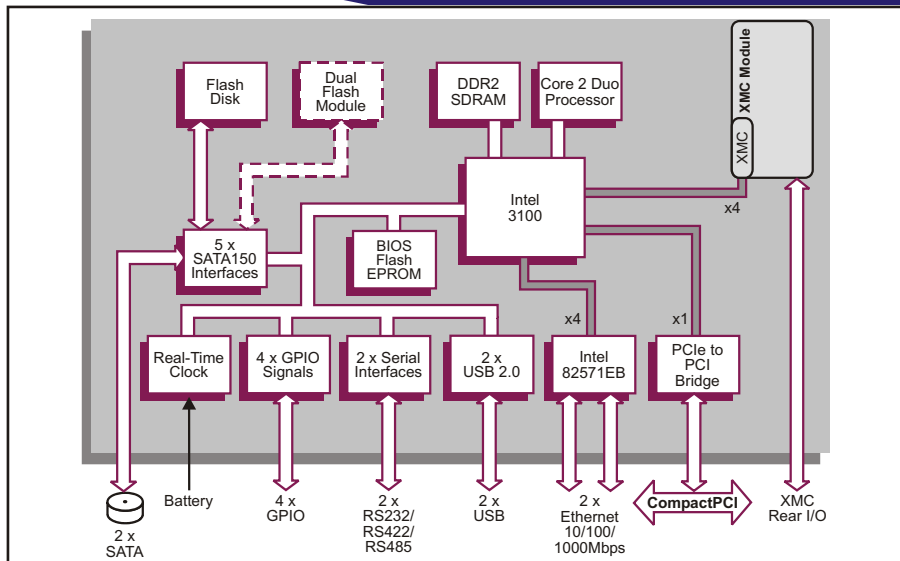

Serial Interfaces

- 2 serial interfaces accessible via J2
- 1 x RS232 interface supporting Tx and Rx
- 1 x RS232 interface supporting Tx, Rx, RI, CTS, RTS, DSR, DTR and DCD or 1 x RS422/485 supporting Tx and Rx
- 16550 compatible UARTs

Flash EPROM

- 1 Mbyte of BIOS Flash EPROM
- hardware write protect provided

Other Peripheral Interfaces

- PC-compatible Real Time Clock (Year 2000 compliant)
- long duration timer
- watchdog timer
- legacy speaker interface
- 2 x USB 2.0 interfaces:-
 - both accessed via J2
- external battery supply for RTC and BIOS data
- 4 x GPIO signals via J2
- on-board I²C bus used for local temperature and power supply sensors, accessible via J1

CompactPCI Interface

- universal signaling support, compliant with PICMG 2.0 R3.0; 3.3V or 5V signaling levels
- 33/66 MHz; 32-bit interface accessed via J1
- utilizing a PCI Express-PCI bridge for off-board accesses
- operates as a System Slot controller (supporting up to 7 Peripheral Slots) or operates in a Peripheral Slot:-
 - supports hot-swapping peripheral boards
 - PICMG 2.1 R2.0 Hot Swap Specification
- option to disable CompactPCI interface (Satellite Mode):-
 - receives power from CompactPCI bus
 - board can be hot swapped

Firmware Support

- Phoenix™ TrustedCore BIOS
- Trusted Platform Module (TPM) support
- comprehensive Power-On Self-Test (POST)
- LAN boot firmware included

Software Support

- supports Linux®, Windows® XP, Windows® XP Embedded, Windows® 2000, Windows® Server 2003, QNX®, LynxOS® and VxWorks®

Electrical Specification

- +5V@3.1A (typical at 1.5 GHz, 1Gbyte DRAM)
- +3.3V@3.7A (typical with 1Gbyte DRAM)
- voltages +5%/-3%
- +12V and -12V not required

Safety

- PCB (PWB) manufactured with flammability rating of 94V-0

Environmental Specification

- operating temperature:-
 - VITA 47 Class CC4, -40°C to +85°C
 - conduction-cooled
- storage temperature:-
 - VITA 47 Class C4, -55°C to +105°C
- operating altitude:-
 - -1,000 to 50,000 feet (-305 to 15,240 meters)
- 5% to 95% Relative Humidity, non condensing (operating/storage)
- air-cooled versions:-
 - rear plug compatible
 - ruggedized: see TP 402/35x-RA datasheet
 - commercial: see TP 402/35x datasheet

Mechanical Specification

- 3U form-factor:
 - 3.9-inches x 6.3-inches (100mm x 160mm)
- single slot
- connectors: IEC-1076-4-101 for J1-J2
- operating mechanical:-
 - shock - VITA 47 Class OS2, 40g
- random vibration - VITA 47 Class V3, 0.1g²/Hz

ORDERING INFORMATION

Order Number Product Description (Hardware)

TP 402/350-1yRC 1.06 GHz Core 2 Duo Processor U7500
 TP 402/351-1yRC 1.5 GHz Core 2 Duo processor L7400

For the order number suffix (y) option please contact your local sales office: where y = SDRAM size

y - up to 4 Gbytes SDRAM

For accessories please contact your local sales office.
 For air-cooled versions: commercial, extended temperature or ruggedized please contact your local sales office.